

**Rugged
Ridge**



OMIX-ADA, Inc.



460 HORIZON DR. SUITE 400 | SUWANEE, GA 30024 | PHONE: 770-614-6101 | FAX: 770-614-6069 | info@omix-ada.com

11030.01
11030.10

Rugged Ridge® X-Clamp PATENT PENDING

Contents:

- A- X-Clamp Front
- B- X-Clamp Back
- C- Mount Tab
- D- Short Cap Screw
- E- Medium Cap Screw
- F- Long Cap Screw
- G- Flat Head Screw
- H- Jam Nut
- I- Rugged Ridge Logo

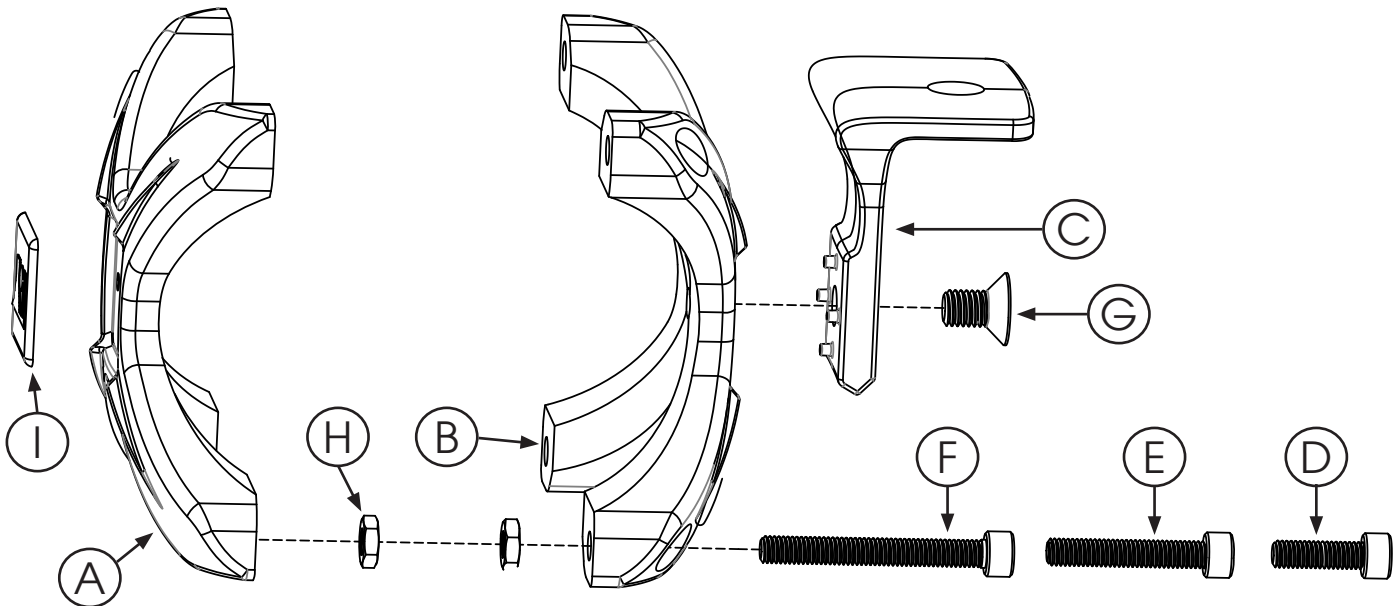
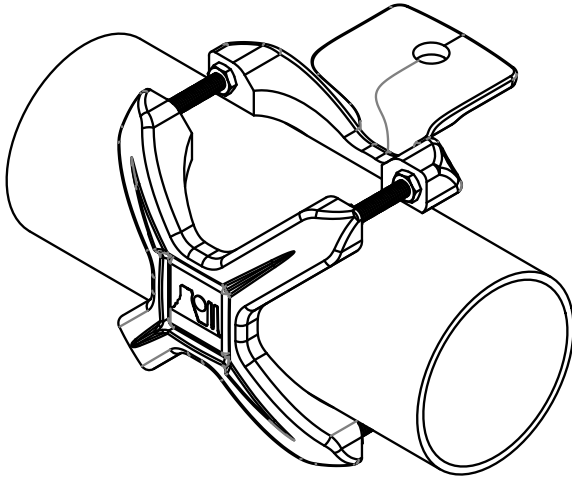

Pivotal Fit Technology Explained

The X-Clamp from Rugged Ridge® features an innovative and unique adjustment which allows mounting to tubes ranging from 2"-3" in diameter. Rotate the X-Clamp to fit your tube, and pivot the mounting bracket to the desired position.

OMIX-ADA® TECHNICAL SUPPORT

PHONE: M-F 8am - 5pm EST 1-800-449-6649 | EMAIL: techsupport@omix-ada.com

FOR WARRANTY INFORMATION VISIT: www.Omix-Ada.com



OMIX-ADA, Inc.

460 HORIZON DR. SUITE 400 | SUWANEE, GA 30024 | PHONE: 770-614-6101 | FAX: 770-614-6069 | info@omix-ada.com

11030.01
11030.10

Rugged Ridge® X-Clamp PATENT PENDING

1. Disassemble the X-Clamp Front and X-Clamp Back by loosening the jam nuts then removing the 4 bolts and 8 jam nuts.
2. Determine the correct orientation to mount the X-Clamp by holding the X-Clamp Front and X-Clamp Back to the tube. Rotate the X-Clamp pieces 90° to make sure you have the correct orientation.

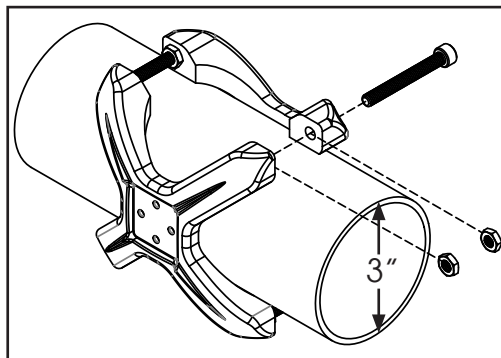
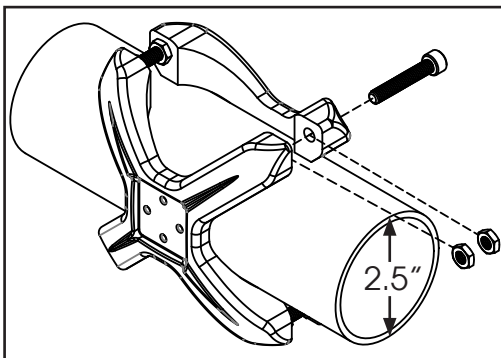
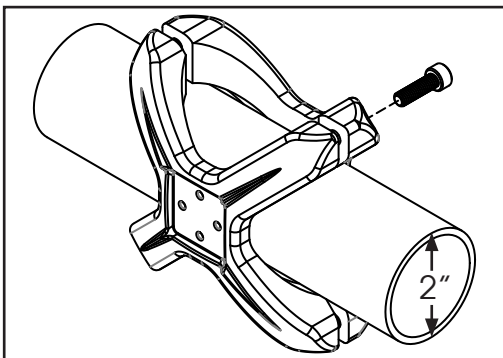

3. Select appropriate bolt length for your tube diameter. 2.5" and 3" diameter tubes require jam nuts. Note: to prevent jam nut interference with the high point of tube, keep jam nuts separate on bolt shaft during install.

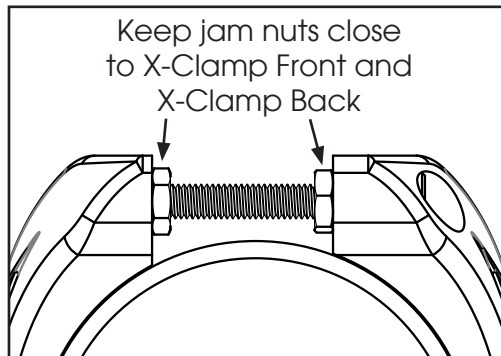

4. Attach X-Clamp to tube by gradually tightening all bolts evenly in an "X" pattern. Tighten to 3 ft-lbs. Do not exceed 3 ft-lbs.

5. Tighten jam nuts to a snug fit. Do not over tighten. Make sure bolts are tightened before tightening jam nuts.

6. Attach mounting tab to X-Clamp Back. Tighten to 8 ft-lbs.

NOTICE Apply red Loctite(R) or equivalent thread sealer before tightening threads of flat head screw.

7. Apply logo to recess in X-Clamp Front.

WARNING Inspect and retorque fasteners after first 50 miles and frequently thereafter, particularly after use off-road.

DO NOT USE & REPLACE IF X-CLAMP OR FASTENERS BECOME DAMAGED.

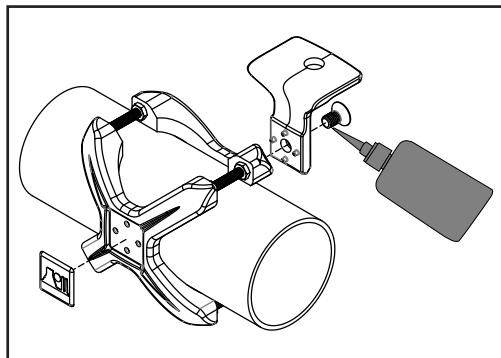

OMIX-ADA® TECHNICAL SUPPORT

PHONE: M-F 8am - 5pm EST 1-800-449-6649 | **EMAIL:** techsupport@omix-ada.com

FOR WARRANTY INFORMATION VISIT: www.Omix-Ada.com