



RHINO-RACK

Aerodynamic & Heavy Duty Roof Rack Systems

RLTFMS Rhino Heavy Duty - Two, Three and Four Cross Bar System, MERCEDES Sprinter SWB/LWB, VW Crafter MWB/LWB.

Important: Please read these instructions carefully prior to installation.
Please refer to your fitting instruction to ensure that the roof racks are installed in the correct locations.
Check the contents of kit before commencing fitment and report any discrepancies.
Place these instructions in the vehicle's glove box after installation is complete.

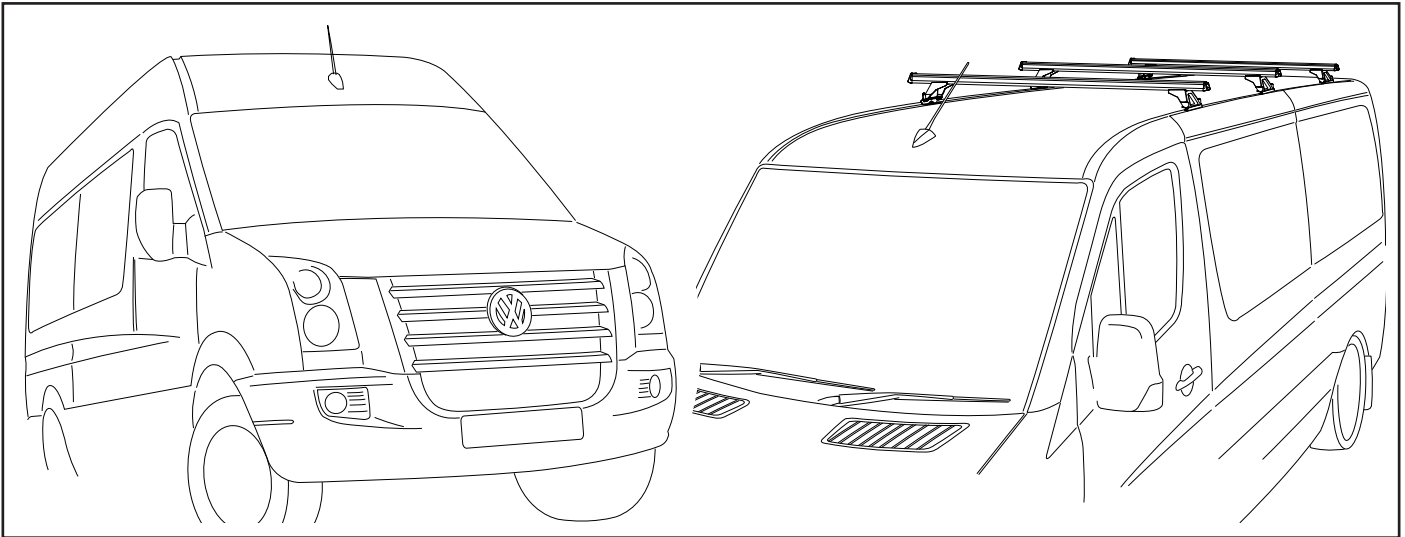

Care Instruction: Wash vehicle roof especially the mounting points prior to installation.

Important Information

Maximum carrying capacity: 100kg

Recommendations:

It is essential that all bolt connections be checked after driving a short distance when you first install your cross bars. Bolt connections should be checked again at regular intervals (probably once a week is enough, depending on road conditions, usage, loads and distances travelled). You should also check the cross bars each time they are re-fitted.

Make sure to fasten your load securely. Please ensure that all loads are evenly distributed and that the centre of gravity is kept as low as possible.

Use only non-stretch fastening ropes or straps.

Sensitivity to cross winds, behaviour in curves and braking.

The handling characteristics of the vehicle, changes when you transport a load on the roof. For safety reasons, we recommend you exercise extreme care when transporting wind-resisting loads; special consideration must be taken into account when braking.

Please remove cross bars when putting vehicle through an automatic car wash.

Load Ratings:

Maximum permissible load is 100kg per pair of cross bars (include the weight of the cross bars, 5kg). When cross bars are to be used in off-road conditions, please build a safety factor of 1.5 into this load limit. Although the cross bars are tested and approved to AS1235-2000, Australian road conditions can be much more rigorous. However, increasing the number of cross bars does not increase the vehicles maximum permissible roof loading.

Note for Dealers and Fitters:

It is your responsibility to ensure instructions are given to the end user or client.

Rhino-Rack
3 Pike Street, Rydalmere,
NSW 2116, Australia.
(Ph) (02) 9638 4744
(Fax) (02) 9638 4822

Document No: RR-148
Prepared By: Craig Jones
Authorised By: Gary England

Issue No: 02
Issue Date: 13/06/2007

These instructions remain the property of Fetovu Pty Ltd T/as Rhino-Rack and may not be used or changed for any other purpose than intended.



RLTFMS - MERCEDES Sprinter SWB/LWB, VW Crafter MWB/LWB.

Parts List

Item	Component Name	Qty	Part No.
1	Heavy Duty Rubber Buffer 1800mm	2-4	
2	Heavy Duty Crossbar 1800mm	2-4	
3	Heavy Duty Crossbar End Cap	4-8	M002
4	M10 Channel Nut	4-8	N024
5	RLTF Heavy Duty Leg	4-8	M010
6	M6 x 35mm Security Screw	8-16	B092
7	M6 Spring Washer	8-16	W004
8	M6 x 12.5mm Flat Washer	8-16	W003
9	M10 x 38mm Flat Washer	4-8	W022
10	M10 Internal Shakeproof Washer	4-8	W021
11	M10 x 25mm Hex Bolt	4-8	B071
12	Mercedes/VW Bracket	4-8	C524
13	M8 Nyloc Nut	4-8	N028
14	M8 x 18 Flat Washer	8-16	W030
15	Foam Gasket Washer	4-8	C372
16	M8 x 20 Button Head Screw	4-8	B155
17	5mm Security Allen Key	1	H021
18	Fitting Instruction	1	RR-148

Tools Required:

- 5mm Security Allen key, provided in kit.
- 16mm or 5/8" spanner.
- Rubber mallet.
- Tape Measure.
- Silastic Sealant.

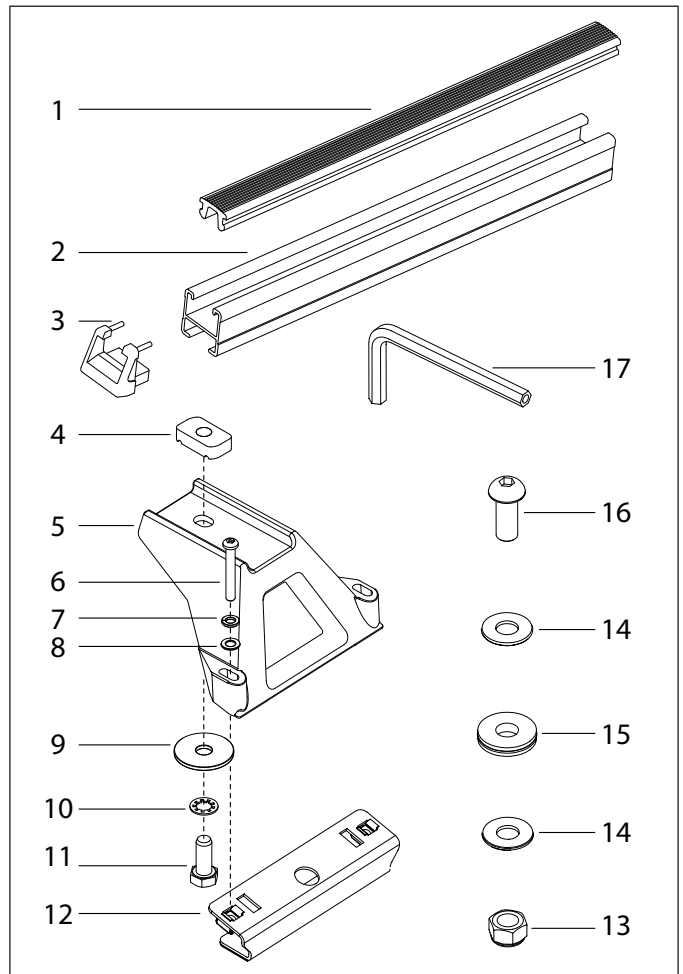

1

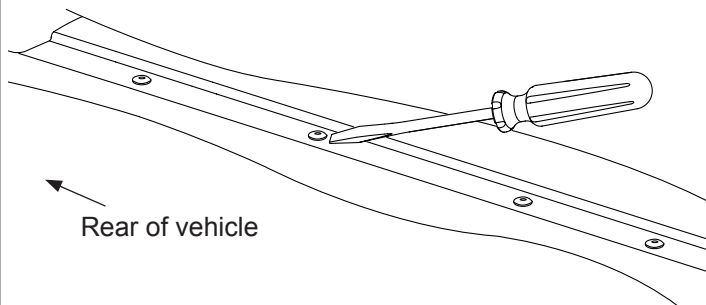

Plastic plugs in the roof channel need to be removed in order to fit the brackets. Only remove plugs from holes that you are going to use. Use a flat head screwdriver from the top to help lever the plugs out or push the plugs out from inside the vehicle. To eliminate rust, be careful not to scratch the paint work.

2

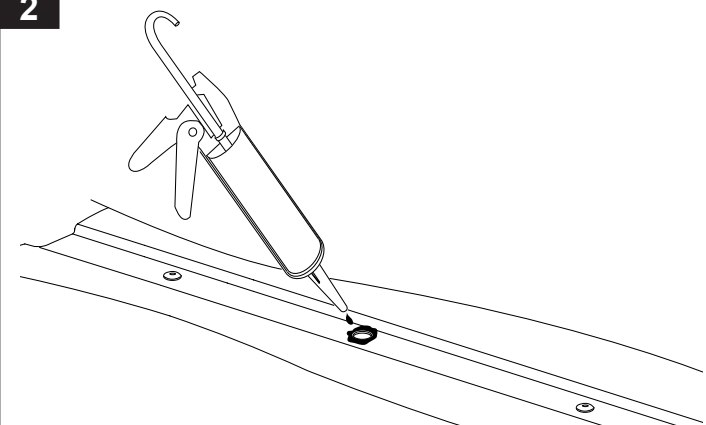

Apply silastic sealant in and around the holes you have removed the plugs from to eliminate water leaks.



RLTFMS - MERCEDES Sprinter SWB/LWB, VW Crafter MWB/LWB.

3 Place the bracket over the hole. Have the opening of the bracket facing the inside of the vehicle. Refer to diagram below for washer and nut placement. **Tighten M8 bolt to 5-6N/m.**

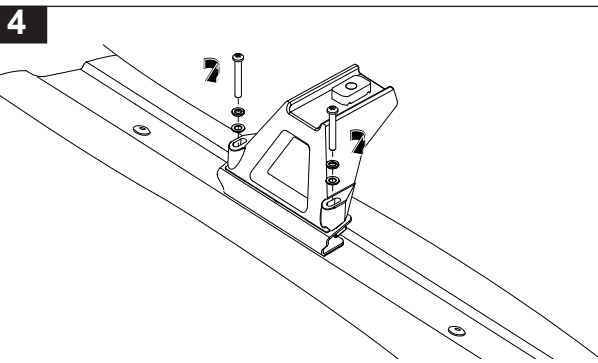
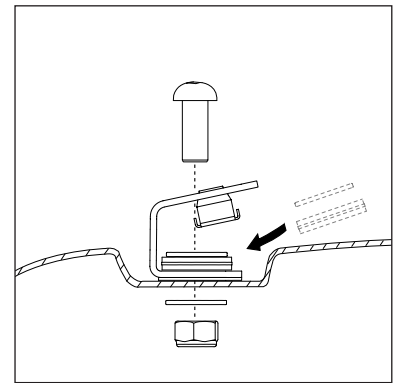
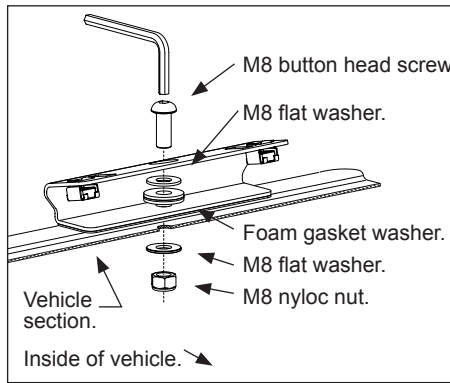
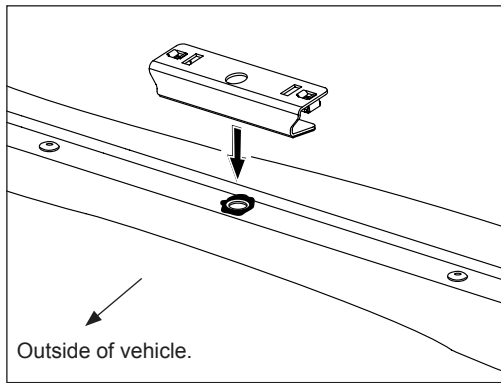

Finger tighten the support leg attachment bolts, as final adjustment and tightening occurs later.

5 Place the cross bar onto the support legs. Push the cross bar attachment bolt up and turn the bolt so that the channel nut is located fully across the cross bar. **Finger tighten the M10 cross bar attachment bolts.**

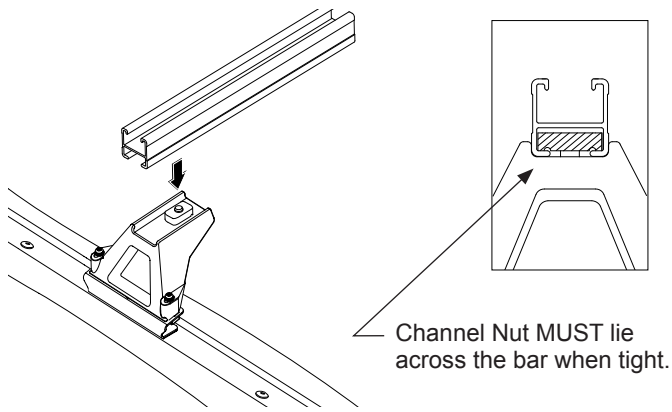

6 On all legs tighten the two M6 Security screws to 3-4Nm. **DO NOT OVER TIGHTEN.**

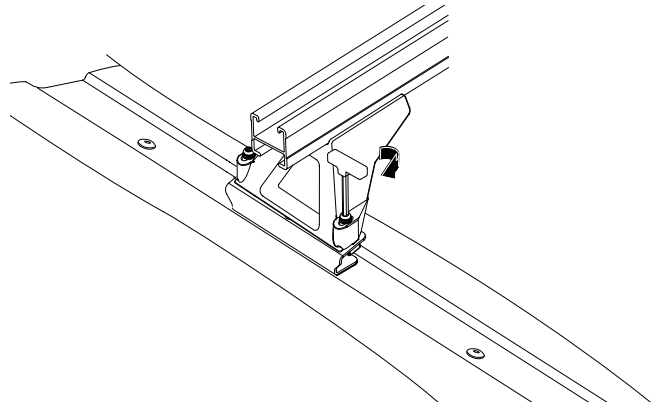

7 Ensure the cross bar overhang (A) is equal on both sides, re-adjust if required. Tighten all cross bar attachment bolts to 4-5N/m. **DO NOT OVER TIGHTEN.**

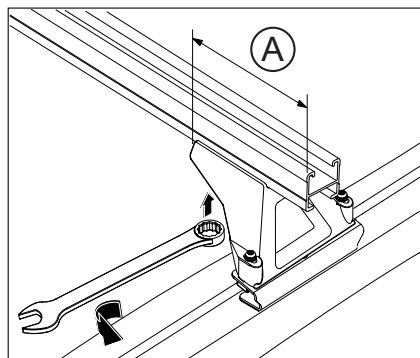

8 Insert the cross bar buffer strip into the top of the cross bar, check that the rubber is fully inserted, then fit the end caps into the cross bar ends, a rubber mallet maybe required to fit the end caps.

