



BESTOP

Half Door Installation Instructions

For: CJ5 (1955-1975), CJ6 (All), M38-A1 (1955-1971) Part Number: 53025

Congratulations on your purchasing decision. Bestop designed these Doors to give you years of dependability and performance with proper care. If you encounter any problems during the installation of your Doors, or at any later date, please contact your authorized Bestop dealer or call our Consumer Response Department, Monday - Friday, 8AM - 4:30PM (MST) at 1-800-346-3910 or (303) 465-1755 in Colorado.

WARNING

This product is designed primarily to enhance the appearance of the vehicle and to shield the occupants from ordinary weather conditions. Do not rely in any way on the components of this product to contain occupants within the vehicle, or to protect against injury or death in the event of an accident. This top will not protect the occupants from falling objects. Never operate vehicle in excess of manufacturer's specifications.

WEAR SEAT BELTS AT ALL TIMES

Read and follow, precisely, all installation instructions provided when installing top. Failure to do so may result in a poor fitting top and could place occupants of the vehicle in a potentially dangerous situation.

Installation Tips

Before you begin installing this door assembly, read all instructions thoroughly. Below are a few tips to make this installation easier.

For a smooth fit:

It is normal for fabric to contract and wrinkle when stored in the shipping carton. Within a few days after the installation, the fabric will relax and the wrinkles will disappear.

Parts List and Hardware Identification

Door, Lower - Right Qty - 1
 Door, Lower - Left Qty - 1

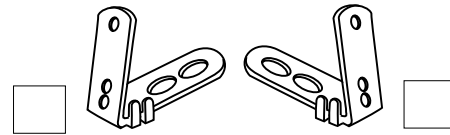

Vertical Mount -
 Left, Qty - 1, Part
 Number 207.30

Vertical Mount -
 Right, Qty - 1, Part
 Number 207.29

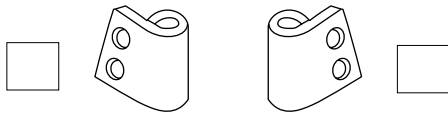

Upper Door Hinge -
 Left, Qty - 1,
 Part Number 1.37

Upper Door Hinge -
 Right, Qty - 1,
 Part Number 1.36

Door Striker - Right, Qty - 1,
 Part Number 212.87

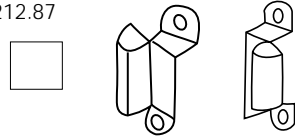

Door Striker - Left, Qty - 1,
 Part Number 212.88

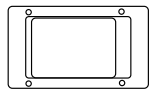

Paddle Handle
 Assembly, Qty - 2,
 Part Number 245.46

Tools Needed

7/32", 3/32", 3/16" Drill Bits
 Drill Motor
 Flat Screwdriver
 Center Punch
 7/16" Wrench
 Phillips Screwdriver
 Hammer

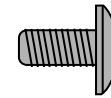

#10-24 Truss Head Machine Screw -
 Black, Qty - 12, Part Number 195.92



#10-24 Locknut, Qty - 12,
 Part Number 195.93



#6 x 3/8" Sheet Metal Screw,
 Qty - 12, Part Number 9.69

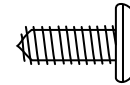

#14 x 1/2" Pan Head Screw,
 Qty - 4, Part Number 243.47

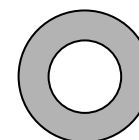

5/16" Black Washer,
 Qty - 4, Part Number
 233.04

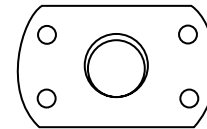

5/16-18 Tapping Plate, Qty - 4,
 Part Number 200.50

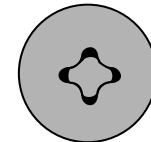
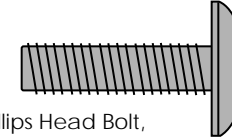

5/16-18 x 1" Phillips Head Bolt,
 Qty - 4, Part Number 236.20

Snap Stud, Qty - 12, Part
 Number 9.68

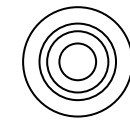

Step One

Insert the lower door pivot into the existing hole in the body. Slide the Upper Door Hinges over the upper door pivot. Hold the Upper Door Hinges against the body and use it as a template to mark the locations for the screws. Center punch and drill a 3/16" hole at each location. Install the hinge with two #14 x 1/2" Pan Head Screws. If necessary, bend the upper door pivot forward or backward a little at a time to form the frame to the contour of the body and to get a tight seal.

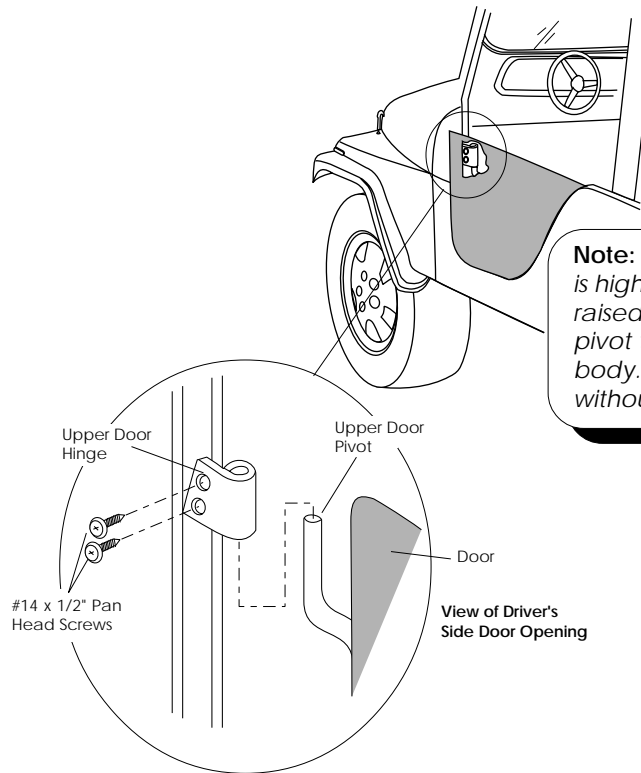

Note: Make sure that the Upper Door Hinge is high enough to allow the door to be raised up enough to allow the lower door pivot to be pulled out of the hole in the body. This will allow the door to be removed without taking off the Upper Door Hinge.

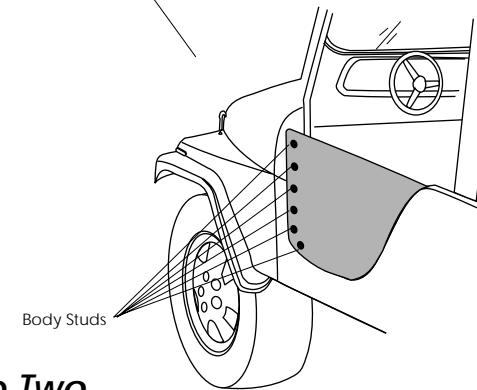
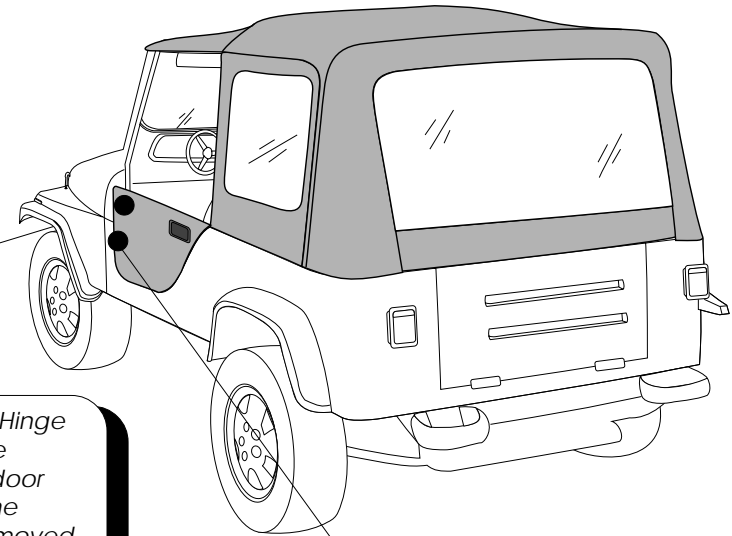

Step Two

Hold the door halfway open to install the Body Studs. Pull the fabric forward and mark the location for the top Body Stud. Drill a 3/32" hole and install a Body Stud with a #6 x 3/8" Sheet Metal Screw. Snap the fabric to the stud and repeat the process with the rest of the snaps on the door.

Warning:

The doors in this product are designed only for protection against the elements. Do not rely on the doors to contain occupants within the vehicle or to protect against injury during an accident. Door handles are only designed to aid in door closure. Door and handle will not support a person's weight.



53025 pg 3

Step Three

Locate the pre-cut "X" in the lower door panel where the Paddle Handle will fit into the mounting plate on the door frame. Fold the pre-cut fabric back and insert the Paddle Handle into the mounting plate so that the latch mechanism is inside of the vehicle and the latch bolt is toward the rear of the door. Align the four holes in the Paddle Handle Assembly with the four holes in the mounting plate. Use a pointed tool to punch four holes in the fabric to match the holes in the Paddle Handle and the mounting plate. Insert four #10-24 Truss Head Machine Screws from the outside and secure them with #10-24 Locknuts. Do not tighten the screws until all four are in place. Trim the excess fabric around the Paddle Handle. Repeat for both lower doors.

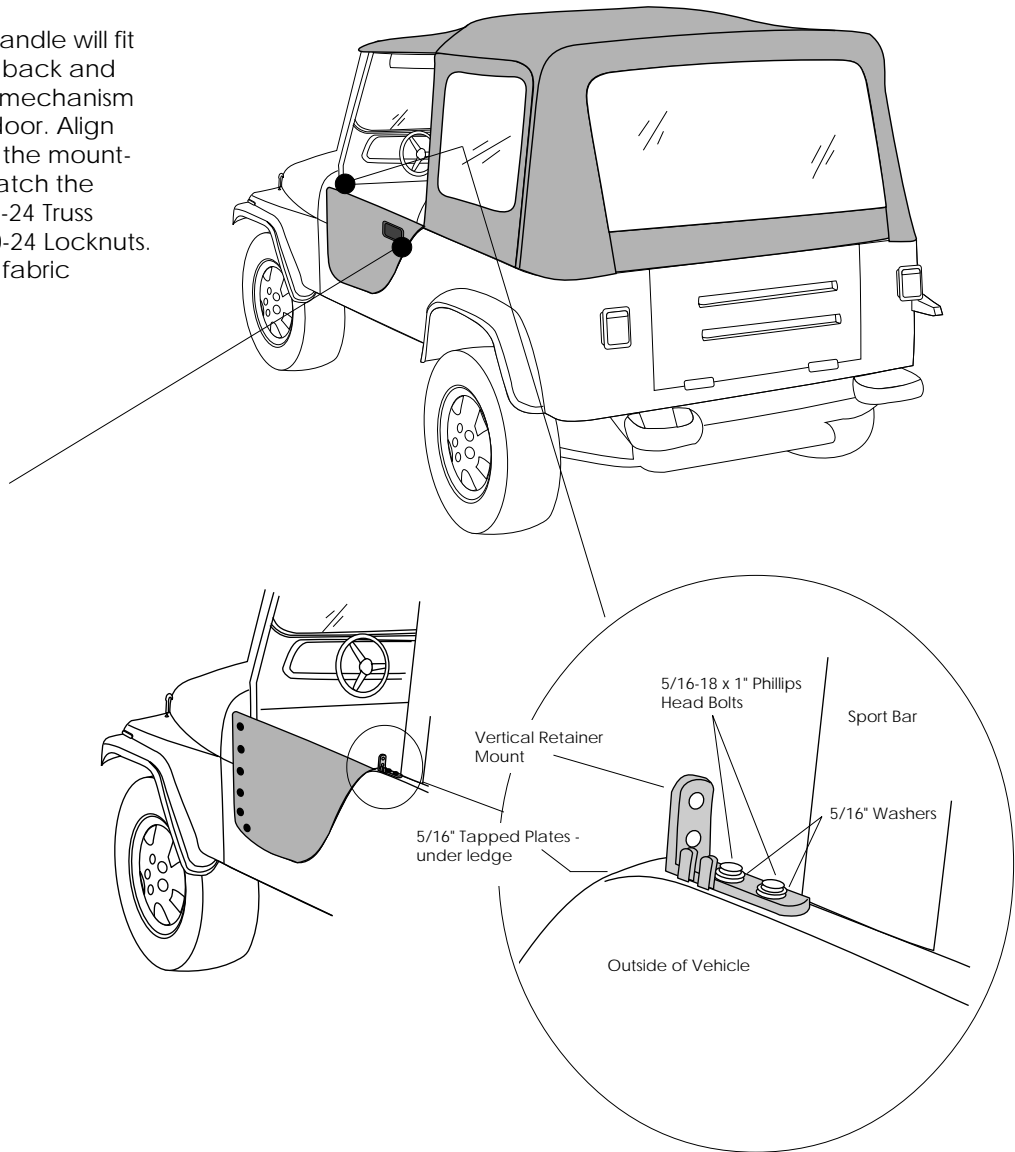
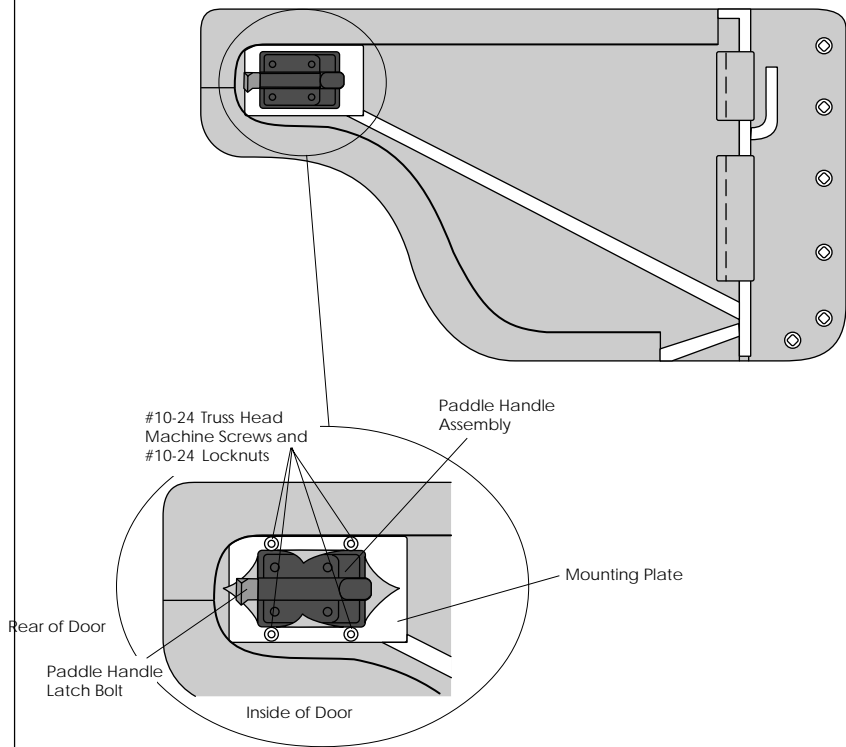

Step Four

Mount the Vertical Retainer Mounts on the vehicle, just behind the door openings. Install the mounts using two 5/16-18 x 1" Phillips Head Bolts, two 5/16" Washers and two 5/16" Tapped Plates.



Step Five

Close the door against the body and place the Door Striker behind the Paddle Handle Latch with the flat surface to the inside of the vehicle and with the raised end toward the top. Install the Door Striker on the Vertical Retainer Mount with two #10-24 Truss Head Machine Screws and two #10-24 Locknuts. The Door Striker may be adjusted in or out until you are satisfied with the way the door shuts and opens. Repeat on both sides of the vehicle.

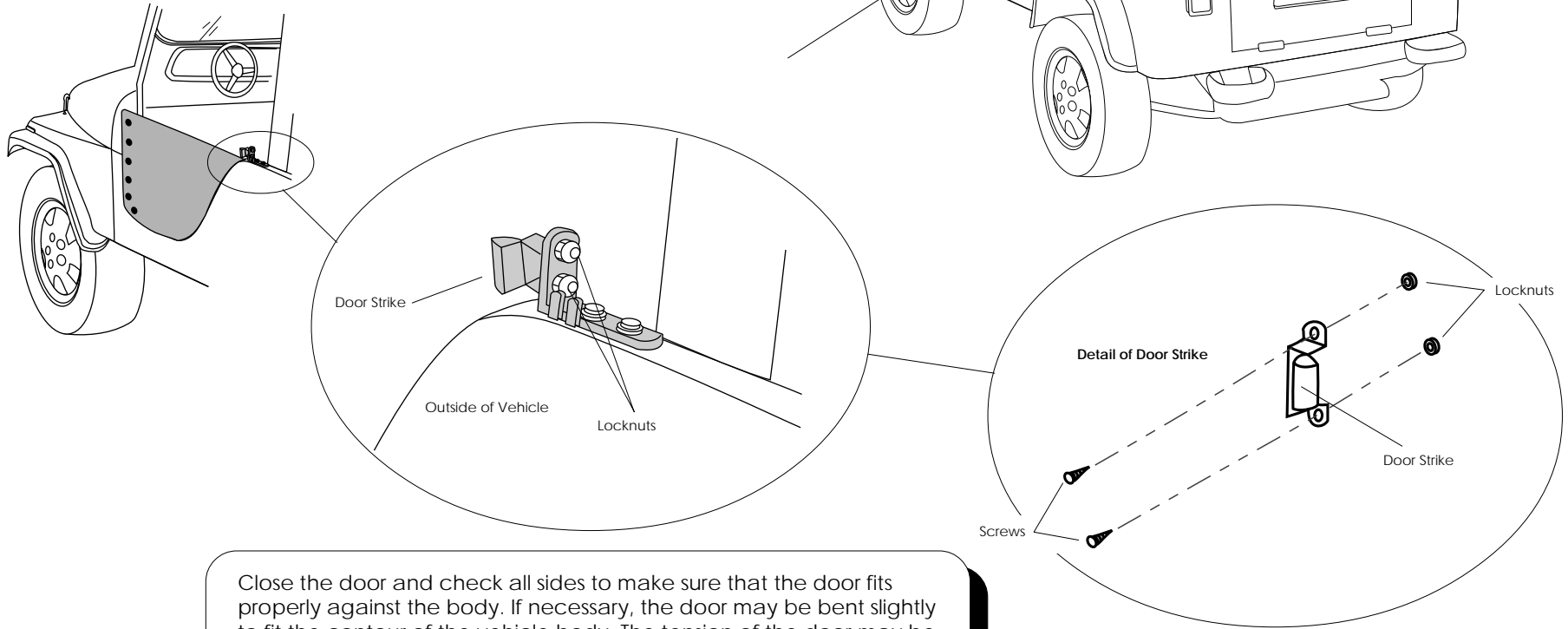

Close the door and check all sides to make sure that the door fits properly against the body. If necessary, the door may be bent slightly to fit the contour of the vehicle body. The tension of the door may be adjusted by adjusting the handle.

Care and Maintenance of your Bestop Top

Your top is made of the finest materials available. To keep it looking new and for the maximum possible wear, it will need periodic cleaning and maintenance.

Washing: The top fabric should be washed often using soap, warm water and a soft bristle brush. Rinse with clear water to remove all traces of soap.

Windows: Keep windows clean to avoid scratching. DO NOT use a brush on the windows! Wash with a watersoaked cloth or sponge and a mild dishwashing detergent. NEVER WIPE THE WINDOWS WHEN THEY ARE DRY. Be careful when cleaning snow or frost from the vinyl windows since they are easily scratched and may crack at low temperatures. DO NOT roll the sides or rear window in cold weather. The windows become stiff and will crack.

Zippers: Keeping the zipper cleaned and lubricated with a silicone lubricant will help prevent damage and keep the zippers in a smooth working condition. If a zipper opens behind the slider, the slider may have been spread apart. This problem can usually be repaired by using an ordinary pair of pliers to bring the sides back into parallel. Return slider to the end of the zipper in the normal Open position. Squeeze lightly at first and test the zipper. If the zipper continues to remain open squeeze more firmly with the pliers and try the zipper again. Repeat this procedure until the zipper operates correctly.

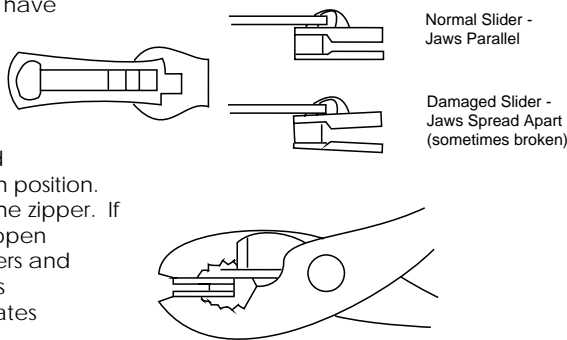

Water: Seeping through at the seams may be stopped by applying 3-M Scotchgard® on the inside of the seams. Rips in the fabric may be repaired with Bondex® iron on patches. Iron the patches to the Inside of the top, carefully following the Bondex® instructions.

Snaps: Keep snaps cleaned and lubricated with silicone to help prevent snaps from sticking to the studs. If a snap does become stuck to a stud, use a screwdriver and GENTLY pry apart to prevent permanent damage to the snap or the top fabric.

LIMITED WARRANTY

We warrant our product to be free from defects in material and workmanship, for the terms specified below, provided there has been normal use and proper maintenance. This warranty applies to the original purchaser only. All remedies under this warranty are limited to the repair or replacement of any item or items found by the factory to be defective within the time period specified.

If you have a warranty claim, first you must call our factory at the number below for instructions. You must retain proof of purchase and submit a copy with any items returned for warranty work. Upon completion of warranty work, if any, we will return the repaired or replaced item or items to you freight prepaid. Damage to our products caused by accidents, fire, vandalism, negligence, misinstallation, misuse, Acts of God, or by defective parts not manufactured by us, is not covered under this warranty.

THE WARRANTY TIME PERIOD IS AS FOLLOWS: ALL "SOFT GOODS" MANUFACTURED BY OUR COMPANY (USING PRIMARILY VINYL, PLASTICS, AND/OR FOAM): ONE YEAR FROM DATE OF PURCHASE.

ANY IMPLIED WARRANTIES OF MERCHANTABILITY AND/OR FITNESS FOR A PARTICULAR PURPOSE CREATED HEREBY ARE LIMITED IN DURATION TO THE SAME DURATION AND SCOPE AS THE EXPRESS WRITTEN WARRANTY. OUR COMPANY SHALL NOT BE LIABLE FOR ANY INCIDENTAL OR CONSEQUENTIAL DAMAGE.

Some states do not allow limitations on how long an implied warranty lasts, or the exclusion or limitation of incidental or consequential damages, so the above limitations or exclusions may not apply to you.

This warranty gives you specific legal rights, and you may also have other rights which vary from state to state.

For further information or request for warranty work, please contact:
Bestop Inc.
Customer Service
(800)346-3910
(303)465-1755

