



RHINO-RACK

Aerodynamic & Heavy Duty Roof Rack Systems

RLCP24 Rhino Heavy Duty Two Crossbar System Volkswagen Amarok

Important:

Please read these instructions prior to installation.
Check contents of kit before commencing fitment and report any discrepancies.
Place these instructions in vehicle's glovebox after installation is complete.

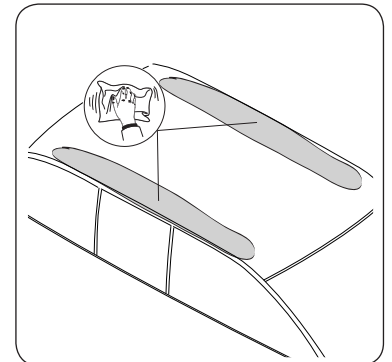
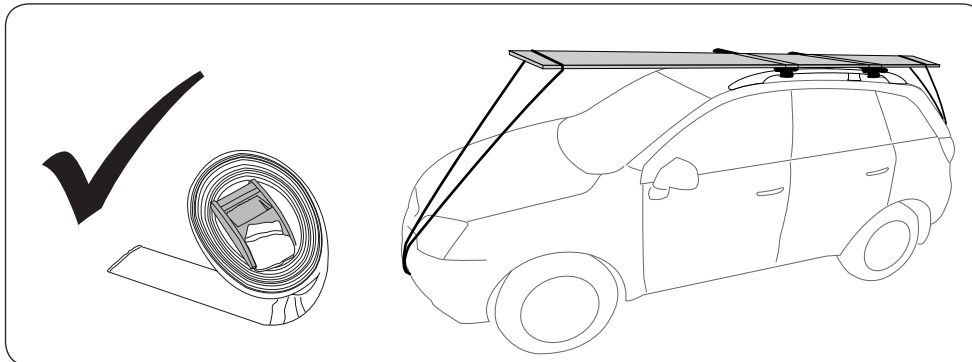
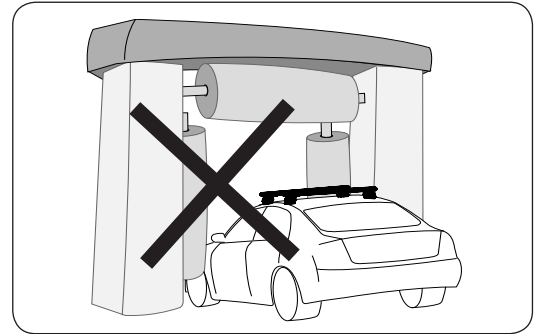
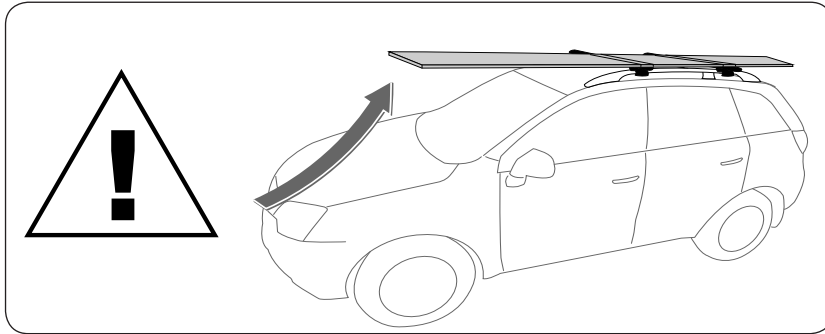

Maximum roof load: 100kg

Refer to vehicle manufacturers handbook for maximum roof loading. Always use lower of the two figures.

Recommendations:

It is essential that all bolt connections be checked after driving a short distance when you first install your crossbars. Bolt connections should be checked again at regular intervals (probably once a week is enough, depending on road conditions, usage, loads and distances travelled). You should also check the crossbars each time they are refitted. Make sure to fasten your load securely. Please ensure that all loads are evenly distributed and that the centre of gravity is kept as low as possible.

Crossbars must be removed when putting vehicle through an automatic car wash.

Carrying Loads: Use only non-stretch fastening ropes or straps to secure your load.

Caution: The handling characteristics of the vehicle change when you transport a load on the roof. For safety reasons we recommend you exercise extreme care when transporting wind-resistant loads. Special consideration must be taken into account when cornering and braking.

Load Ratings:

Maximum permissible load is 100kg (220lbs) for two crossbars including the weight of the crossbars, 5kg (11lbs). When crossbars are to be used in off-road conditions, please build a safety factor of 1.5 into this load limit for off-road use, two crossbars = **66kg (145lbs)**. Although the crossbars are tested and approved to AS1235-2000, off-road conditions can be much more rigorous. However, increasing the number of crossbars does not increase the vehicles maximum permissible roof loading.

Note for Dealers and Fitters:

It is your responsibility to ensure instructions are given to the end user or client.

Rhino-Rack
3 Pike Street, Rydalmere,
NSW 2116, Australia.
(Ph) (02) 9638 4744
(Fax) (02) 9638 4822

Document No: R106
Prepared By: Craig Jones
Authorised By: Chris Murty

Issue No: 01
Issue Date: 06/07/2011

These instructions remain the property of Rhino-Rack Australia Pty. Ltd. and may not be used or changed for any other purpose than intended.



RLCP24 - Volkswagen Amarok

Item	Component Name	Qty	Part No.
1	HD crossbar & rubber 1250mm	2	RB1250
2	RLCP leg	4	M123
3	End cap	4	M002
4	M6 x 25mm security screw	4	B137
5	M6 spring washer	8	W004
6	M6 x 12mm flat washer	4	W003
7	Front Right pad FR	1	M546
8	Front Left pad FL	1	M547
9	Rear Right pad RR	1	M548
10	Rear Left pad RL	1	M549
11	Rubber skirt Left (short)	2	M550
12	Rubber skirt Right (short)	2	M551
13	Rubber skirt Left (long)	2	M552
14	Rubber skirt Right (long)	2	M553
15	M10 x 38mm washer	4	W022
16	M10 x 20mm hex bolt	4	B003
17	M10 shakeproof washer	4	W021
18	Trim cover	4	M560
19	M6 x 30mm socket hd cap screw	4	B047
20	M10 channel nut	4	N024
21	Pad cover plate	4	M126
22	M6 x 16mm flat washer	4	W031
23	3mm x 6mm O-ring	4	C347
24	Copper/foam washer	4	C967
25	5mm security allen key	1	H021
26	Fitting Instruction	1	R106

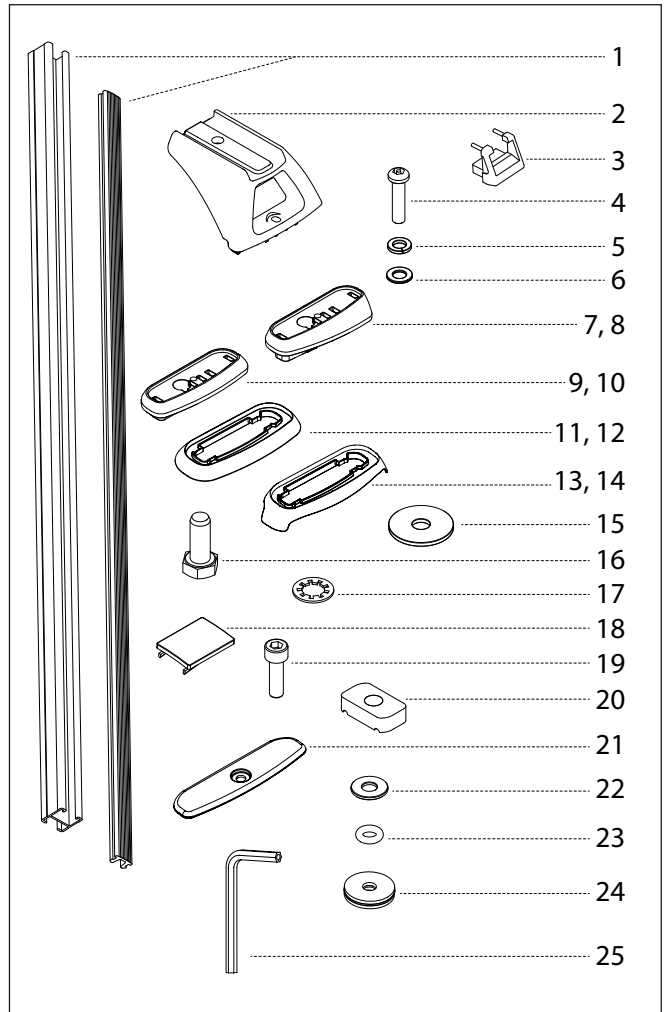

Tools required:

- Allen key, included.
- Tape measure.
- Torque wrench.
- 16mm spanner.
- Flat head screwdriver.
- Rubber mallet.

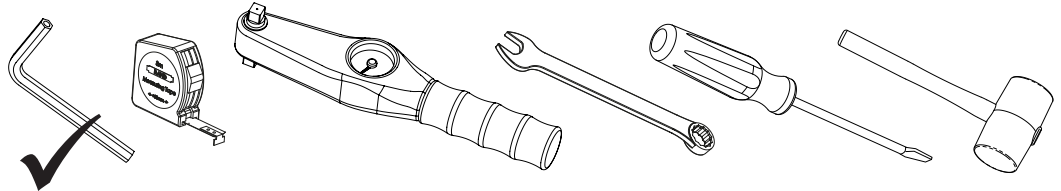

Select Amarok model, with or without roof trim.

Volkswagen Amarok
with roof trim.

Steps;
1-3, 5-9, 11-17.



Volkswagen Amarok
without roof trim.

Steps;
2, 4-5, 7-8, 10-17.

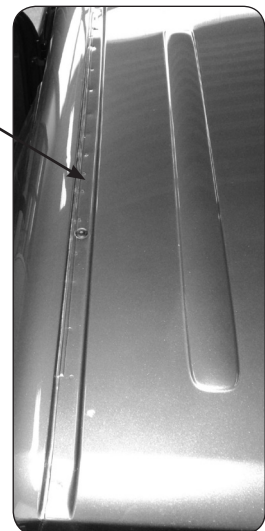



RLCP24 - Volkswagen Amarok

1

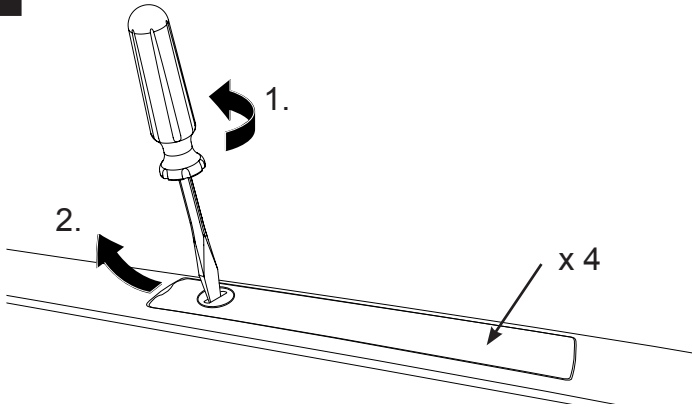

Remove roof covers.

Unscrew half a turn anti-clockwise, remove cover.

2

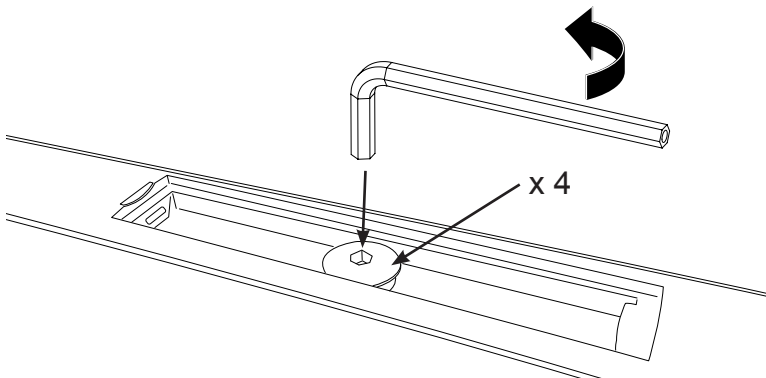

Remove roof screws.

Use supplied allen key.

3

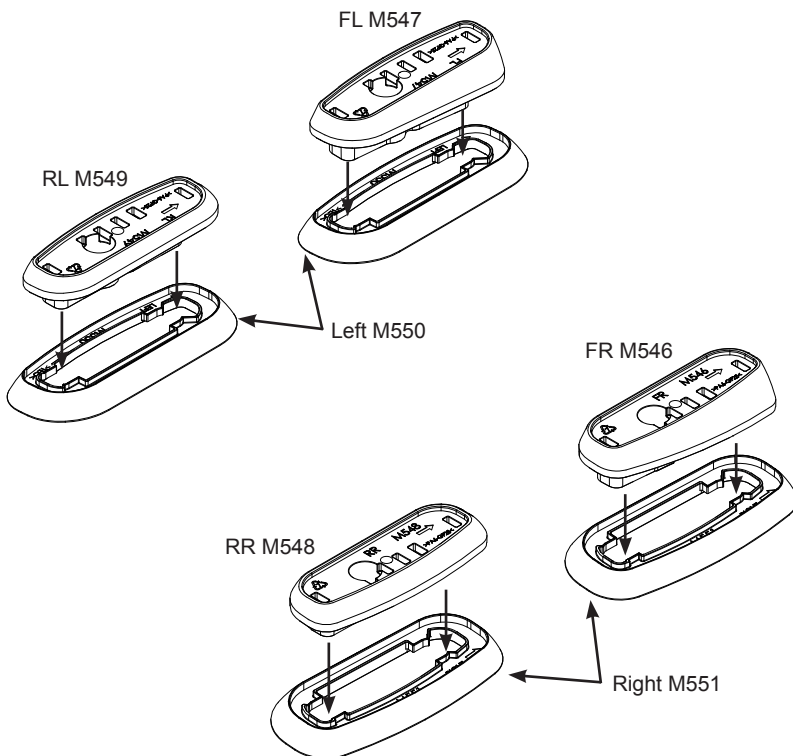

Attach short rubber skirt.

Front Left..... FL M547

Rear Left..... RL M549

Front Right..... FR M546

Rear Right RR M548

Left skirt..... Left M550

Right skirt..... Right M551

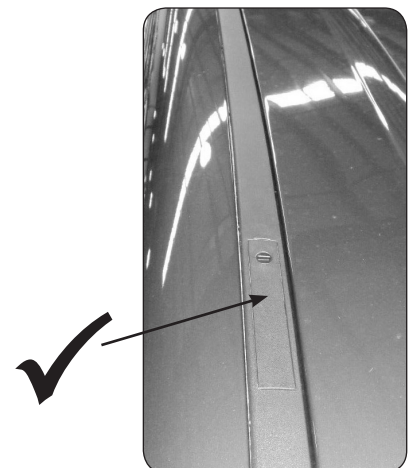



RLCP24 - Volkswagen Amarok

4

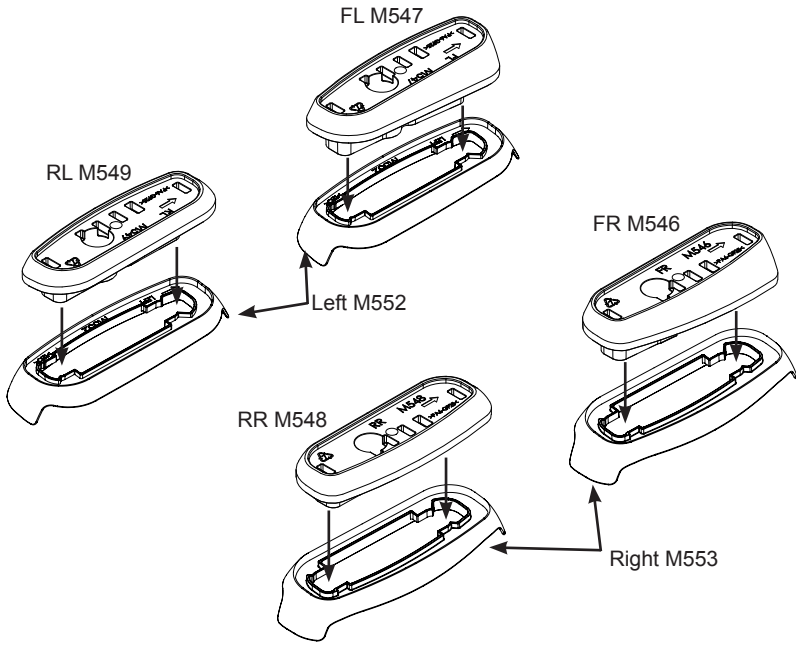

Attach long rubber skirt.

Front Left FL M547

Rear Left RL M549

Front Right FR M546

Rear Right RR M548

Left skirt Left M552

Right skirt Right M553

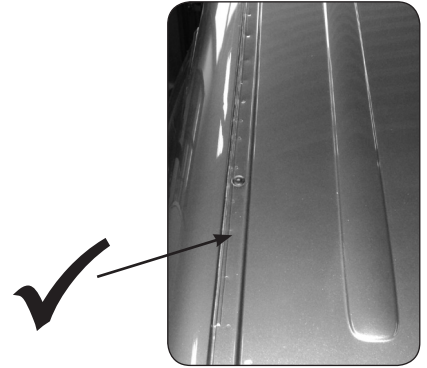

5

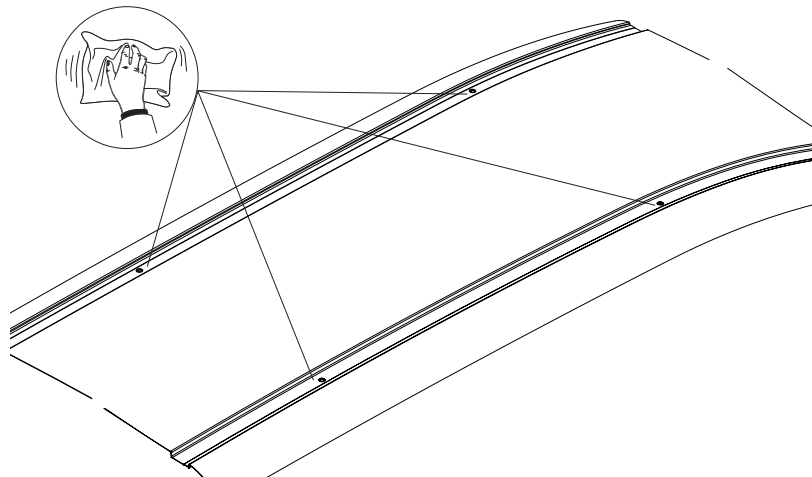

Clean mounting surface.

6

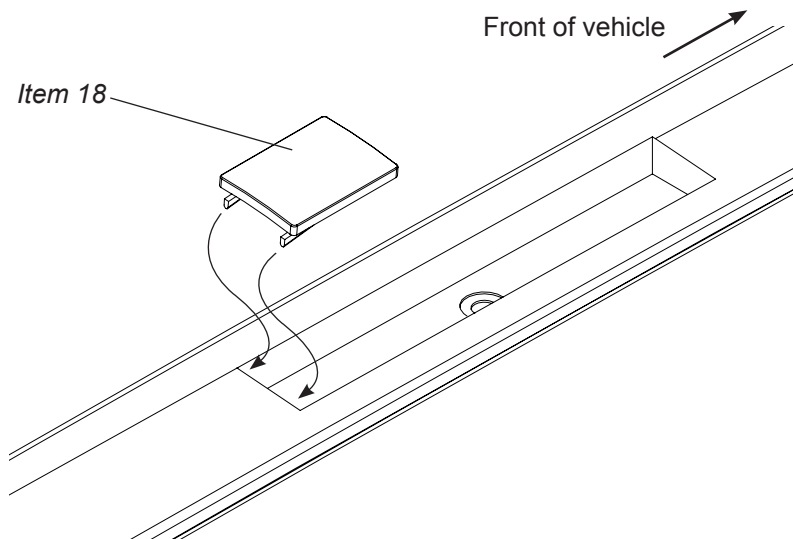

Attach trim cover.

Fit trim covers, 4 places. Only for vehicles with roof trim.

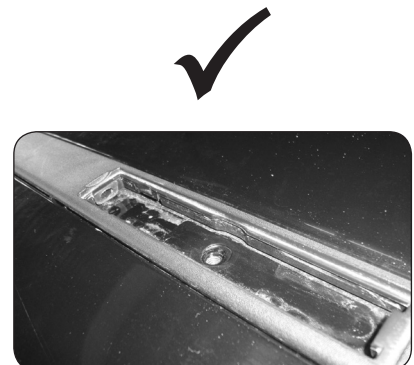



RLCP24 - Volkswagen Amarok

7

x 4

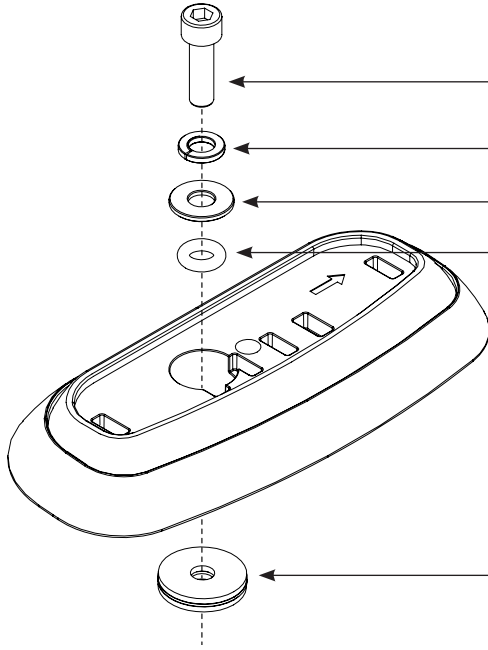

Attach pad mounting hardware.

M6 x 30mm SHCS

M6 spring washer

M6 x 16mm flat washer (*item 22*)

3mm x 6mm O-ring

Copper/foam washer

8



Rubber skirt.

Support rubber skirt when fitting to prevent it from folding under.

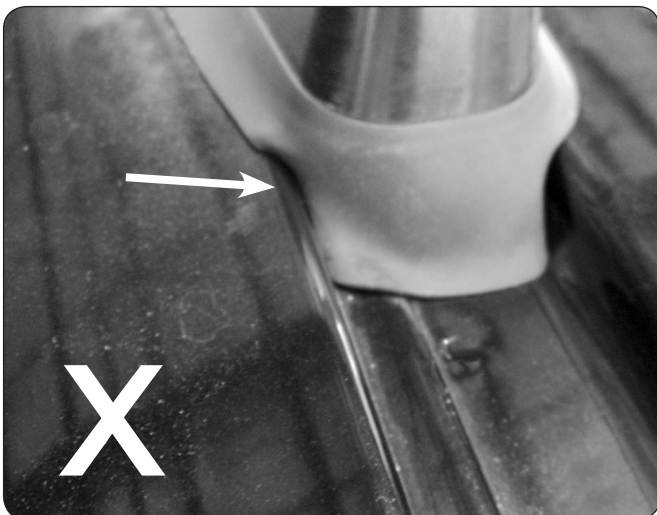
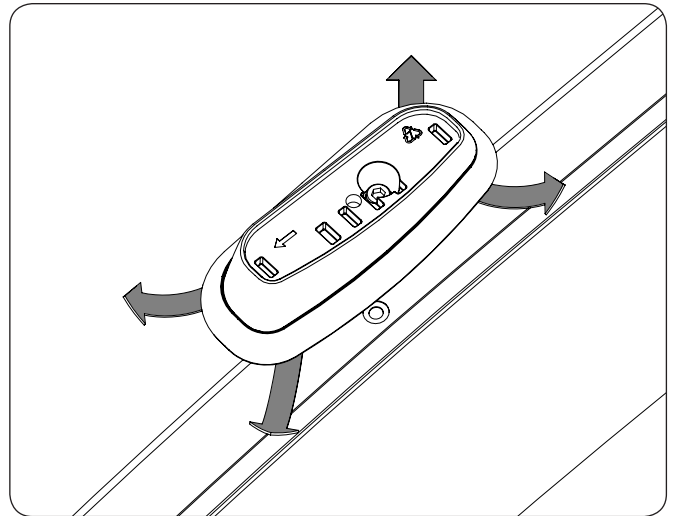
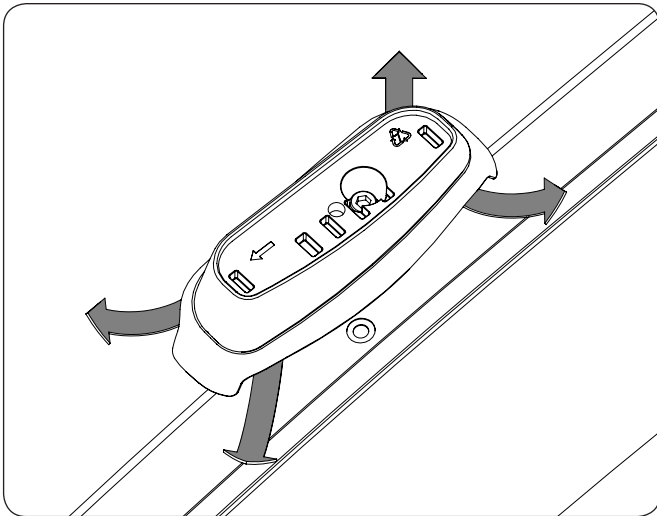



RLCP24 - Volkswagen Amarok

9

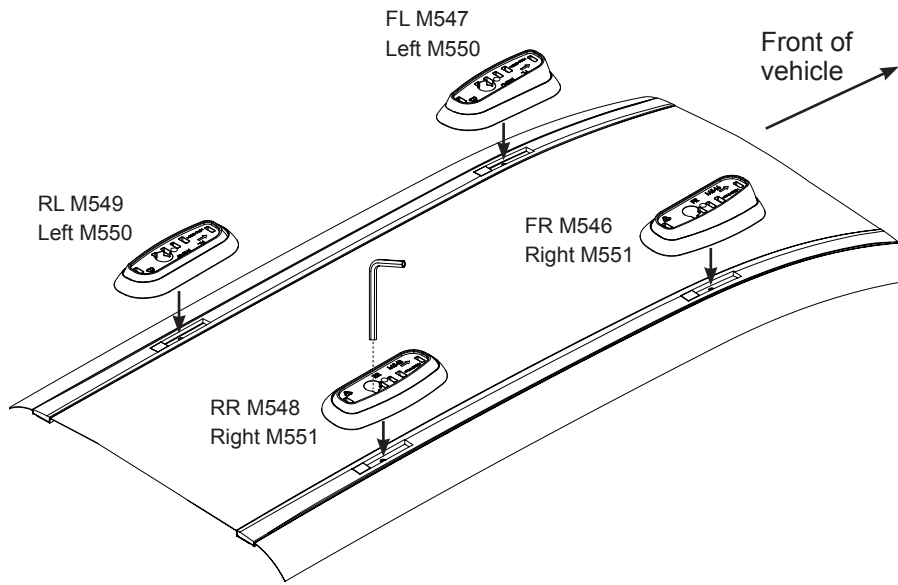

Fit pads to roof.

Fasten pads to roof.
Tighten M6 x 30mm screws, 5-6 Nm.

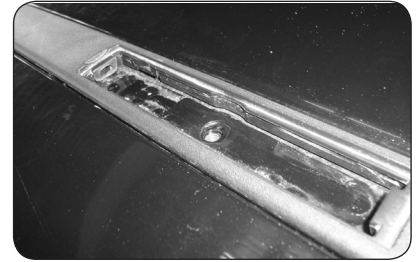

10

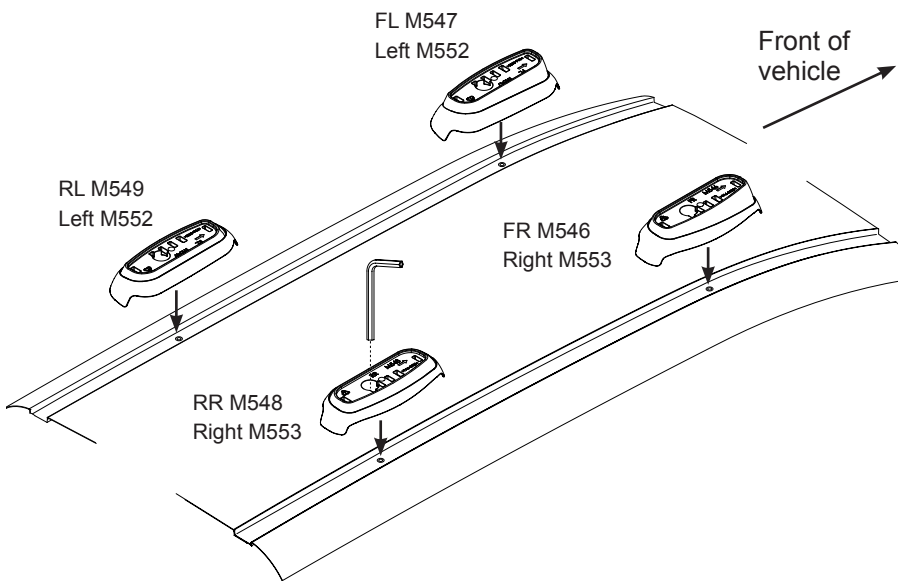

Fit pads to roof.

Fasten pads to roof.
Tighten M6 x 30mm screws, 5-6 Nm.

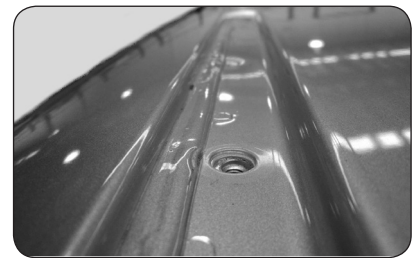

11

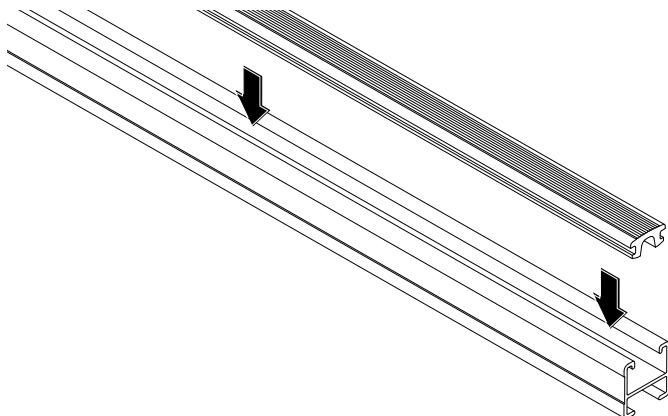

Crossbar rubber.

Insert crossbar rubber into front and rear crossbar.



RLCP24 - Volkswagen Amarok

12

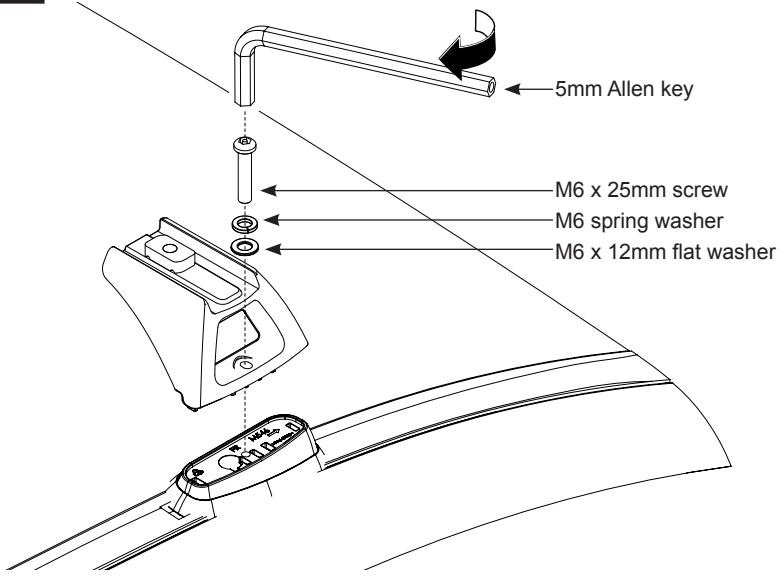

Attach legs.

Attach all 4 legs to pads. Do not fully tighten at this stage.

13

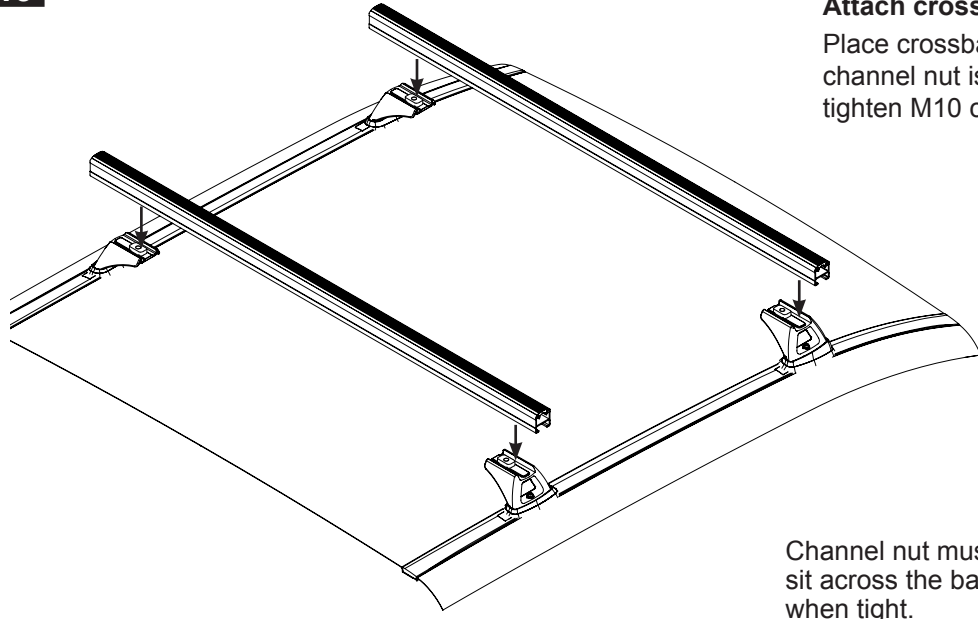

Attach crossbars.

Place crossbars on top of legs. Make sure channel nut is across the bar. Lightly finger tighten M10 crossbar bolts.

Channel nut must sit across the bar when tight.

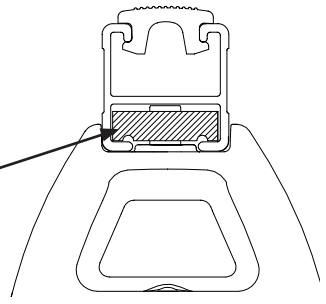

14

Equal crossbar overhang.

Slide crossbars to achieve equal overhang.

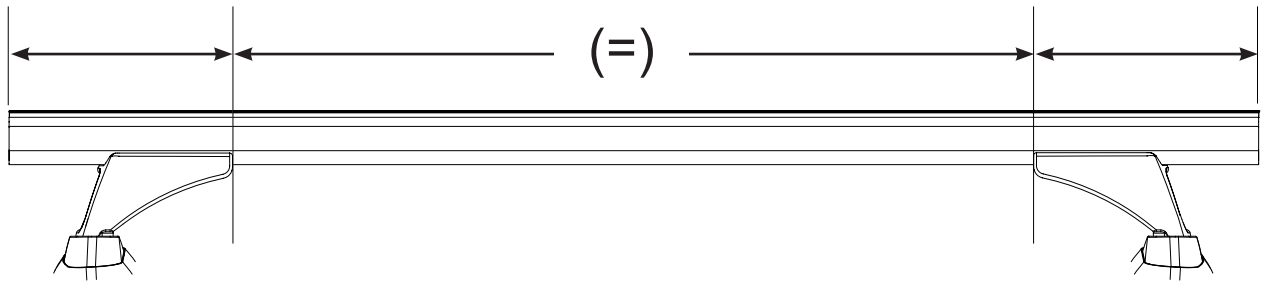



RLCP24 - Volkswagen Amarok

15

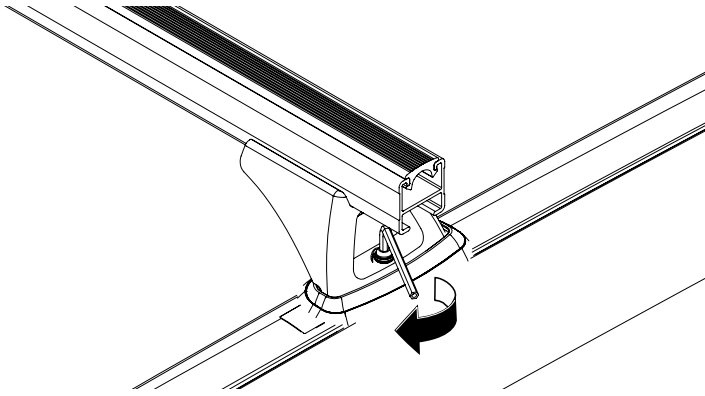

Tighten M6 screws.

Evenly tighten both left and right side M6 leg screws. 3-4 Nm.

16

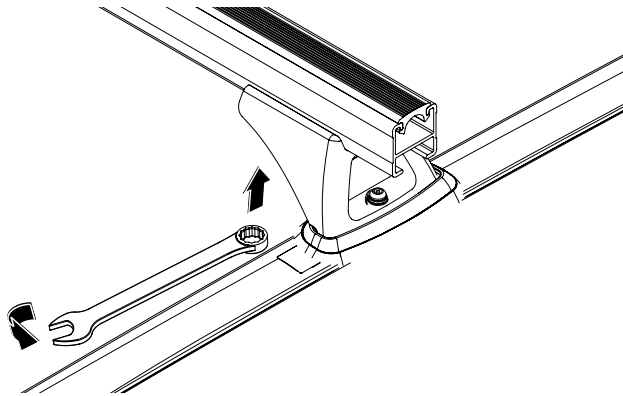

Tighten M10 bolts.

Evenly tighten both left and right side M10 crossbar bolts. 13-14 Nm.

17

End caps.

Knock end caps into each end of crossbars. A rubber mallet may be needed.

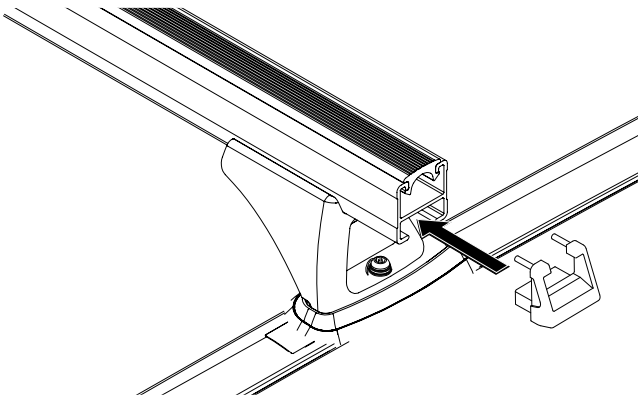

When crossbars are removed.

Attach cover plates (*item 21*) when crossbars are removed. Tighten screws 3-4 Nm.

