

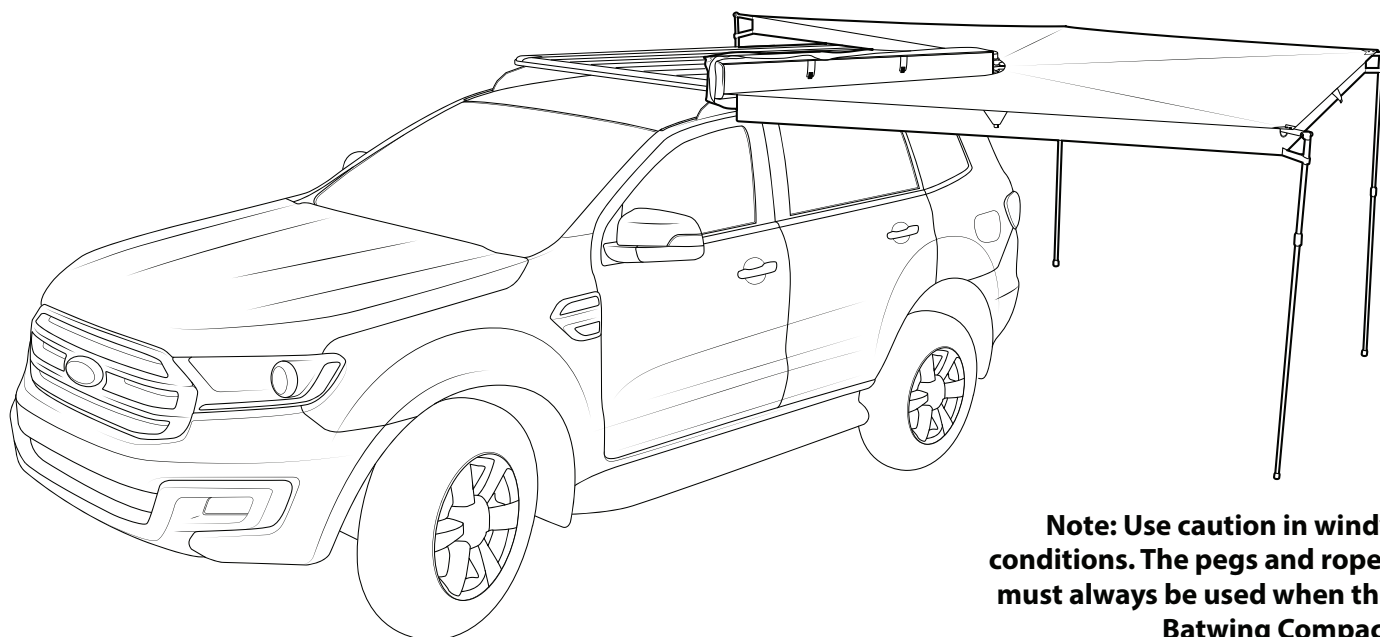

# RHINO-RACK

33300 LH - Batwing Compact Awning  
33400 RH - Batwing Compact Awning

- |  |  |
|--|--|
| 1. <input type="checkbox"/> Check Part No./Kit is correct              | 3. <input type="checkbox"/> Fit roof rack accessory                    |
| 2. <input type="checkbox"/> Read through instruction before installing | 4. <input type="checkbox"/> Check and recheck all fasteners are secure |



**Note: Use caution in windy conditions. The pegs and ropes must always be used when the Batwing Compact Awning is open.**

## Important Information

### Recommendations

It is essential that all bolt connections be checked after driving a short distance when you first install your Rhino-Rack Batwing Compact Awning. Bolt connections should be checked again at regular intervals depending on road conditions, usage, loads and distances travelled. You should also check the roof bars each time they are refitted.

**Use only non-stretch fastening ropes or straps.**

Please remove Batwing Compact Awning and crossbars when putting vehicle through an automatic car wash. Do not stow away the awning for long periods if it is wet. You must allow the awning material to dry completely before storing for extended periods of time. When rolling up the awning, avoid excessive bunching up of the material before stowing. The awning should be rolled up as neatly as possible following the instruction on page 9.

### Torque settings

Unless stated otherwise in these instructions, all fasteners should be set to the following torque settings - M6: 4-5Nm (3-4lbs/ft), M8: 8-10Nm (6-7.5lbs/ft) and M10: 16-18Nm (12-13lbs/ft).

### Load Ratings

With the addition of the Batwing Compact Awning, the load capacity of your crossbars will have to be adjusted accordingly. The Batwing Compact Awning with mounting brackets weighs approximately 20kg.

### Note for Dealers and Fitters

It is your responsibility to ensure this fitting instruction is given to the end user or client

Rhino-Rack

22 Hanson St, Eastern Creek,

NSW 2766, Australia.

(Ph) (02) 8846 1900

rhinorack.com.au

Document No: R1816

Prepared By: Kayle Everett

Authorised By: Chris Murty

Fit Time: 15min

Issue No: 04

Issue Date: 11/10/2018

These instructions remain the property of Rhino-Rack Australia Pty Ltd and may not be used or changed for any other purpose than intended.

# RHINO-RACK

33300 LH, 33400 RH - Batwing Compact

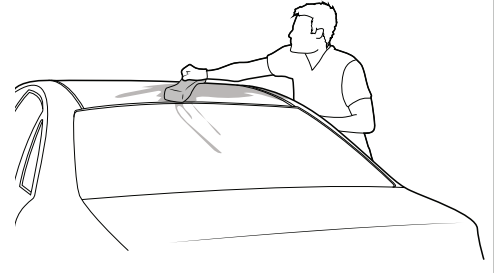
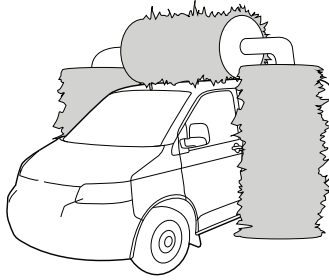

If awning is wet, be sure to dry before you stow.

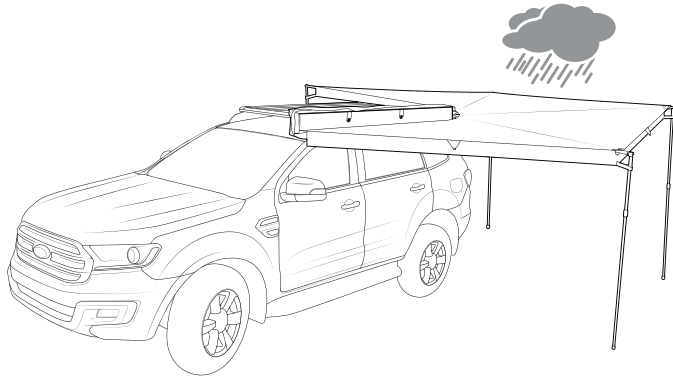

Always use sand screws (31113, sold as separate) when awning is open on beach or sand.

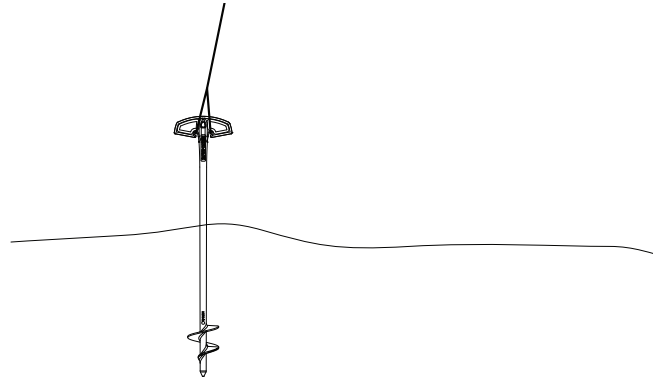

Always use guy ropes when awning is deployed.

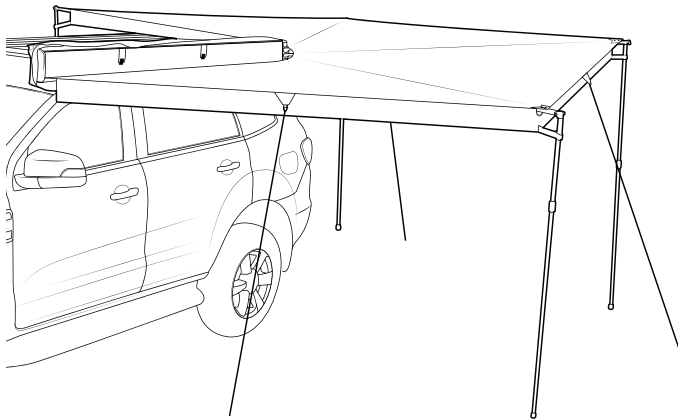

Do not use the awning as a means to hoist your body weight up or to the roof of the vehicle.

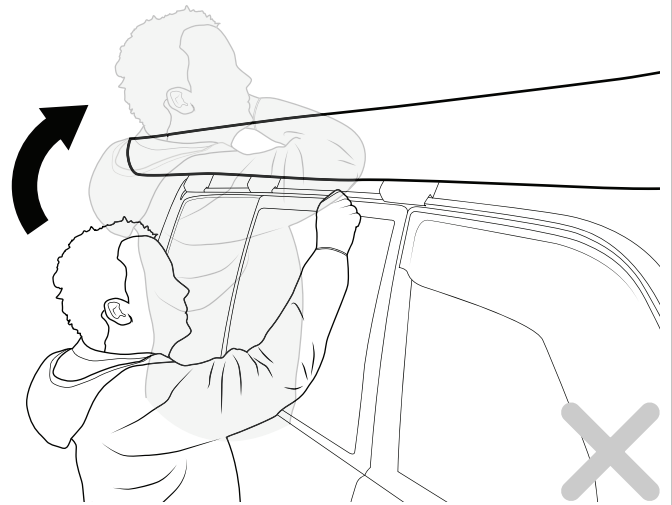

Be aware of the effects of wind on the open awning. It is advised that the awning be stowed away in strong winds. **Do not leave your awning unattended while open, weather conditions can change suddenly. Avoid setup in windy conditions.**

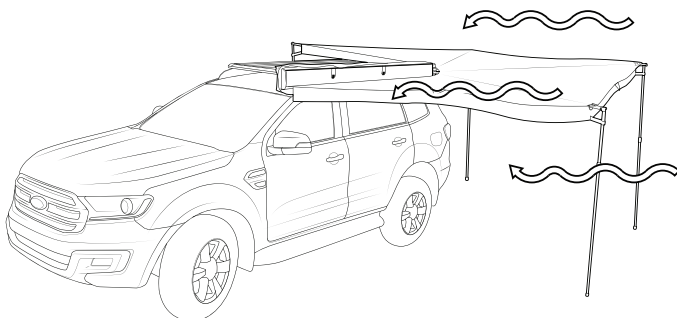

**Warning:** Shade does not provide 100% protection. Some UV can still reach you in the shade by reflecting off surrounding surfaces. Always combine shade with clothing, a hat, sunglasses and sunscreen.

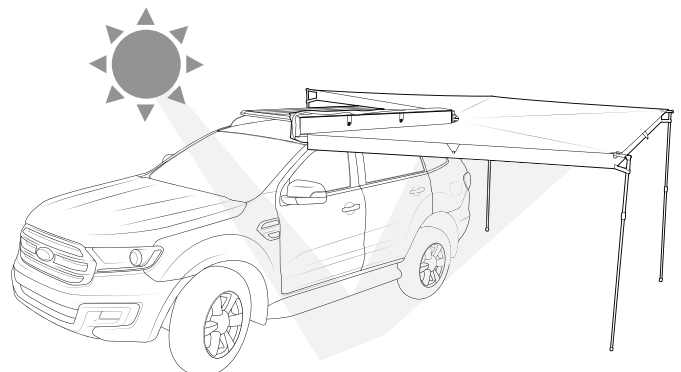

# RHINO-RACK

33300 LH, 33400 RH - Batwing Compact

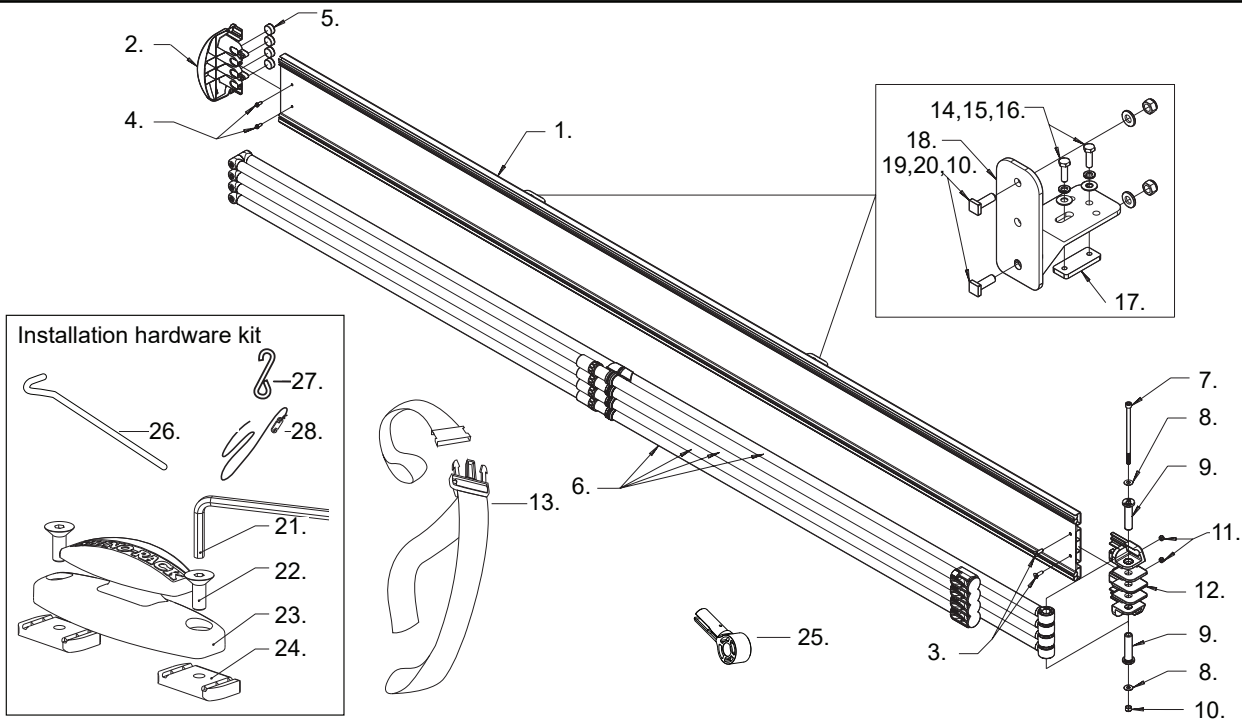

Item	Assembled Batwing	Qty	Part No.
1a	Batwing Main Extrusion	1	A974
1b	Batwing Compact Bag	1	SP288 LH SP289 RH
2	Batwing End Cap	1	M930
3	M6 x 20mm CSK Screw	2	B163
4	Phillips Screw 8G x 16mm	2	B176
5	Batwing End Cap Magnet	4	CA1796
6a	Batwing Spar Support RH	4	SUB0787
6b	Batwing Spar Support LH		SUB0788
7	M8 x 150mm Axle Bolt s/s	1	C775
8	M8 x 17mm Flat Washer	2	W020
9	Batwing Spar Hinge Pin	2	M938
10	M8 Nyloc Nut	1	N028
11	M6 Nyloc Nut	2	N013
12	Spar Hinge Casting	1	CA1797
13	Retention Strap	1	CA1871

Item	Hardware kit	Qty	Part No.
14	M6 x 20mm Hex Bolt BLK	4	B082
15	M6 Spring Washer	4	W004
16	M6 x 16mm Flat Washer	4	W031
17	Plate Nut	2	C838
18	Pioneer Awning Bracket	2	CA1816
19	M8 x 23mm T-bolt BLK	4	C779
20	M8 x 17mm Flat Washer BLK	4	W020
10	M8 Nyloc Nut	4	N028
21	Allen Key 4mm (H001)	1	CA1834
22	M6 x 16mm CSK Screw 4mm	2	
23	Pickup Moulding (SP202)	1	
24	M6 Channel Nut (N002)	2	CA1175
25	Spare Hinge Moulding	2	

Item	Peg Bag	Qty	Part No.
26	Metal Peg	10	C909
27	Guy Rope 'S' Hook	4	C911
28	Guy Rope	8	C910
29	Bag (LH or RH)	1	SP288 LH
		1	SP289 RH

**Tools required**

- 10 and 13mm socket wrench
- 6mm allen key
- Hammer/ mallet for peg installation

## Installation and setup

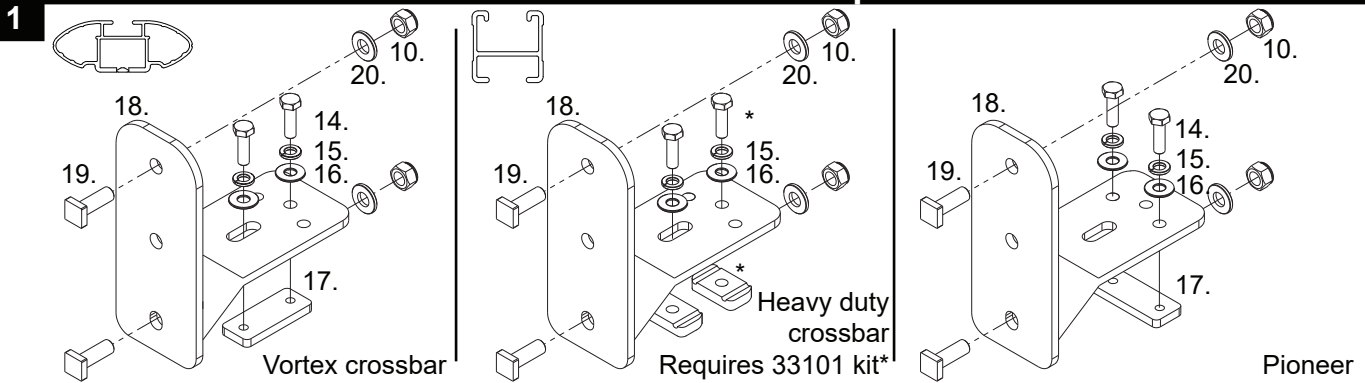

# RHINO-RACK

33300 LH, 33400 RH - Batwing Compact

- 2** Install the pick up mounting points at the rear of the vehicle, on the opposite side you intend to fix the Batwing awning to. Tighten in place with allen key provided.

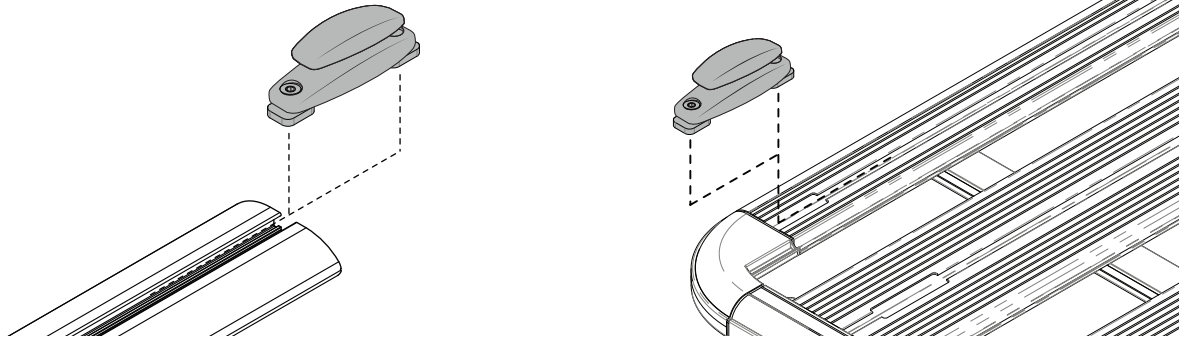

- 3** Slide the bracket assemblies into either of the slots of the Batwing awning. Finger tighten only.

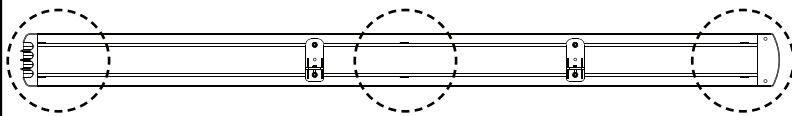

Be aware of height differences when changing bracket orientation. Confirm door clearance.

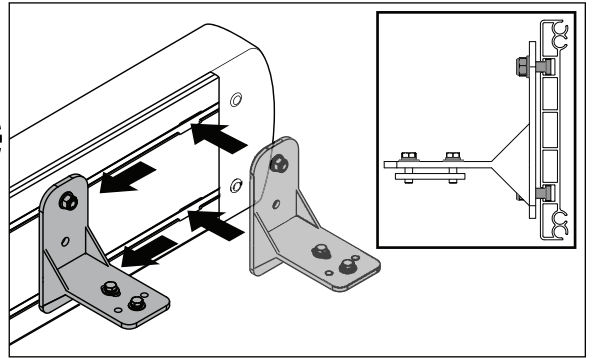
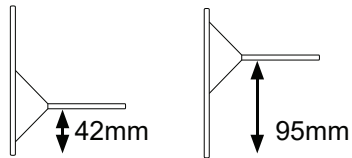

**4**

Vortex crossbar

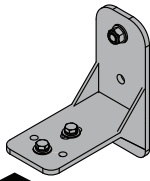
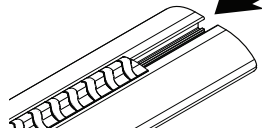

Heavy duty crossbar

\*Requires purchase of 33101 hardware kit.

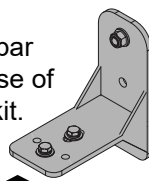
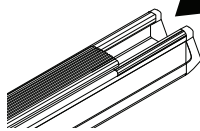

Pioneer

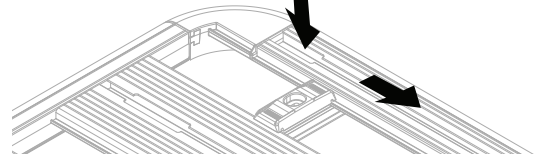

- 5** Tighten to 4-5Nm with a 13mm socket wrench. Be aware of tail gate position and adjust awning position accordingly.

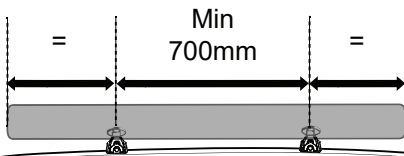

Be sure hardware is located correctly within the crossbar.

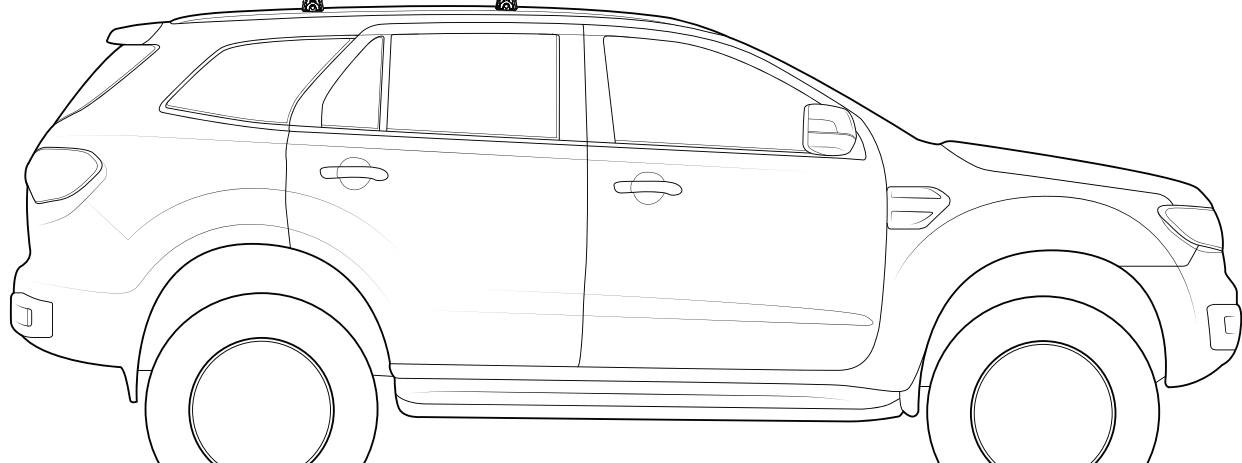
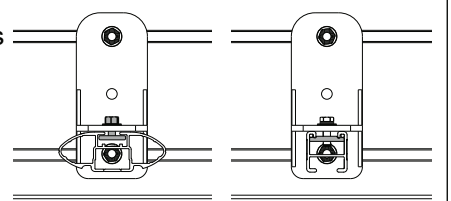

# RHINO-RACK

33300 LH, 33400 RH - Batwing Compact

6

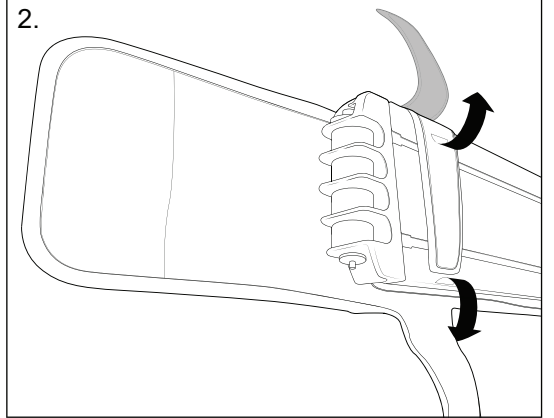
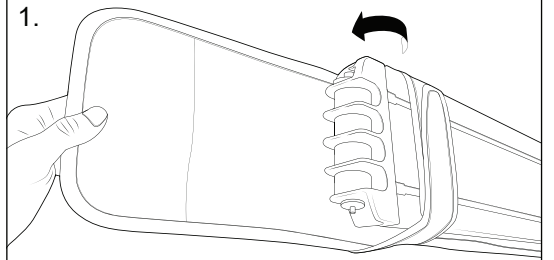
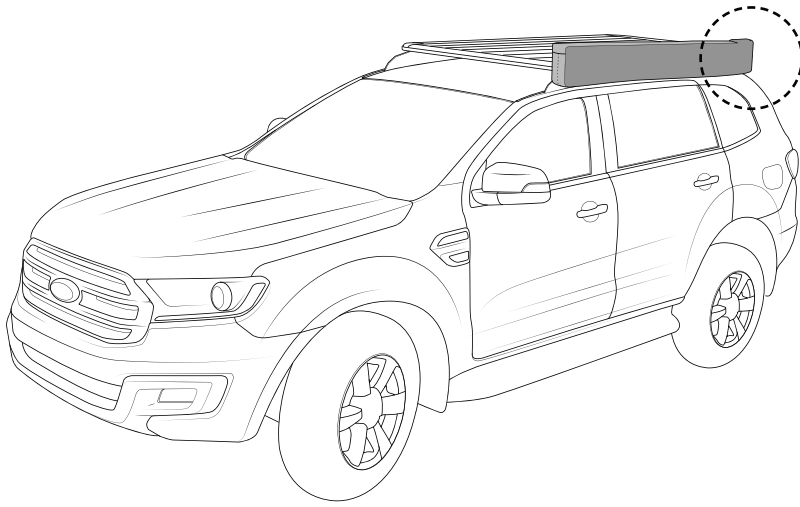

7 Unzip the bag.

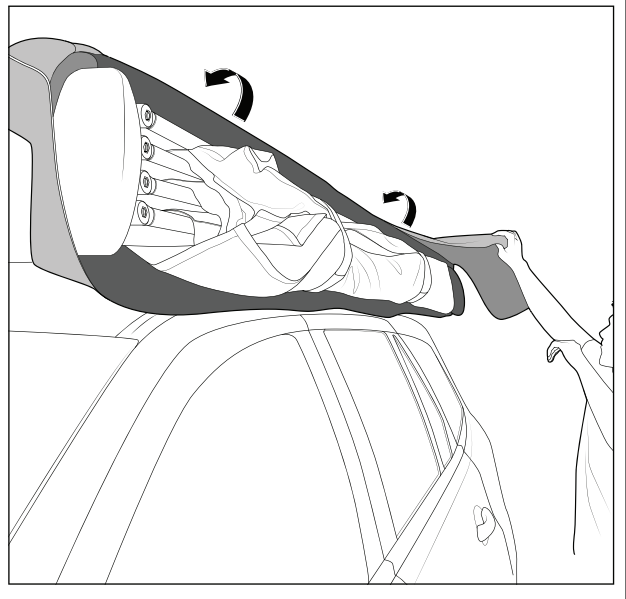
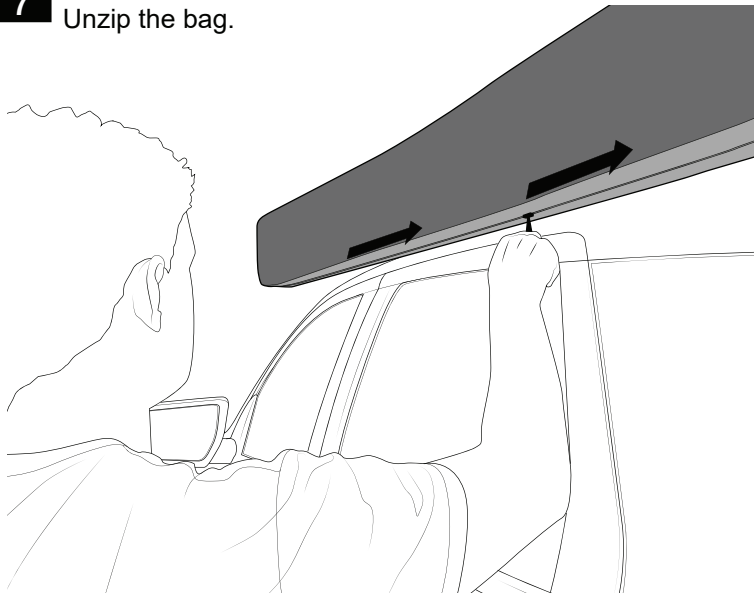

8 Remove the peg bag from the peg pouch at the rear of the awning.

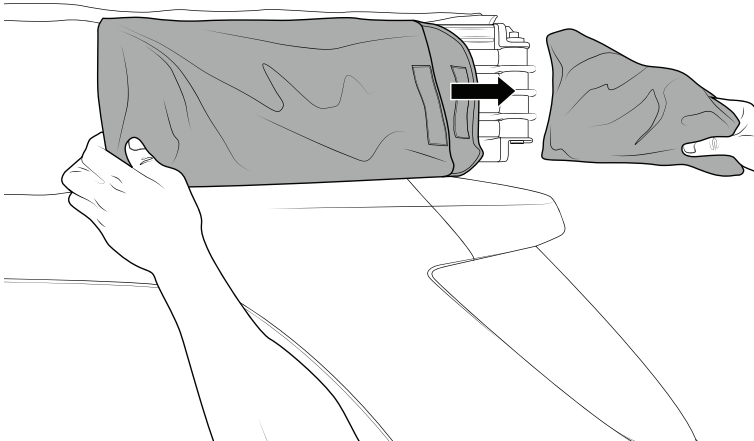

Flip the peg pouch over the back of the awning.

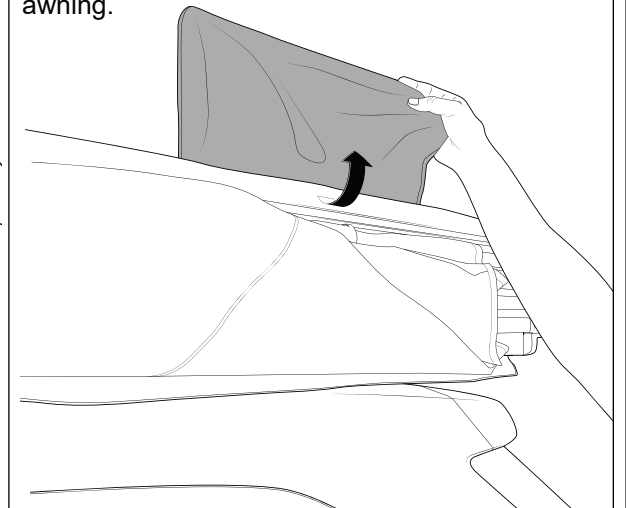

# RHINO-RACK

33300 LH, 33400 RH - Batwing Compact

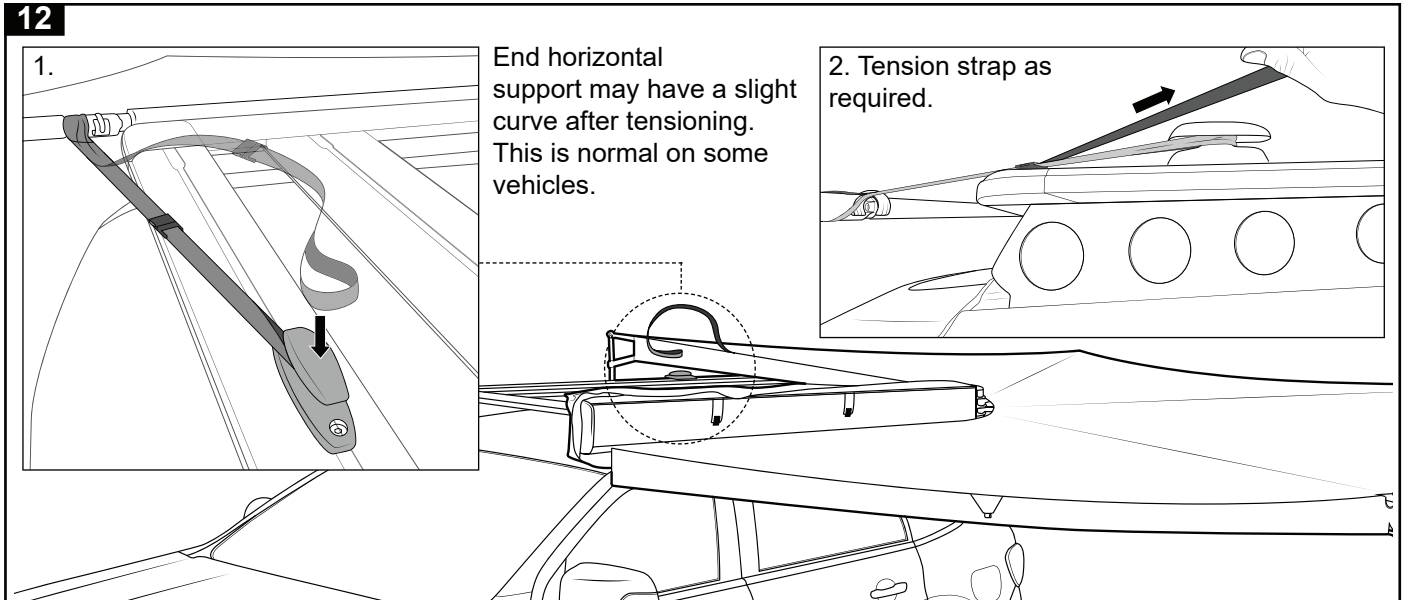
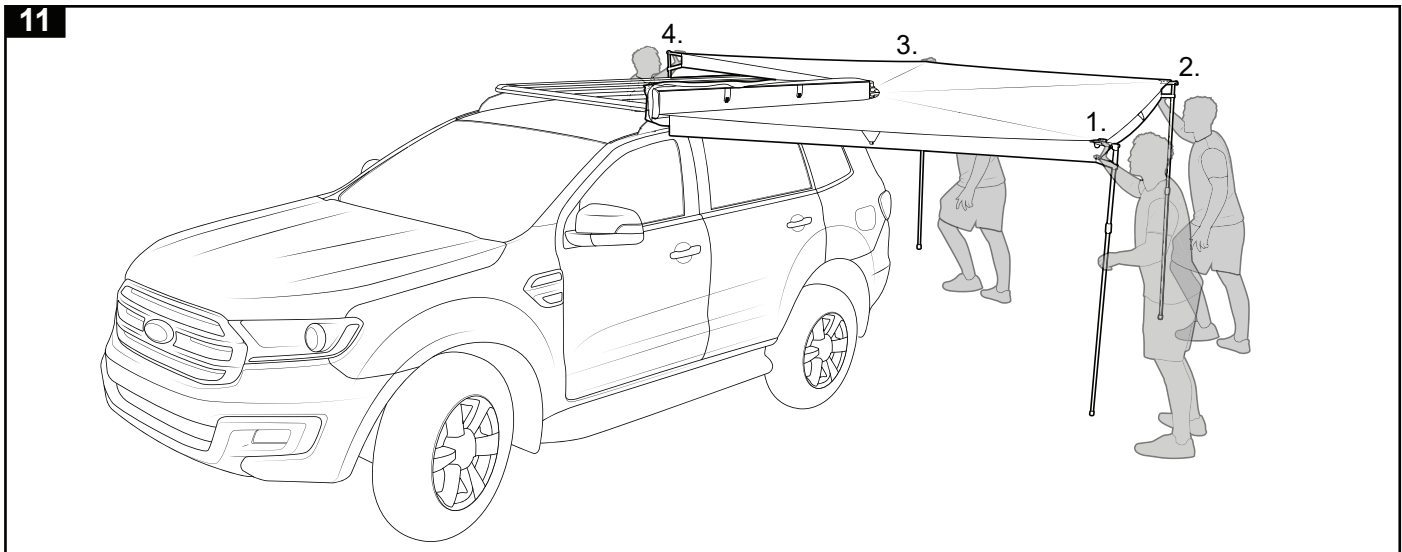
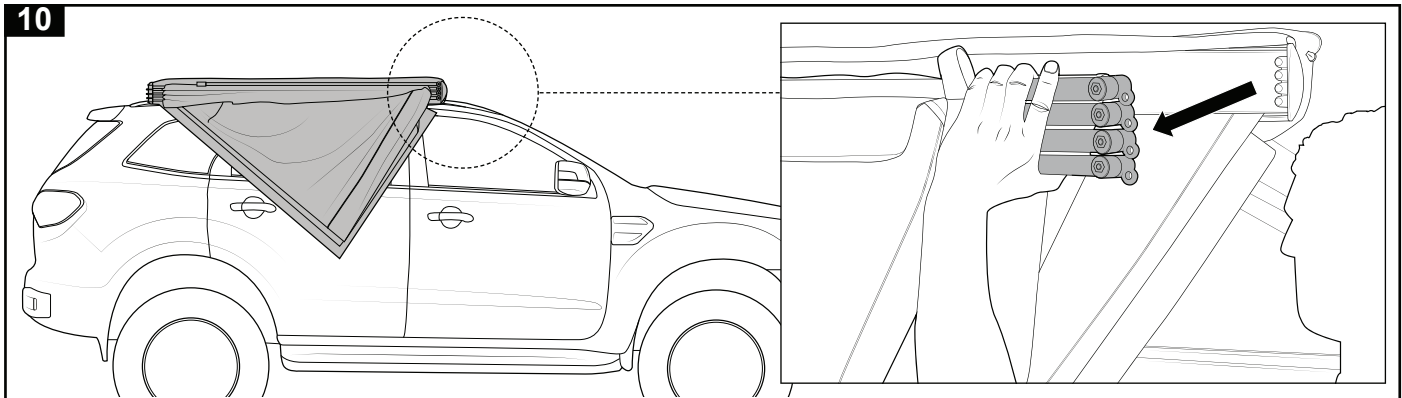
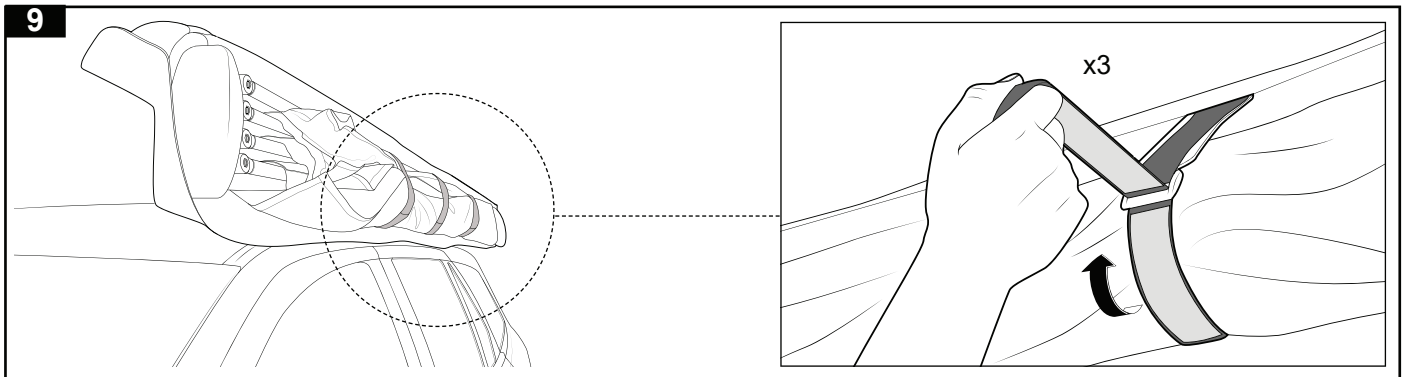

# RHINO-RACK

33300 LH, 33400 RH - Batwing Compact

- 13** Unclasp the supports and drop them down into position.

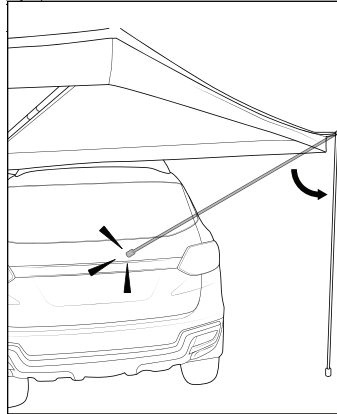
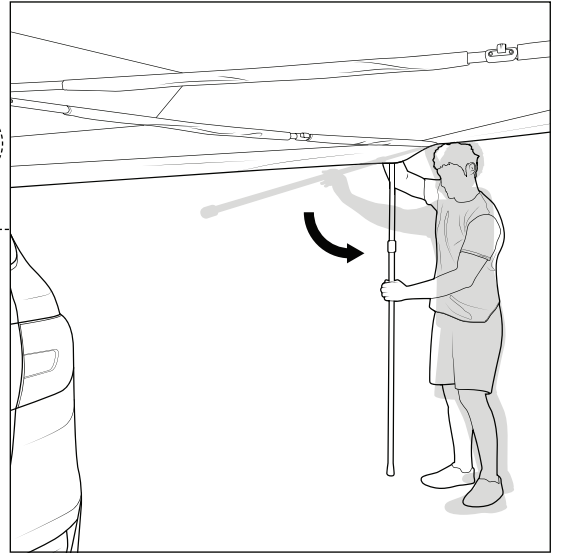
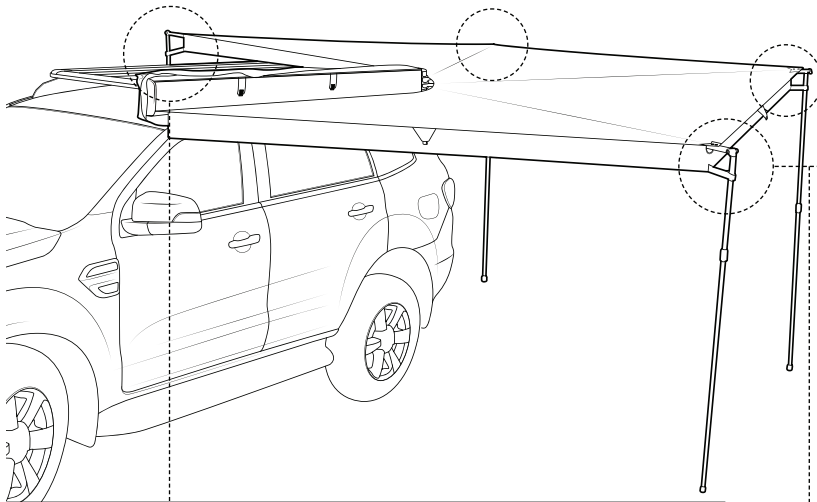

Be aware on some vehicles the 4th support can hit the rear of the vehicle when dropped down. Simply undo the tension strap, drop the support, then re-attach the retention strap.

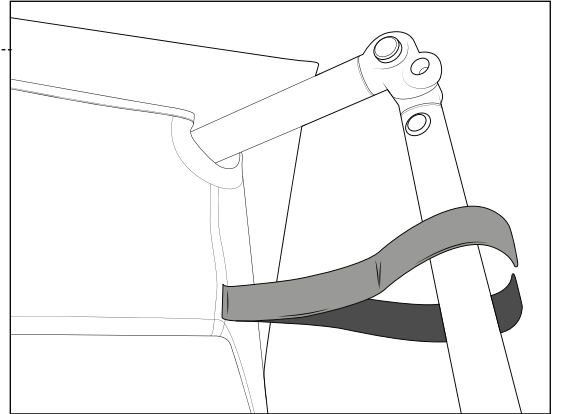

- 14** Tighten the support poles in place at the selected height.

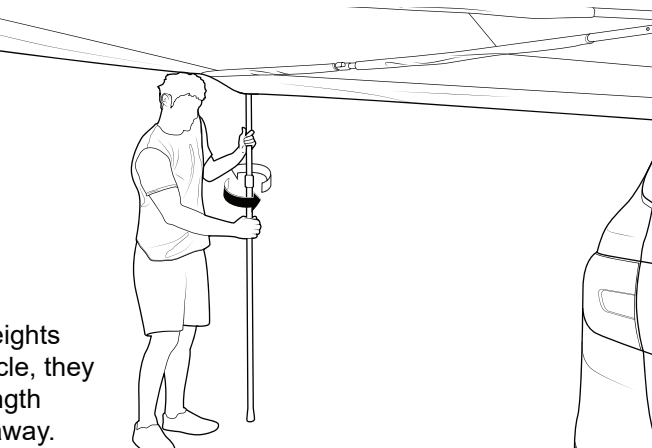

Note: Once these heights are set for your vehicle, they can be left at this length even when stowed away.

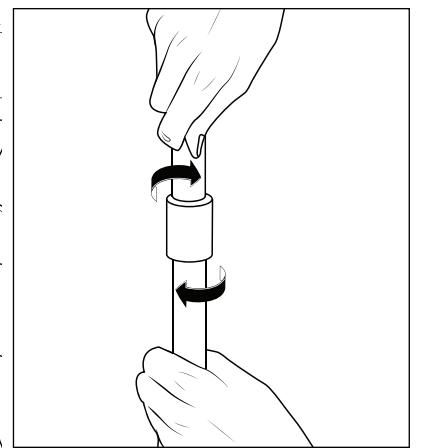

- 15** Drive a peg through the foot of the support. Pegs can be driven in both sides to lock the support down.

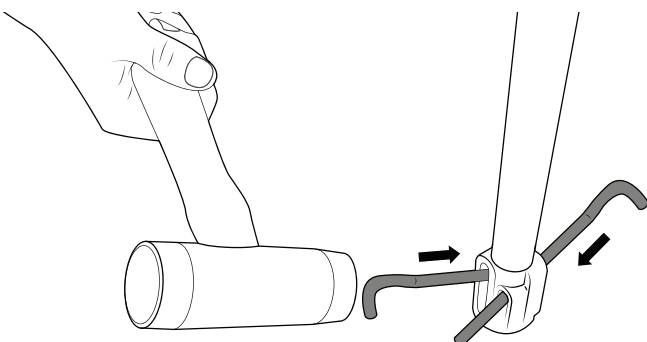

Leave a small gap to allow pegs to be removed easily.

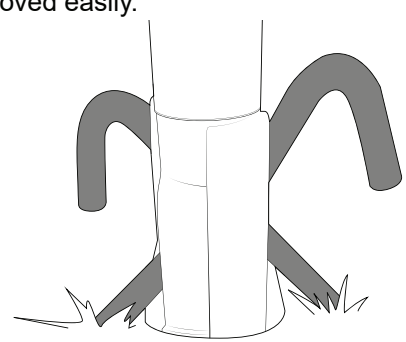

# RHINO-RACK

33300 LH, 33400 RH - Batwing Compact

- 16** Drive the metal pegs into suitable ground on the outside of the supports. Hook the ropes to the awning, fixing it in place as shown.

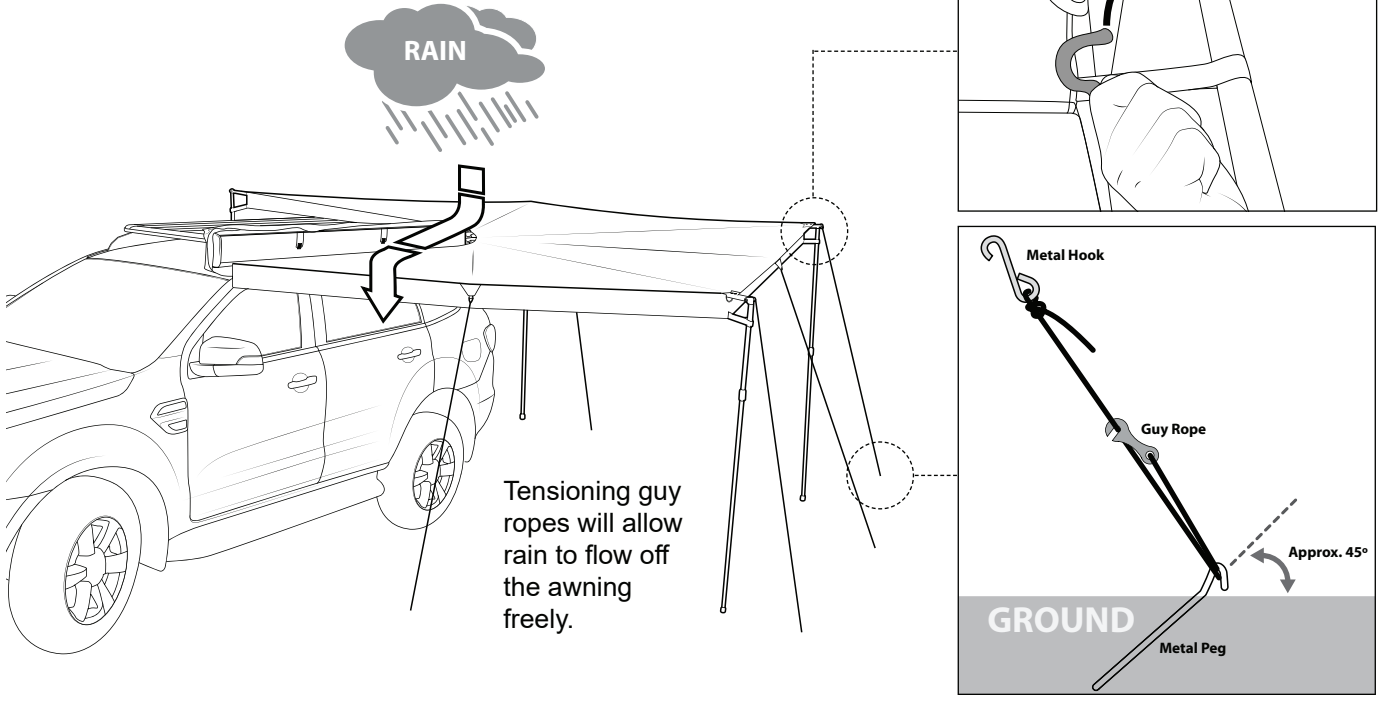

## Stowage instructions

- 17** Lift the support poles back up into their original position. Be sure they clip into place.

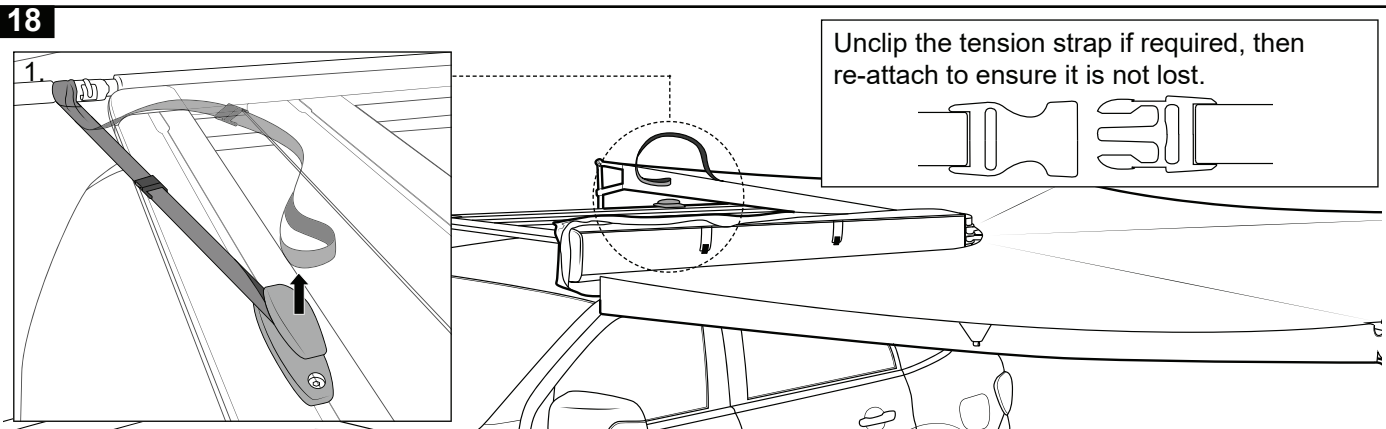
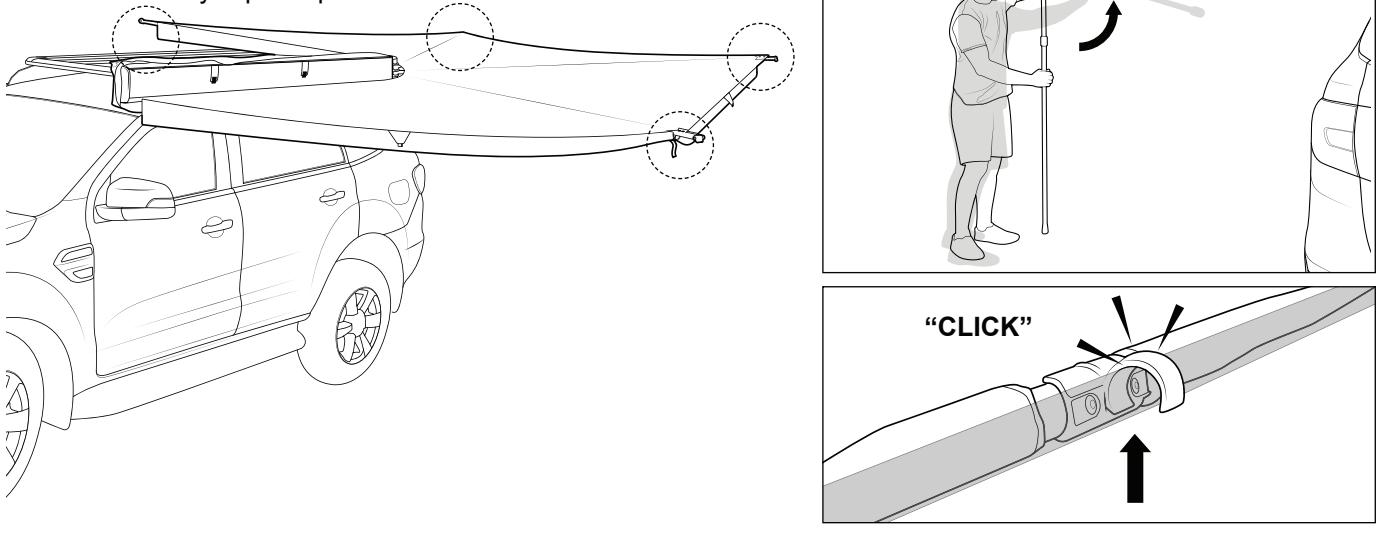



# RHINO-RACK

33300 LH, 33400 RH - Batwing Compact

- 19** Swing each arm back towards the body of the awning. As you move through positions 1 - 4, stack each arm on top of the one before it as shown. Place all 4 arms back onto the magnets at the same time.

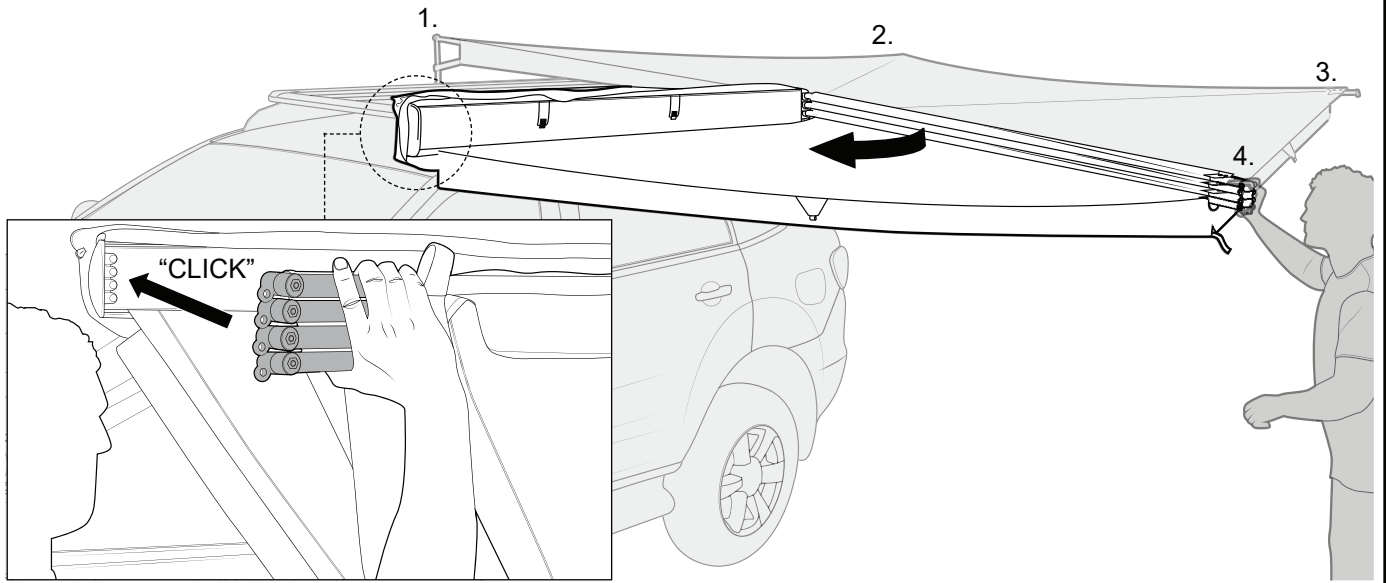

- 20** RHS shown:

1. Fold the awning material in half.

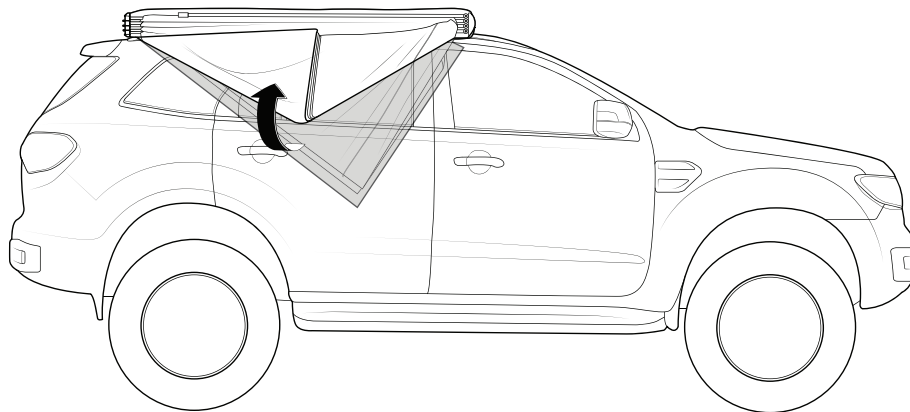

2. Roll the material from the front edge back up into its original setting.

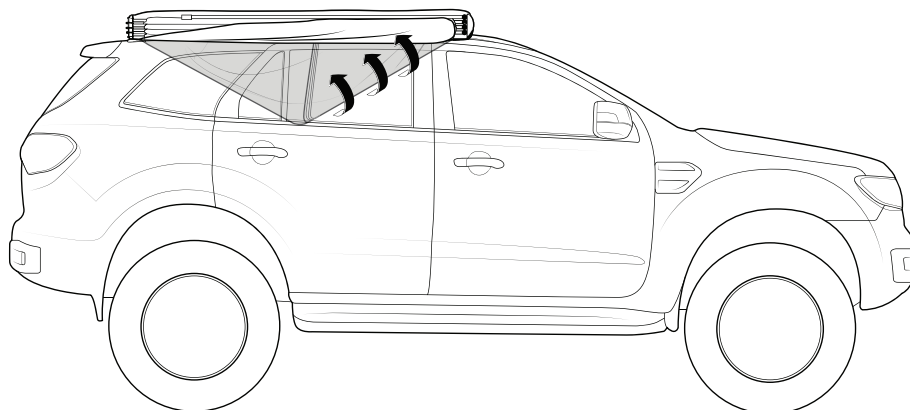

3.

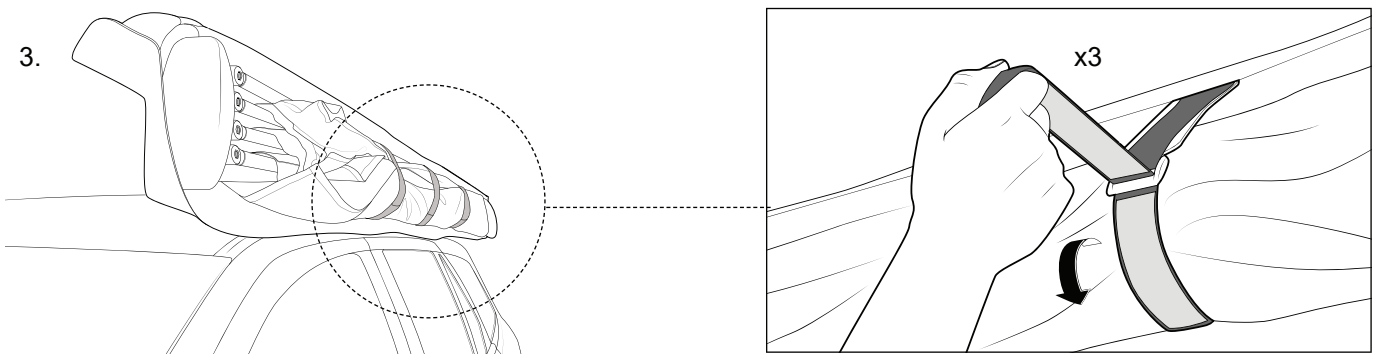

# RHINO-RACK

33300 LH, 33400 RH - Batwing Compact

- 21** Replace the metal pegs and guy ropes to their original position. Zip the outer bag closed.

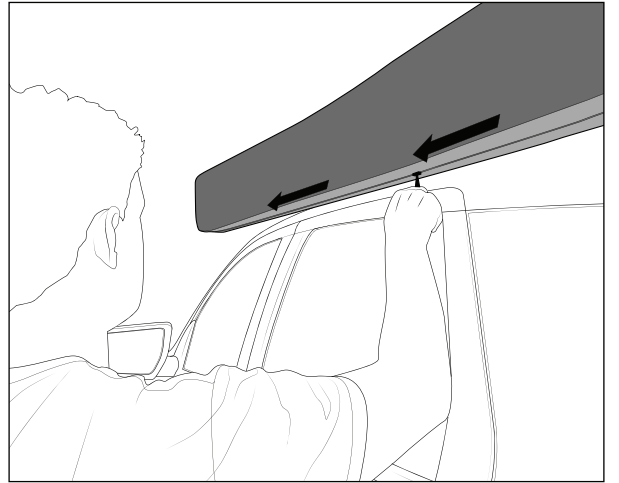
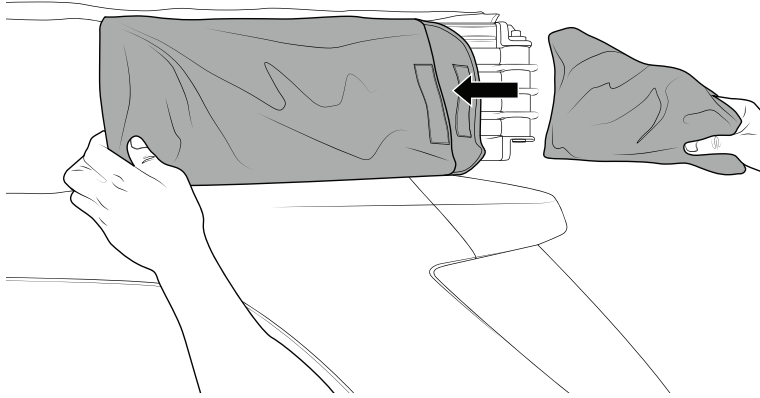

**22**

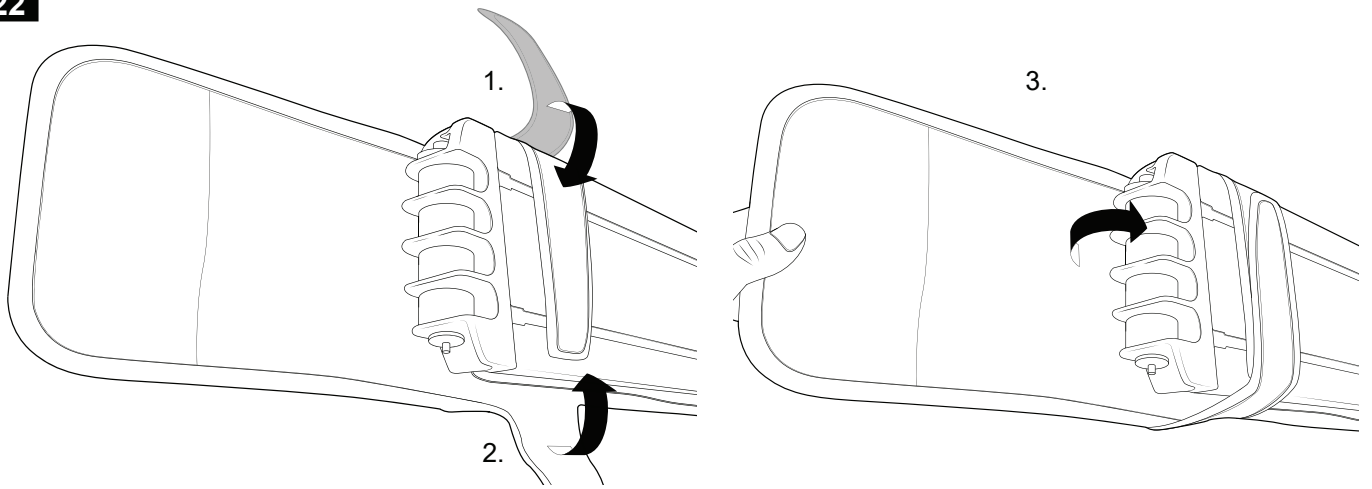

## Important Notes

- 1** The support arms are designed to allow slight adjustment by the end user. When housed, if the arms are not sitting flush with end cap (fig A), adjust the rotation on the arm using a phillips head screw driver (fig B).

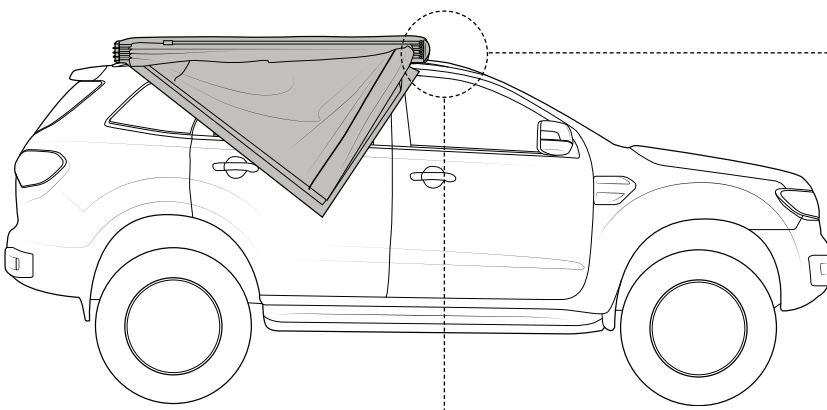

**X** (fig A) If the arm is off centre as shown, the magnet in the end cap will not secure the arm in place properly.

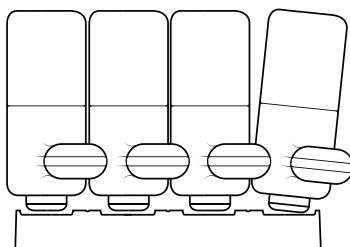

(fig B) Loosen the screw behind the drop down hinge, adjust the arm rotation and re-tighten the screw.

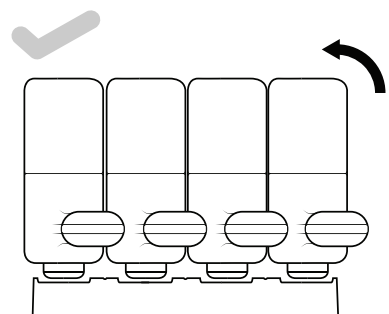
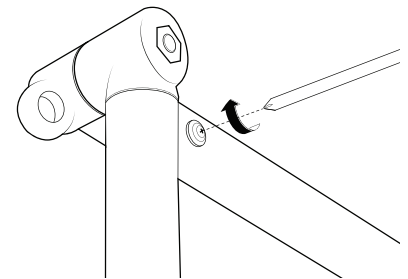

# RHINO-RACK

33300 LH, 33400 RH - Batwing Compact

**2a** Should a spar hinge be damaged from stronger than expected wind conditions, they can be replaced with the spare pieces provided. Remove awning from vehicle. Use a 13mm spanner and a 6mm allen key to undo the casting assembly.

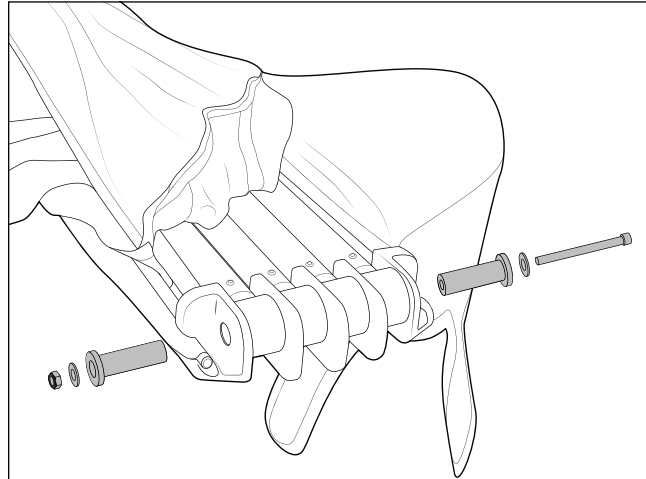
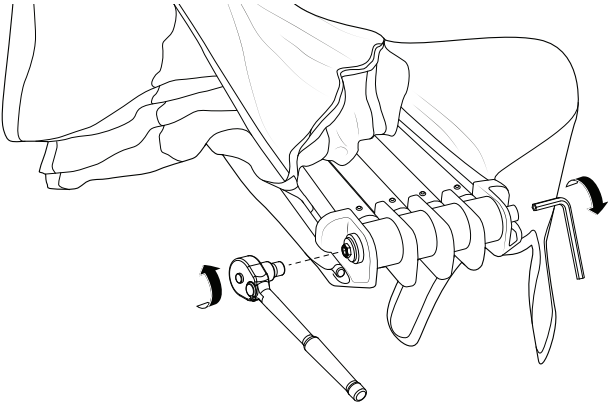

Remove the assembly pieces and store safely to the side.

**2b** Using a phillips head screw driver, remove the screw holding the damages hinge moulding in place. Replace with the spare hinge provided.

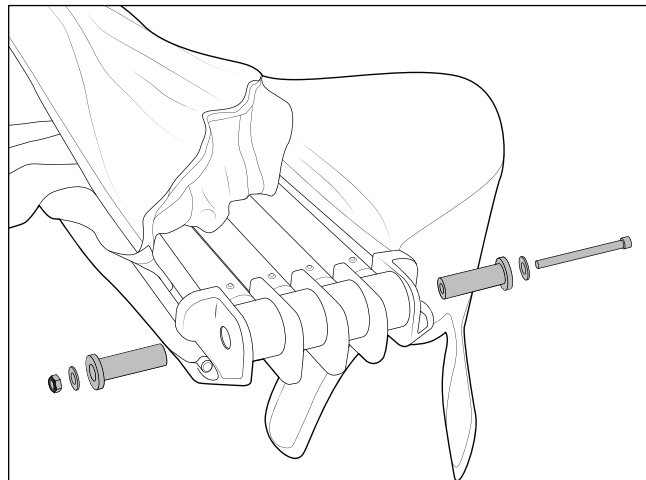
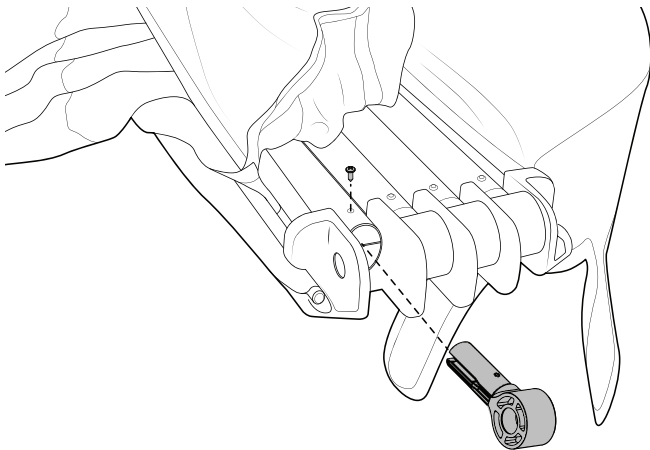

Replace the assembly pieces and tighten with a 13mm spanner and 6mm allen key.

**3a** To replace a damaged PVC bag:  
1 - Unzip the bag and remove the velcro straps.  
2 - Remove the plastic plugs in the rear of the bag. It is normal that these screws will be destroyed in the process.

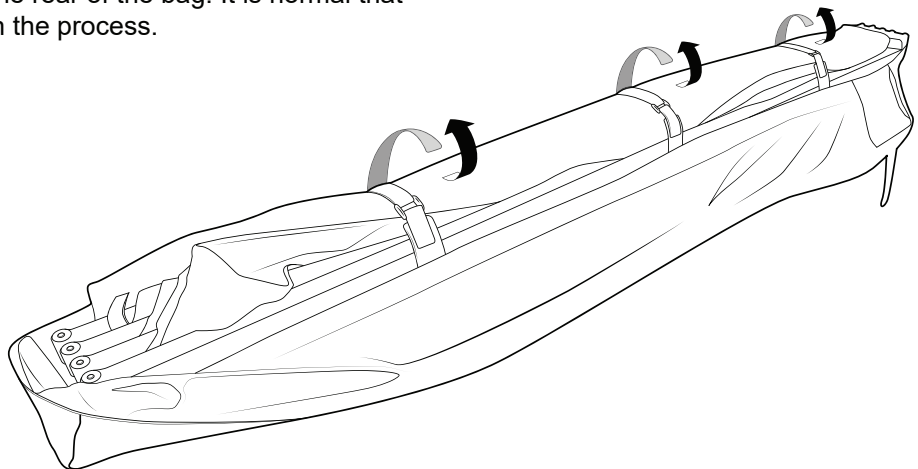
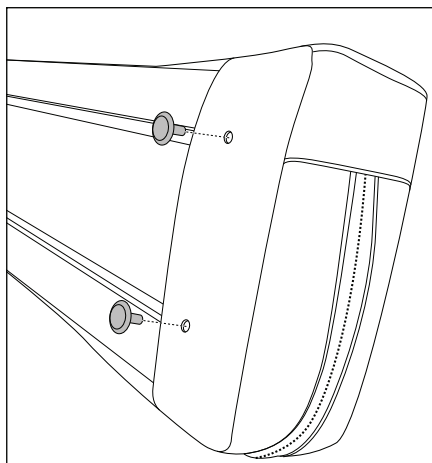

# RHINO-RACK

33300 LH, 33400 RH - Batwing Compact

**3b** Slide the bag free, off the awning body.

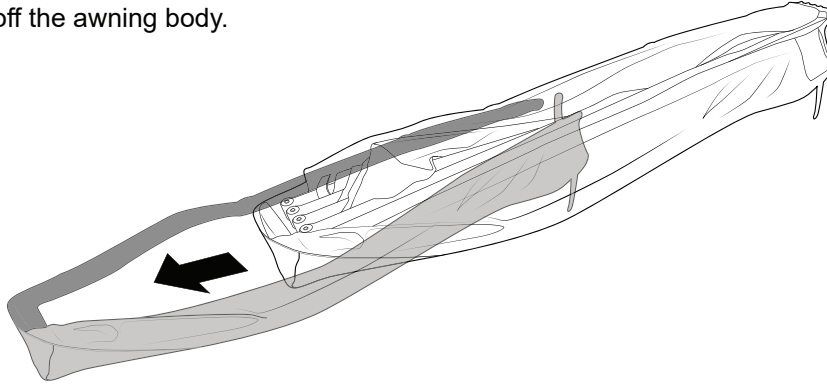

**3c** Slide the new bag in as shown. Be sure correct orientation is used. The matte finish of the PVC bag faces the outside. Replace the plastic plugs with those provided in the new bag kit.

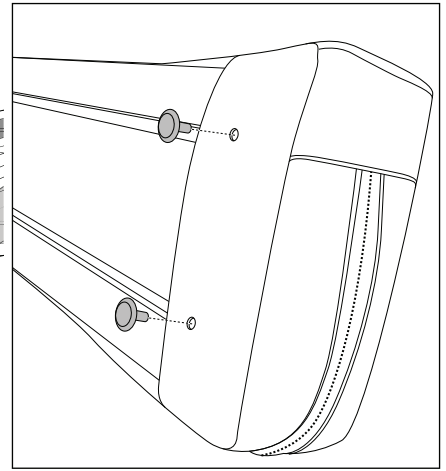
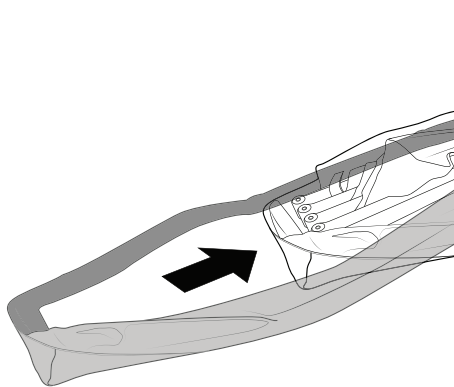
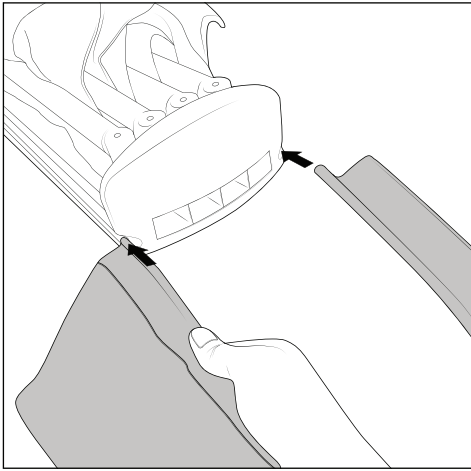

**4**

