



CONTROLLED

RHINO-RACK

RCP21-BK 2005 on Citroën Dispatch, Peugeot Expert, Fiat Scudo SWB.

Important: Please read these instructions carefully prior to installation.
Please refer to your fitting instruction to ensure that the roof racks are installed in the correct locations.
Check the contents of kit before commencing fitment and report any discrepancies

Layout:

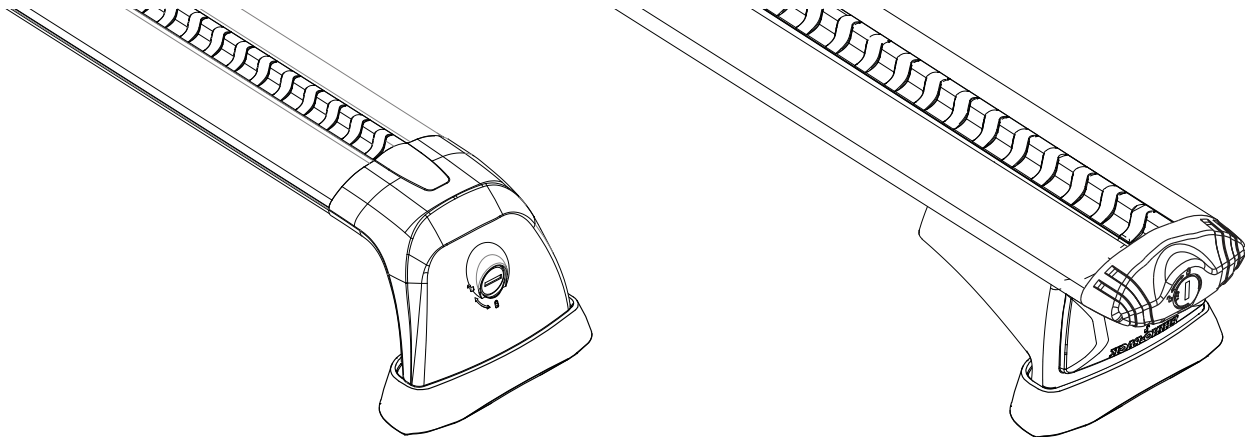

Note: Crossbars and legs sold as separate.

Important Information

1. Check Part No./Kit is correct
2. Read through instruction before installing
3. Fit roof rack accessory
4. Check and recheck all fasteners are secure

Maximum carrying capacity: Two cross bars; 80kg evenly distributed. Three cross bars; 100kg evenly distributed. Note: Be sure to check the Rhino-Rack website to see if you have the latest version of instructions before beginning.

Recommendations:

It is essential that all bolt connections be checked after driving a short distance when you first install your cross bars. Bolt connections should be checked again at regular intervals (probably once a week is enough, depending on road conditions, usage, loads and distances travelled). You should also check the cross bars each time they are re-fitted.

Make sure to fasten your load securely. Please ensure that all loads are evenly distributed and that the centre of gravity is kept as low as possible.

Use only non-stretch fastening ropes or straps. Sensitivity to cross winds, behaviour in curves and braking.

The handling characteristics of the vehicle, changes when you transport a load on the roof. For safety reasons, we recommend you exercise extreme care when transporting wind-resisting loads; special consideration must be taken into account when braking.

Please remove cross bars when putting vehicle through an automatic car wash.

Load Ratings:

Maximum permissible load is 80kg for two cross bars, 100kg for three cross bars (include the weight of the cross bars, 5kg). When cross bars are to be used in off-road conditions, please build a safety factor of 1.5 into this load limit for off-road use, two cross bars = 54kg, three cross bars = 67kg. Although the cross bars are tested and approved to AS1235-2000, Australian road conditions can be much more rigorous. However, increasing the number of cross bars does not increase the vehicles maximum permissible roof loading.

Note for Dealers and Fitters:

It is your responsibility to ensure instructions are given to the end user or client.

Rhino-Rack
3 Pike Street, Rydalmere,
NSW 2116, Australia.
(Ph) (02) 9638 4744
(Fax) (02) 9638 4822

Document No: R1323
Prepared By: Craig Jones
Authorised By: Chris Murty

Fit Time: 30min
Issue No: 01
Issue Date: 10/04/2017

These instructions remain the property of Rhino-Rack Australia Pty. Ltd. and may not be used or changed for any other purpose than intended.



RCP21-BK 2005 on Citroën Dispatch, Peugeot Expert, Fiat Scudo SWB.

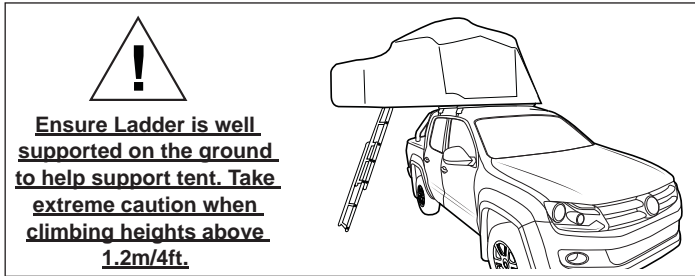
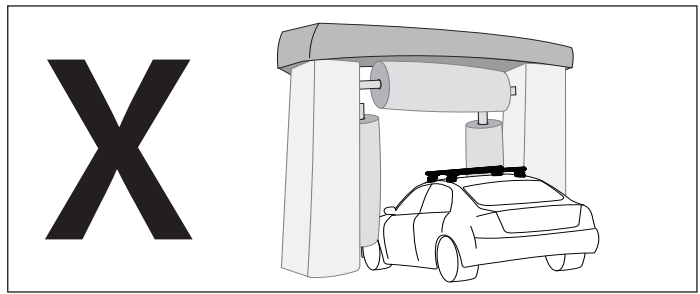
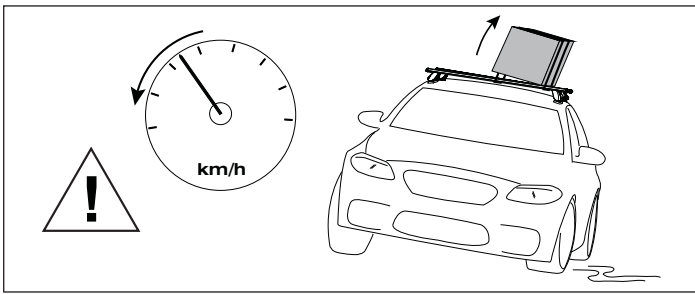
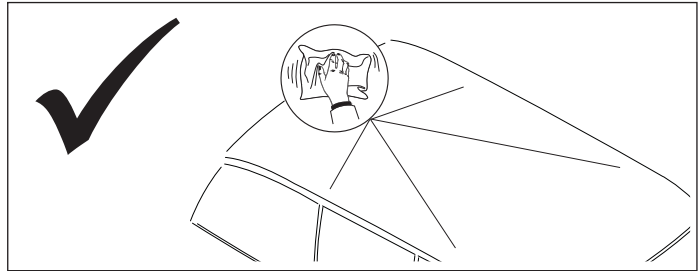
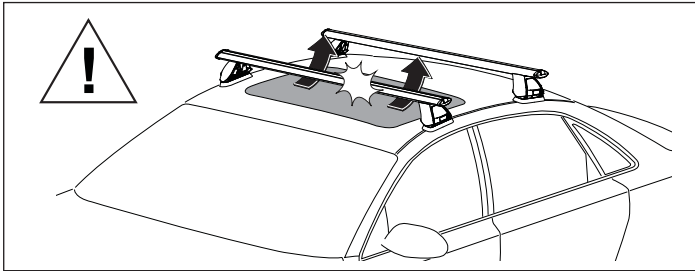
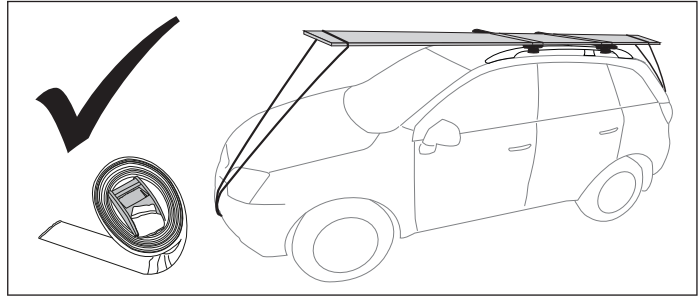
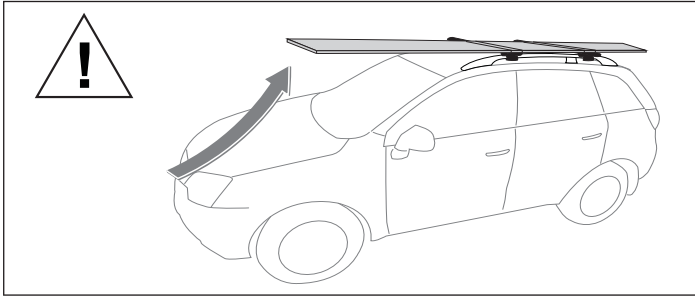

Ensure Ladder is well supported on the ground to help support tent. Take extreme caution when climbing heights above 1.2m/4ft.

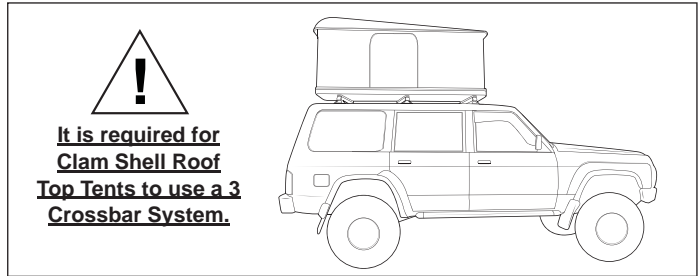

It is required for Clam Shell Roof Top Tents to use a 3 Crossbar System.

When these roof racks are to be used on a vehicle that is driven off sealed roads the maximum load rating must be divided by 1.5. Remember to subtract the weight of the roof racks to determine your maximum permissible load capacity.

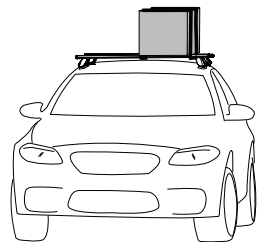

| | | |
|--|----------|---|
| 3 bars 100kg (220lbs) load rating (Urban road) | = | 3 bars 66kg (145lbs) load rating (Off road) |
| 2 Bars 80kg (176lbs) load rating (Urban road) | | 2 Bars 53kg (116 lbs) load rating (Off road) |
| Load rating not taking into account crossbar weight - 5kg | | |

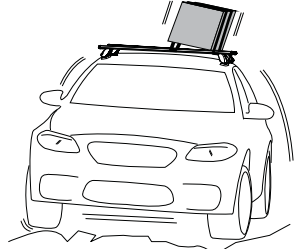

WARNING! Important Load Carrying Instructions

With utility vehicles, the cabin and the canopy move independently. Roof racks and vehicle can be damaged if the item transported is rigidly fixed at points on both the cabin and canopy. Instead, rigidly fix to either the cabin roof racks or the canopy roof racks.

X
NO

✓
YES

✓
YES

Paddle/ Surfboards should be fixed to the front of the vehicle.

✓
YES



RCP21-BK 2005 on Citroën Dispatch, Peugeot Expert, Fiat Scudo SWB.

Parts List

| Item | Component Name | Qty | Part No. |
|------|---------------------------------|-----|----------|
| 1 | M6 x 40mm Torx | 2 | B248 |
| 2 | M6 x 45mm Torx | 2 | B249 |
| 3 | M6 x 32mm Torx | 2 | B246 |
| 4 | M6 Spring Washer | 6 | W004 |
| 5 | M6 x 16mm Flat Washer | 6 | W031 |
| 6 | Pad Cover Plate | 6 | M126 |
| 7 | Spigot Nut | 6 | N042K |
| 8 | Front Left Pad | 1 | M407 |
| 9 | Front Right Pad | 1 | M408 |
| 10 | Middle Left Pad | 1 | M409 |
| 11 | Middle Right Pad | 1 | M410 |
| 12 | Rear Left Pad | 1 | M411 |
| 13 | Rear Right Pad | 1 | M412 |
| 14 | M6 Washer (used on cover plate) | 4 | W003 |
| 15 | T27 Torx Key | 1 | H054 |
| 16 | Instructions | 1 | R1323 |

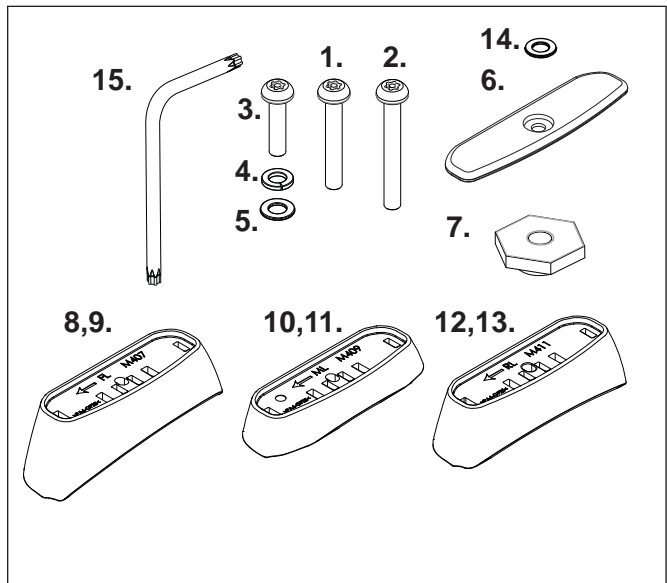

WARNING:

Failure to use the correct length M6 screws will result in vehicle damage. Refer Step 3.

Tools Required: Torx key, provided in kit.

Instructions

1 Short Wheel Base (SWB):

Two or Three cross bar option is available for the SWB van which has five roof mounting brackets. Use only the mounting brackets as indicated below.

Two cross bars; Front & Middle, or Rear & Middle.

Three cross bars; Front, Middle, Rear.

Top view of roof.

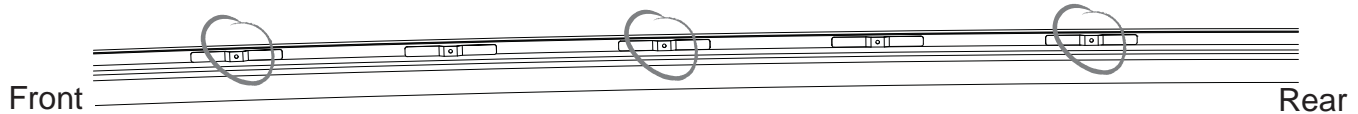

Long Wheel Base (LWB):

Two or Three cross bar option is available for the LWB van which has six roof mounting brackets. Use only the mounting brackets as indicated below.

Two cross bars; Front & either of the two Middle brackets, or Rear & either of the two Middle brackets.

Three cross bars; Front, either of the two Middle and Rear.

Rear



2

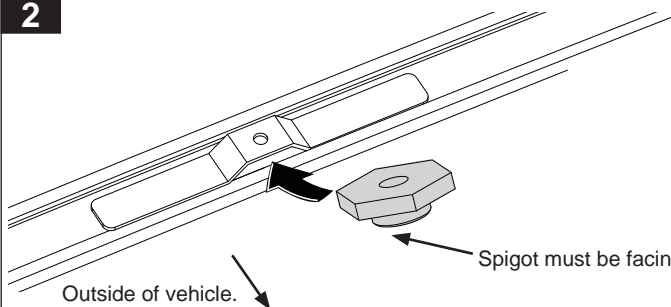

Fit brass hex spigot nut:

Carefully place the brass hex spigot nut (*spigot facing down*) under the raised bracket. Fit from the outer side of the vehicle.

Fit nuts to all brackets that you will be using - refer Step 1 for positioning of two and three cross bars.



RCP21-BK 2005 on Citroën Dispatch, Peugeot Expert, Fiat Scudo SWB.

3 Roof pad orientation:

Pad orientation is identified by the lettering on top. Arrows on pads must face towards front of vehicle when installed.

WARNING: Different length M6 screws are used for the pads.

As shown below, failure to use the correct length screws will result in vehicle damage.

FL = Front Left

ML = Middle Left

RL = Rear Left

FR = Front Right

MR = Middle Right

RR = Rear Right

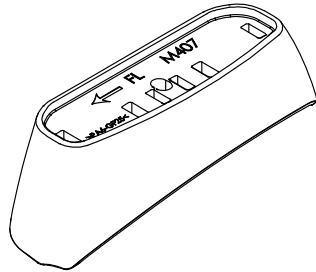

FRONT Left & Right pad.
M6 x 45mm screw.

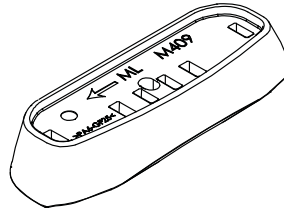

MIDDLE Left & Right pad.
M6 x 32mm screw.

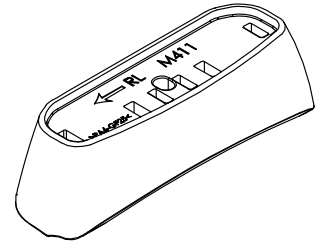

REAR Left & Right pad.
M6 x 40mm screw.



4 Sit pads on roof brackets:

Three cross bar SWB shown. Check each bracket on the roof to make sure the surface is free of dirt. Also check that no lumps of drip check are on the mounting surface of the bracket otherwise the pad will not sit correctly. Remove drip check lumps if necessary.

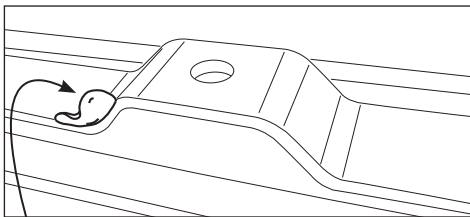

Check for blobs of drip check and remove if necessary.

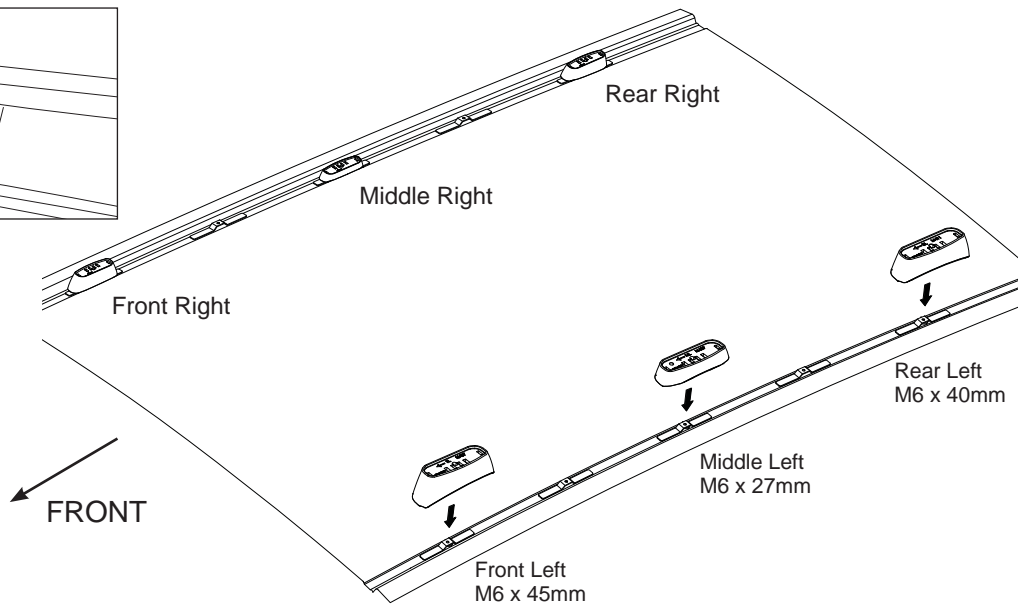

5 Check pads for correct alignment:

Check that each pad is parallel to the opposing side and sitting properly on the roof brackets.

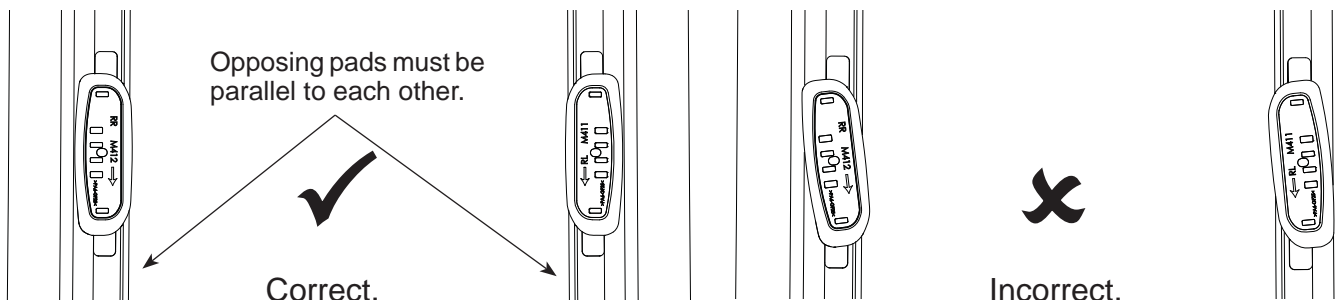



RCP21-BK 2005 on Citroën Dispatch, Peugeot Expert, Fiat Scudo SWB.

6

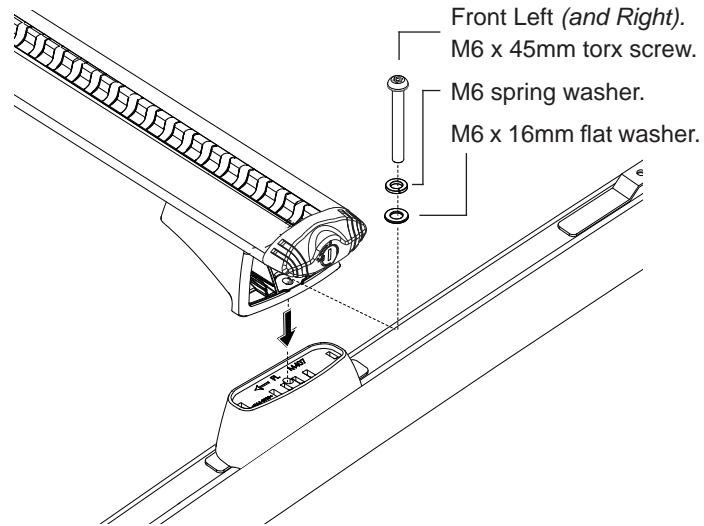

Locate cross bars.

Position the corresponding cross bar on the correct set of roof pads. Correct M6 screw length must be used to avoid roof damage. **Tighten the M6 screws to 3-4 Nm with the allen key provided.**

FRONT Left & Right pad.
M6 x 45mm screw.

MIDDLE Left & Right pad.
M6 x 32mm screw.

REAR Left & Right pad.
M6 x 40mm screw.

7

Fit Cover Plates:

When crossbars are not in use, remove and fit the pad covers in place.

