



CURRENTLYNC[®]

STEERING SYSTEMS

RockJock[®] Professional OffRoad Products presents:

Jeep JK Wrangler RockJock[®] Currentlynyc[®] Steering Components Installation Instructions

Our JK Wrangler Currentlynyc[®] heavy duty steering components very simply install with basic hand tools. Tie Rod includes Steering Stabilizer Bracket Kit. Reversed Drag Link includes knuckle taper bushing.

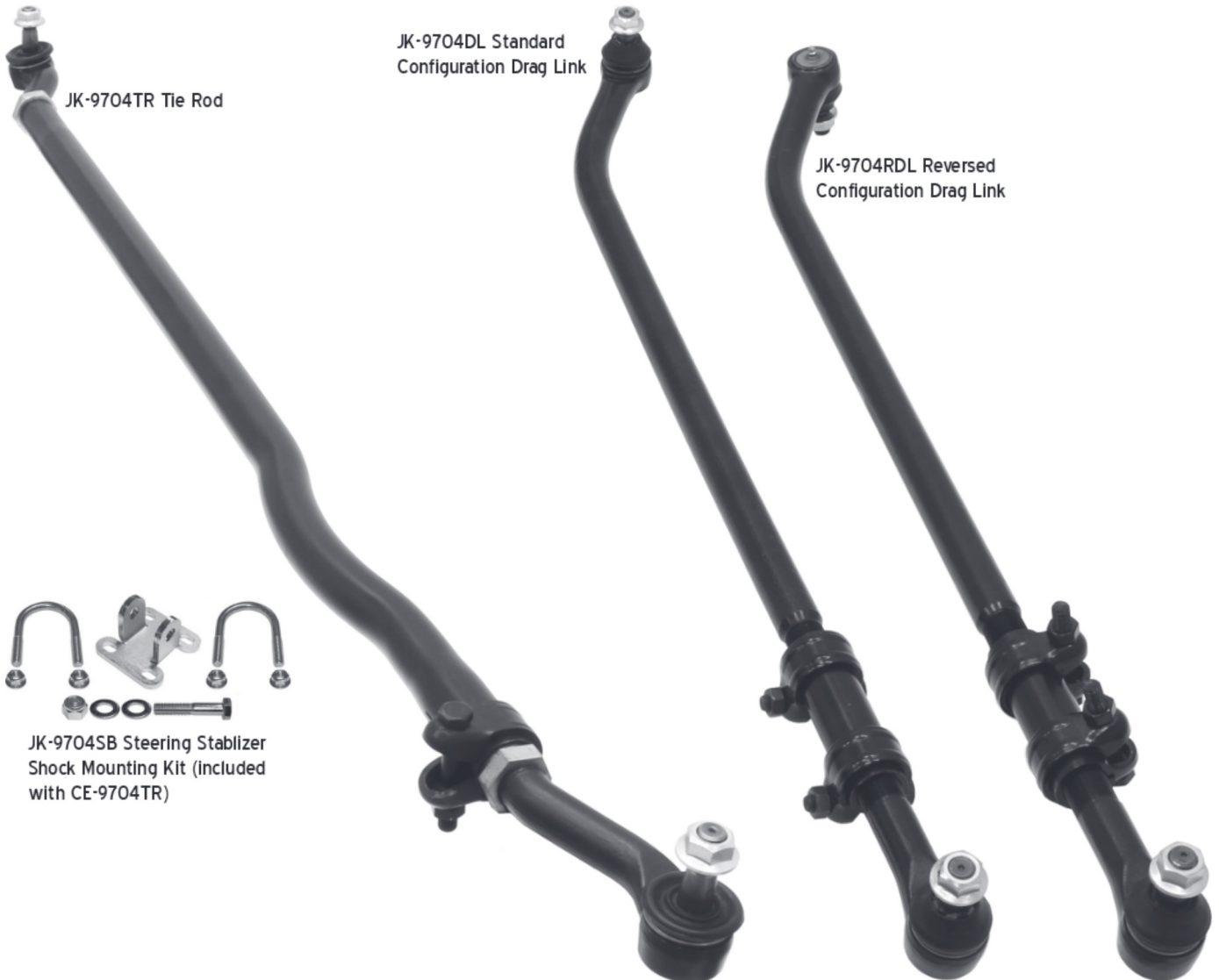

Currie Enterprises / RockJock Professional Off Road Products
382 N. Smith Ave., Corona, Ca. 92880
Ph (714) 528-6957 - F (951) 549-0267
www.rockjock4x4.com





1) After removing the stock tie rod & drag link, if you are using the reversed drag link kit, drill the drag link taper out with a 7/8" drill bit.

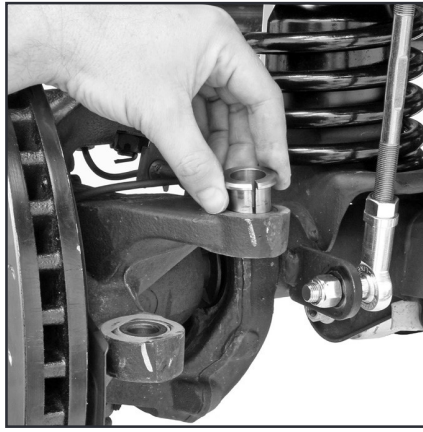

2) In reversed drag link applications only, insert the tapered sleeve into the 7/8" hole.

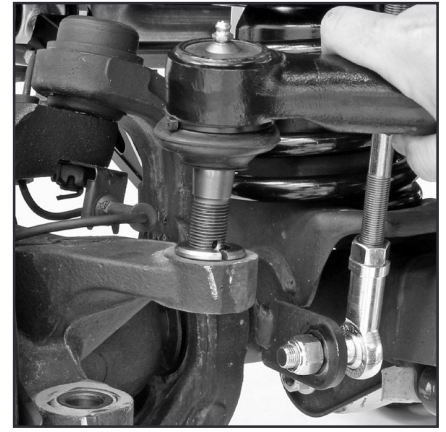

3) In either drag link application, insert the new drag link end into pitman arm and then into the steering arm from either the top or the bottom depending on which kit you are installing.

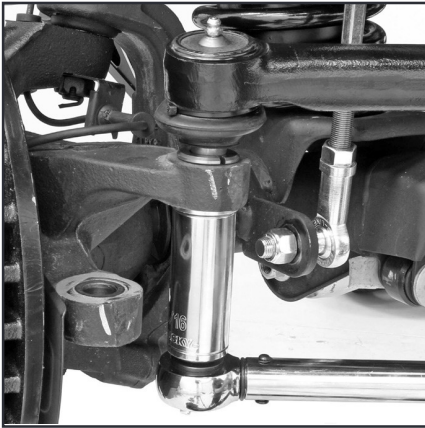

4) Install the supplied nuts at both ends of the drag link and torque to 80 ft. lbs.



5) Insert the new tie rod ends into the knuckles and install the supplied nuts.



6) Torque both nuts to 80 ft. lbs.

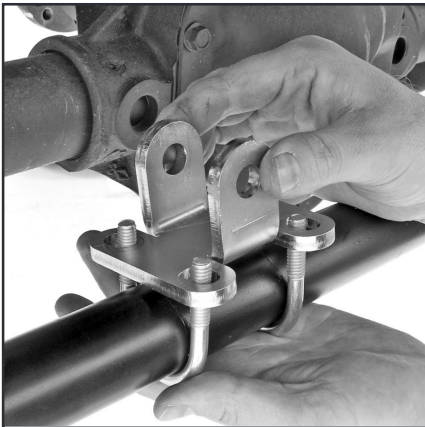

7) Assemble the supplied steering stabilizer kit onto the tie rod as shown.



8) Reinstall the end of the factory shock into the bracket. To adjust the shock properly, turn the wheels all the way to the right to the lock and hold them there. Completely compress the stabilizer shock, pull it back out 1/8" and then clamp it down onto the tie rod. Torque the u-bolt nuts to 25 ft. lbs.



9) Torque the stabilizer shock bolt to 50 ft. lbs.

** Note: the diameter of some steering stabilizer shocks may require the length of the u-bolt threads to be trimmed! **



Currie Enterprises / RockJock Professional Off Road Products

382 N. Smith Ave., Corona, Ca. 92880

Ph (714) 528-6957 - F (951) 549-0267

www.rockjock4x4.com



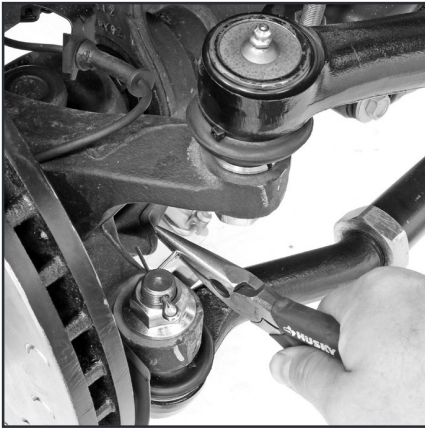

10) Install cotter pins on all four tie rod ends.

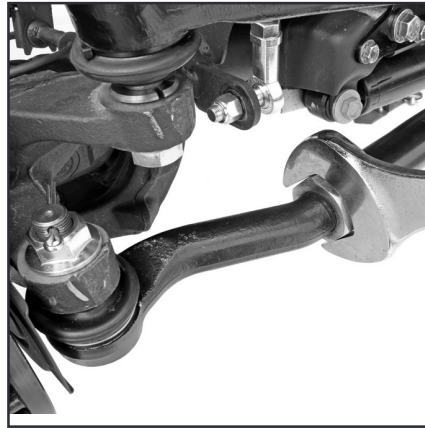

11) Make sure the passenger side tie rod end jam nut is tight!



12) An alignment shop can use the double adjuster at the driver's side of the tie rod and the pitman arm end of the drag link to center your steering wheel and realign your steering.

** Don't forget to grease all tie rod ends before driving your vehicle! **

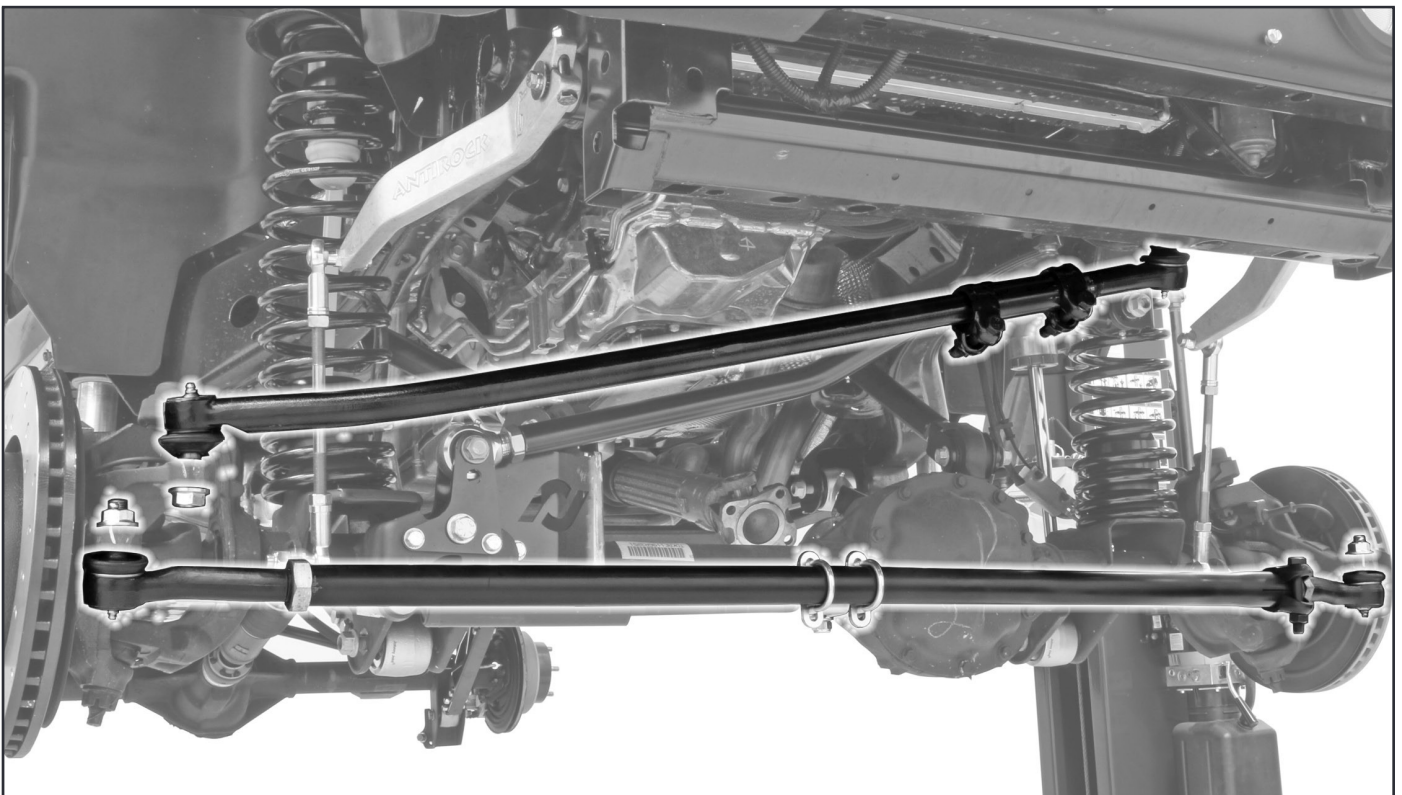

Parts Department

JK-9704DL-1	Drag Link End	JK-9704TR-1	Driver's Side Tie Rod End
JK-9704DL-2	Standard Drag Link Bar	JK-9704TR-2	Passenger's Side Tie Rod End
JK-9704DL-3	Drag Link Adjuster Sleeve	JK-9704TR-3	Tie Rod Tube
JK-9704DL-4	Drag Link Adjuster Clamp	JK-9704TR-4	Tie Rod Adjuster
JK-9704DL-R	Reversed Drag Link Bar	JK-9704TR-5	Tie Rod Adjuster Clamp
JK-9704RDLB	Reversed Drag Link Tapered Sleeve	JK-9704TR-6	Tie Rod End Jam Nut



Currie Enterprises / RockJock Professional Off Road Products
 382 N. Smith Ave., Corona, Ca. 92880
 Ph (714) 528-6957 - F (951) 549-0267
www.rockjock4x4.com

