



INSTALLATION INSTRUCTIONS

Product: Rear Adjustable Coil Over Spacer ACOS™
Part Number: 2571

Applications: Wrangler JL 2018

517-278-1226 • jks@ridefox.com • www.jksmfg.com
491 W. Garfield Avenue, Coldwater, MI 49036

Welcome

CONGRATULATIONS on your purchase of a new JKS ACOS™ system! At JKS Manufacturing, we are committed to providing you with the best products available and your satisfaction is our first priority.

PLEASE READ these Installation Instructions carefully, and save them for future reference, as they contain important installation and maintenance information.

Before You Begin

- Familiarize yourself with the supplied parts as illustrated in the column to the far right.
- Thoroughly read all procedures to ensure you have the tools and experience necessary to complete this installation.
- If you are not completely comfortable with any of the procedures described on the following pages, do not attempt this installation. Contact the JKS Technical Department at 517-278-1226 to locate a qualified installation specialist in your area.

Important

MOST VEHICLES REQUIRE additional parts or modifications to accommodate the immediate increase in ride height provided by the ACOS™ system.

DO NOT EXCEED maximum range of adjustment – see illustration on page 3.

Tools Required

- Hydraulic Floor Jack and Jack Stands
- Metric/Standard Socket Wrench Set
- 1/4" Allen Wrench
- Die Grinder with Cut-Off Wheel (or reciprocating saw)
- File or de-burring Tool
- Tape Measure
- Spray Lubricant (WD-40 or similar)
- Anti-Seize Lubricant
- Satin Black Spray Paint
- Coil Spring Compressor *
- 3/8" Drill bit
- Drill
- Factory Service Manual (recommended)

** Asterisk denotes tools that are not required for some applications. Thoroughly read instructions first to determine which tools will be required for your application.*

Parts

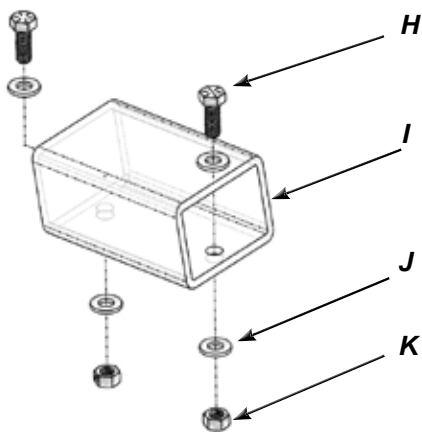
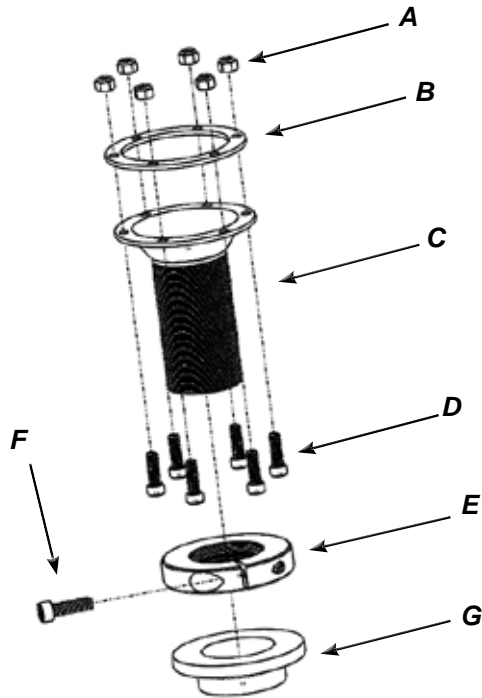

	Description	QTY
A	5/16-18 Nylock Nut	12
B	Reinforcement Ring	2
C	Cone Adapter Plate	2
D	5/16-18 x 1" Cap Screw	12
E	Adjuster Ring	2
F	3/8-16 x 1-1/4" Cap Screw	2
G	Isolator Pad	2
H	5/16-18 X 7/8" Hex Bolt	4
I	Bump Stop Block	2
J	SAE 5/16 Washer	8
K	5/16-18 Prevailing Torque Nut	4

Installation

- 1. REMOVE REAR COIL SPRINGS
 - Park the vehicle on a clean, flat surface and block the front wheels for safety.
 - Raise the rear of the vehicle with a hydraulic jack and support the frame with jack stands at the rear portion of each frame rail.
 - Remove the wheels.
 - Remove the bolts holding the brake lines to the frame.



- Remove the sway bar links from the axle and sway bar.



- Remove the rear inner fender liners by removing the 3 bolts to gain access to the upper shock bolt



- Support the axle with a jack under the center of the differential and remove the shocks from the frame and axle and save hardware



- Lower the axle enough to remove the factory springs. Make sure there is adequate slack on all brake lines.

□ 2. PREPARE UPPER SPRING MOUNT

- Using a paint marker, trace the circumference of the OE isolator pad.



- Remove the rubber isolator pad from the upper coil spring mount on the chassis.
- Locate the small hole in the upper spring mount that was previously concealed by the rubber isolator pad.

- Position the flange end (concave) of the Cone Adapter Plate (C) over the center portion (convex) of the upper spring mount.
- Rotate the Cone adapter plate so that one of the holes lines up with the factory hole in the factory spring mount, while keeping the Cone Adapter plate concentric within the traced circle of the OE Isolator Pad.

Note: The Cone Adapter Plate (C) will be slightly bias towards the factory hole in the factory upper spring mount. You can also use a 5/16-18 x 1" Cap Screw (D) to help keep the Cone Adapter Plate (C) aligned with the factory hole.



- Using the Cone Adapter Plate (C) as a template, accurately mark the 5 remaining hole locations on the upper spring mount.

Hint: A transfer punch or similar tool is useful for marking hole locations.

- Remove the Cone Adapter Plate (C) and drill a pilot hole at each marked locations using a 1/4" drill bit. Enlarge each hole with a 3/8" drill bit.



- Paint any exposed metal on the upper spring mount to prevent corrosion.

□ 3. INSTALL ACOS™ ON FRAME

- Place Reinforcement Ring (B) on top of the upper spring mount and align with drilled holes.
- Reposition the Cone Adapter Plate (A) of ACOS™ over the center portion of the upper spring mount so that all six mounting holes align.
- Insert a 5/16-18 x 1" (D) through each mounting hole.

Hint: Bolts must be inserted from the bottom through the Cone Adapter Plate, Upper coil spring mount, and Reinforcement Ring.

- Loosely thread a 5/16" Nylock Nut (A) onto each 5/16" x 1" Bolts (D)



- Once all 6 bolts have been installed, tighten the 5/16" Nylock Nuts (A) to 40 ft-lbs using a torque wrench.

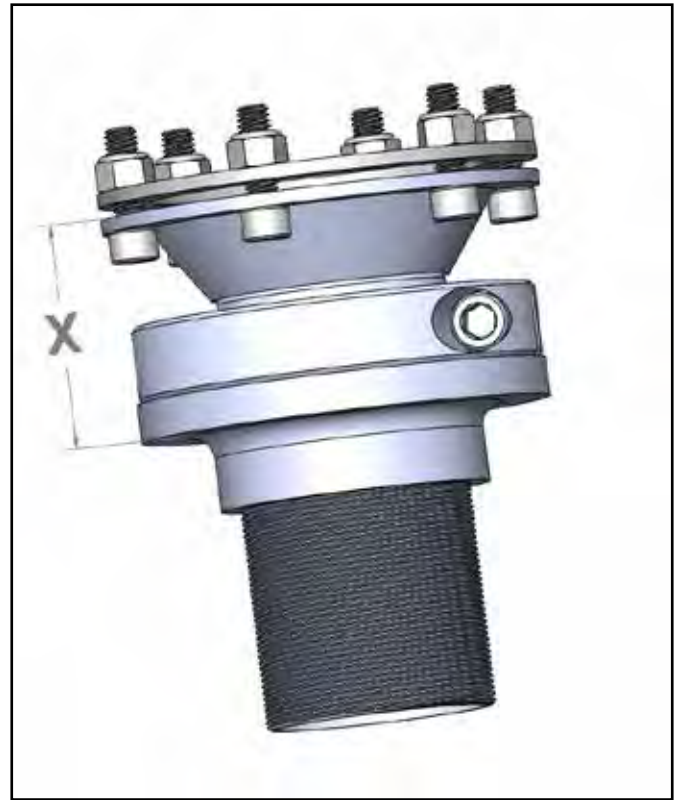

WARNING

**DO NOT EXCEED
MAXIMUM RANGE OF ADJUSTMENT**

Adjustment Range*

Minimum: 2" (2.0 in.)

Maximum: 4" (4.0 in.)

X" – 1/2" = RIDE HEIGHT *

* Represents increase in ride height over OE suspension

- Rotate Adjuster Ring (B) to desired position and tighten the recessed 5/16" x 1-1/4" Cap Bolt (F) to lock in place.

Note: For 2" lifts, it is not required to remove any material from cone adapter plate

□ 4. SET ADJUSTER RING FOR DESIRED RIDE HEIGHT

- Apply spray lubricant to threaded portion of Cone Adapter Plate (C)
- Install Adjuster Ring (E) by threading it onto the Cone Adapter Plate (C)
- Slide Isolator Pad (G) onto Cone Adapter Plate (C) until it is flush with Adjuster Ring (B)

Important: Vehicle Ride height is determined by measuring the distance between the top of the Cone adapter Plate and the bottom of the Isolator Pad, then Subtracting 1/2" (0.50 in.)

❑ 5. INSTALL BUMP STOP BLOCK ONTO AXLE

- A 2 inch bump stop (I) is included in this kit. For lifts above 2 inches, it will be required to use an alternative bump stop block to meet your lifts requirements.
- Install bump stop blocks (I) onto axle in OEM holes as shown below using (2) 5/6-18 x 7/8 bolt, (4) SAE 5/16 washer and (2) 5/16-18 prevailing torque nut. The block should be angled toward the front of the vehicle.



8. RE-INSTALL REAR COIL SPRINGS

- Re-install the rear coil springs per the factory service manual instructions. **HINT:** A coil spring compressor is useful for installation
- Also Re-install any of the components that were removed during the REMOVE REAR COIL SPRINGS (1) section of this installation.

Operation

Ride Height Adjustments

Future ride height and bump shock adjustments should be made with **NO LOAD** on the rear coil springs, and the suspension at **FULL DROOP**.

NEVER TURN Adjuster Ring (G) while under tension and **ALWAYS APPLY SPRAY LUBRICANT** to threads of Threaded Tube (A) before adjusting.

Maintenance

Regular cleaning with pressurized water is recommended to maximize ease of operation and reliability.

©2018 JKS Manufacturing, Inc
Revision Date 11/29/2018