

AmFib Snorkel; JL Patent Pending

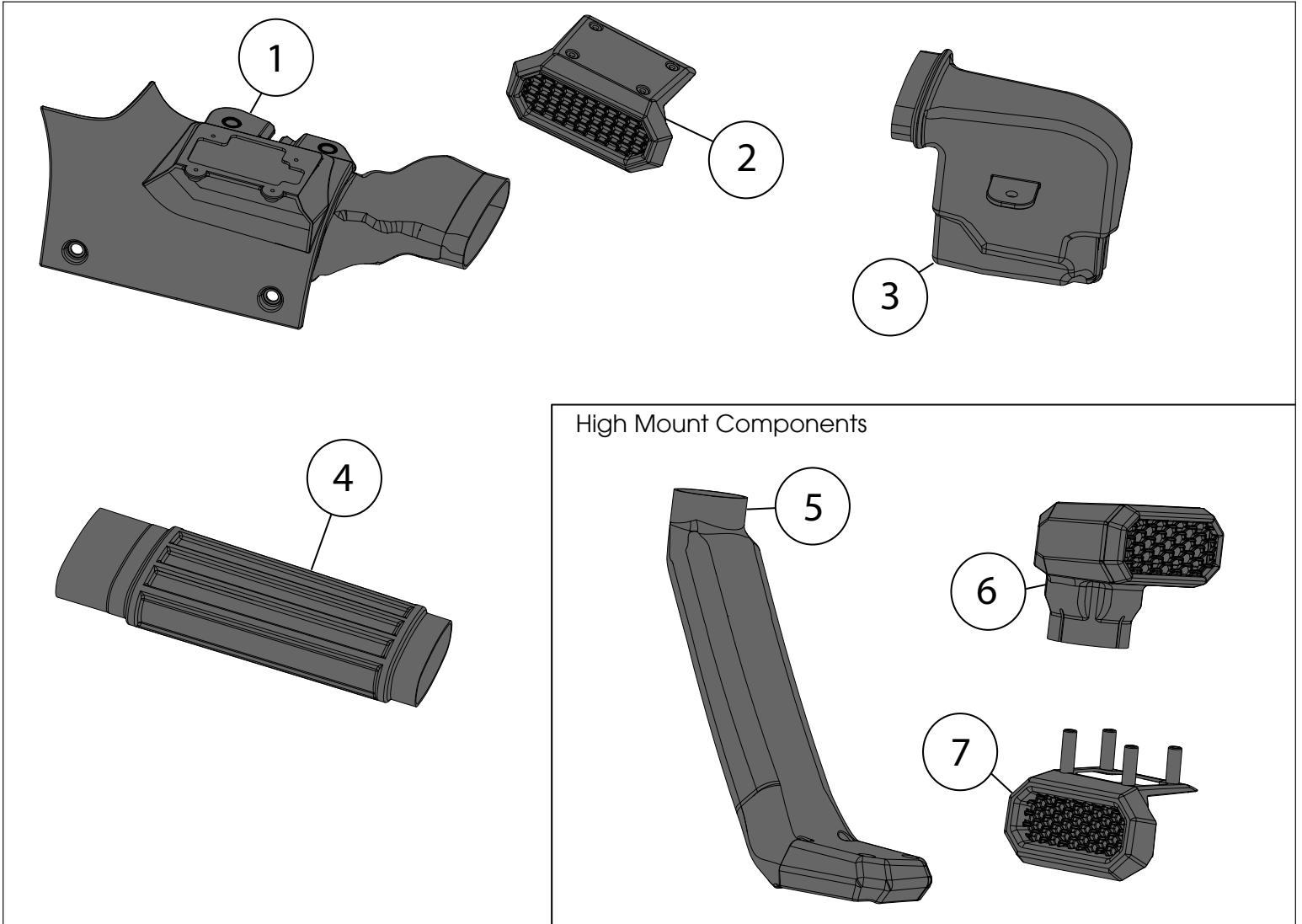

Components

1. Snorkel Inlet	(1)	5. High Mount Tube	(1)
2. Low Mount Cover	(1)	6. Ram Inlet	(1)
3. Air Box Adapter	(1)	7. High Mount Cover	(1)
4. Air Channel	(1)		

OMIX-ADA® TECHNICAL SUPPORT

PHONE: M-F 8am - 5pm EST 1-800-449-6649

FOR WARRANTY OR TECH CONCERNS EMAIL: webmaster@omixsupport.com

ATTN: STATE OF CALIFORNIA CONSUMERS

⚠ WARNING: Cancer and Reproductive Harm - www.P65Warnings.ca.gov.

AmFib Snorkel; JL Patent Pending

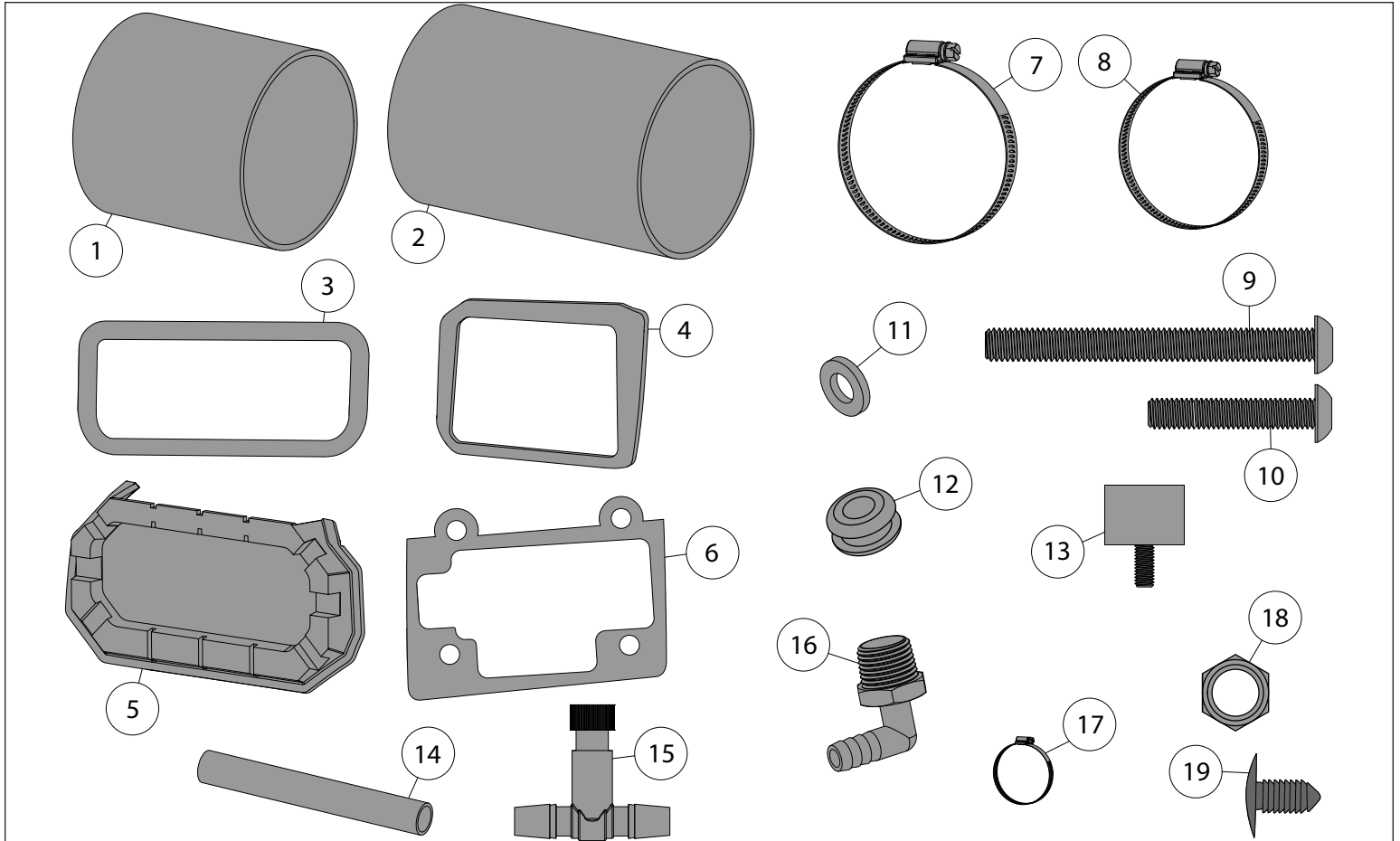

Hardware

- | | | | |
|-------------------------------|-----|-----------------------|-----|
| 1. Short Coupler | (1) | 11. M6 Plastic Washer | (8) |
| 2. Long Coupler | (1) | 12. Push-In Grommet | (1) |
| 3. Air Box Gasket | (1) | 13. Rubber Bumper | (1) |
| 4. Top Gasket | (1) | 14. Silicone Tube | (1) |
| 5. Molded Gasket | (1) | 15. Drain Valve | (1) |
| 6. Adhesive Backed Gasket | (1) | 16. Nylon Fitting | (1) |
| 7. 5in Clamp | (4) | 17. Fitting Nut | (1) |
| 8. 3in Clamp | (1) | 18. 1in Clamp | (2) |
| 9. Long M6 Button Head Bolt | (4) | 19. Push Rivets | (4) |
| 10. Short M6 Button Head Bolt | (4) | | |

OMIX-ADA® TECHNICAL SUPPORT

PHONE: M-F 8am - 5pm EST 1-800-449-6649

FOR WARRANTY OR TECH CONCERNS EMAIL: webmaster@omixsupport.com

ATTN: STATE OF CALIFORNIA CONSUMERS

⚠ WARNING: Cancer and Reproductive Harm - www.P65Warnings.ca.gov.

AmFib Snorkel; JL Patent Pending

1. Lift hood. Remove factory grille. Remove right side radiator closure panel rod.

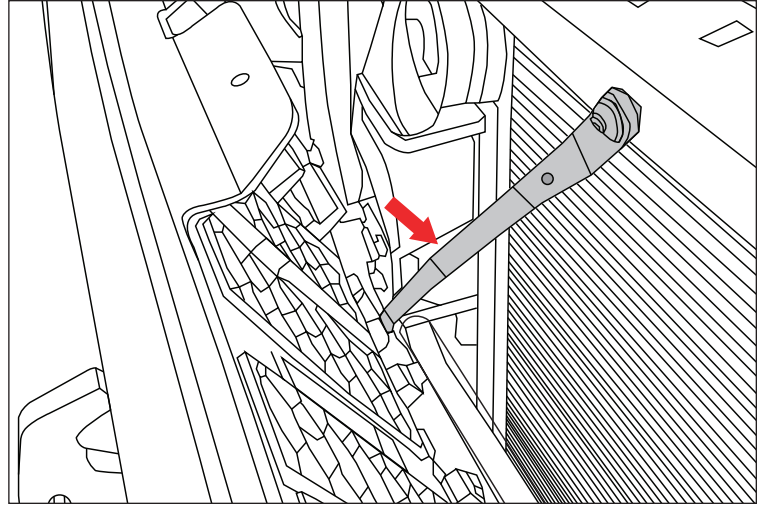

2. Disconnect tube(s) from air intake tube by pressing in the tab on the connector. Gently pull connector away from air intake tube.

NOTICE Location of tube(s) will vary depending on engine.

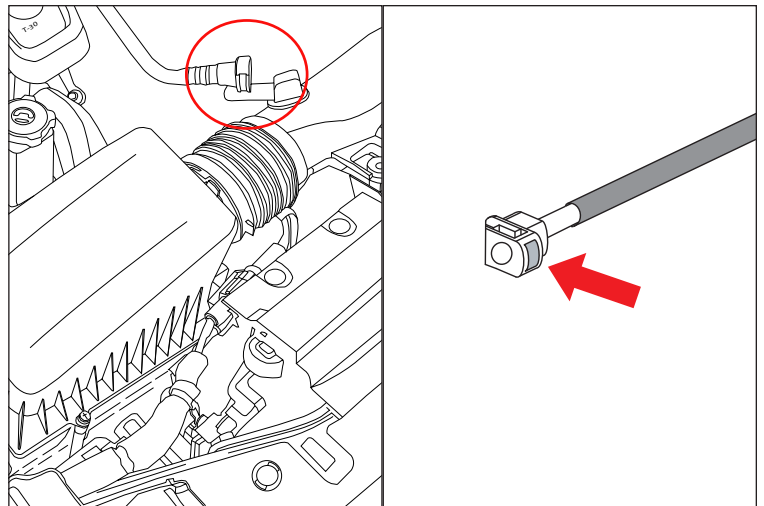

3. Loosen the two hose clamps. Remove the two 10mm bolts. Lift up air intake tube. Unplug the IAT Sensor. Remove air intake tube. Hardware will be reused.

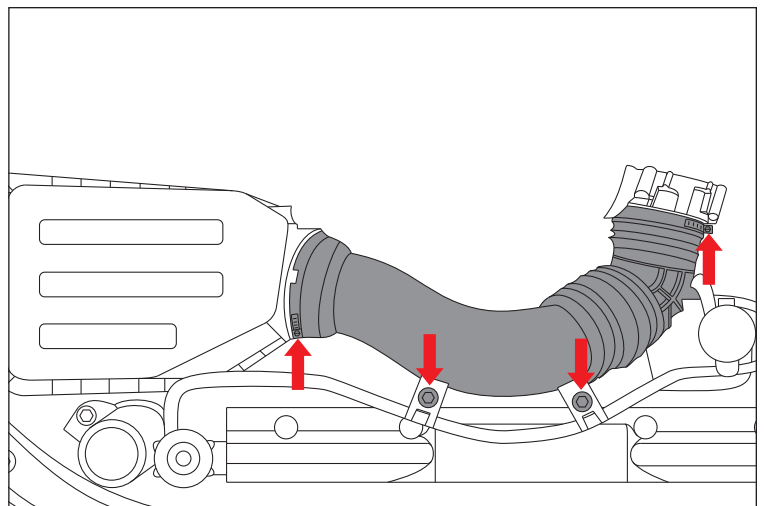

AmFib Snorkel; JL Patent Pending

4. Remove OE bolt securing factory air filter box to fender. There are two rubber grommets still holding the bottom of the factory air filter box to the vehicle. Disengage the rubber grommets by lifting up on factory air filter box.

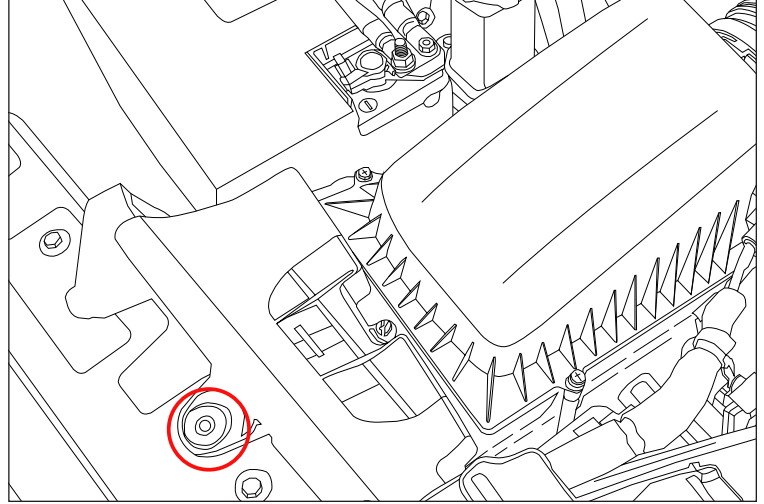

5. Remove ambient air duct by unscrewing two bolts located behind the radiator support bar. Lift ambient air duct out of engine bay.

NOTICE If ambient air duct gets stuck between the radiator and radiator support, a firm pull will release it.

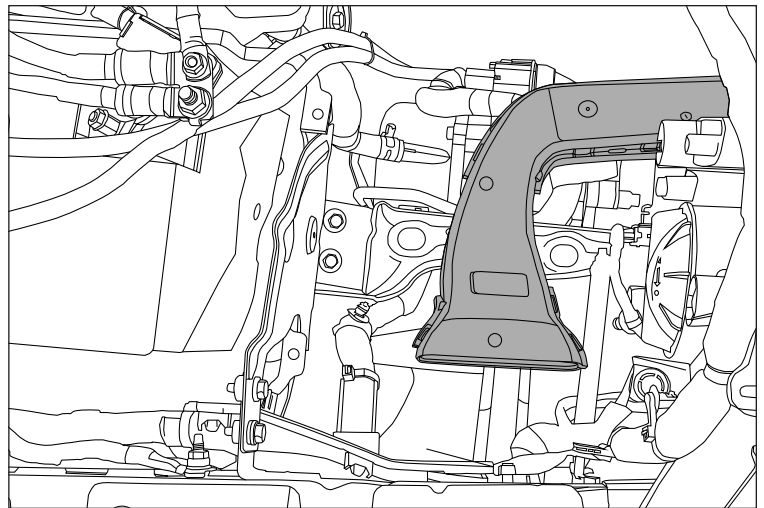

6. Remove radio antenna. Remove right side cowl side panel. Factory hardware is reused.

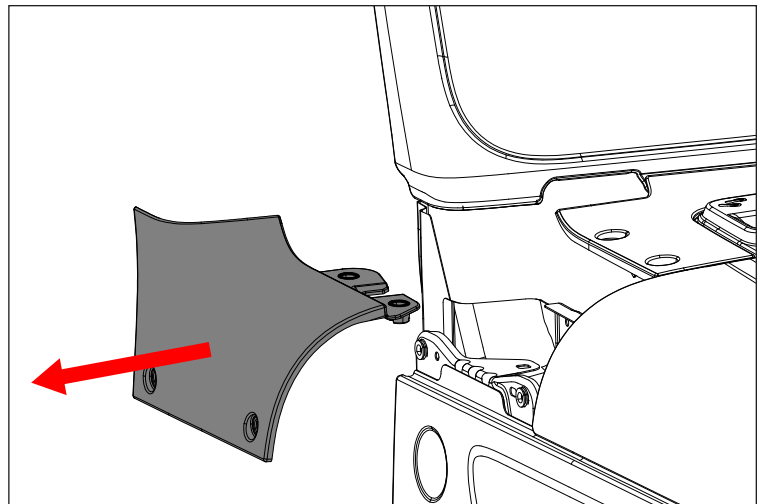

AmFib Snorkel; JL Patent Pending

7. Remove fender to cowl foam piece.

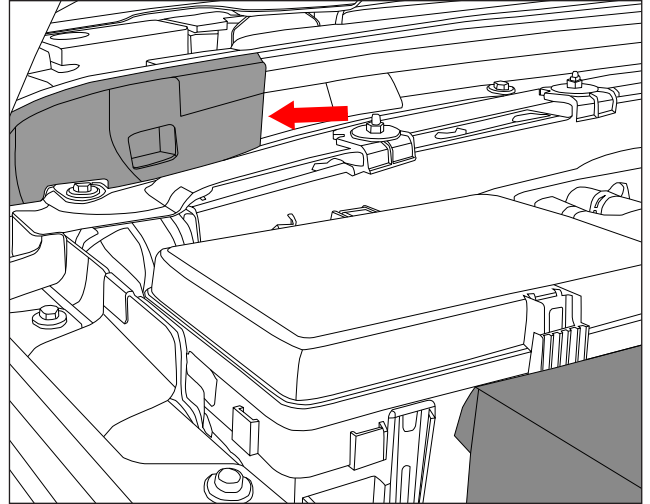

8. Remove bolt on cowl plenum lower panel. This bolt will not be reused.

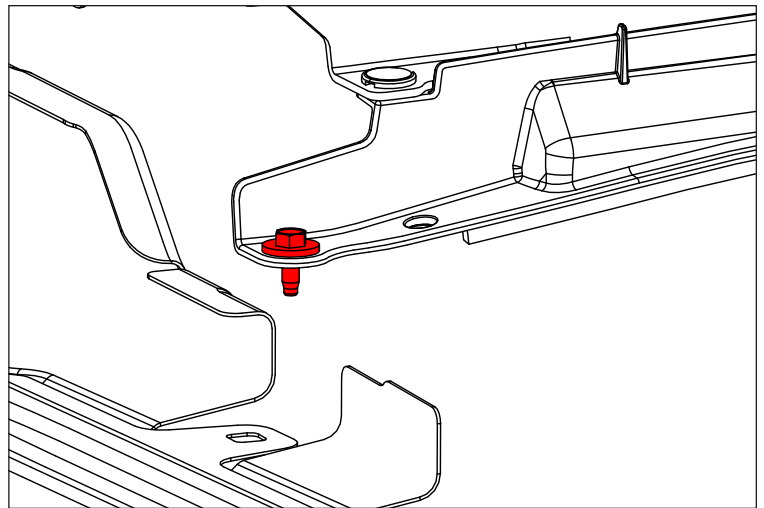

9. Cut cowl plenum lower panel as shown.

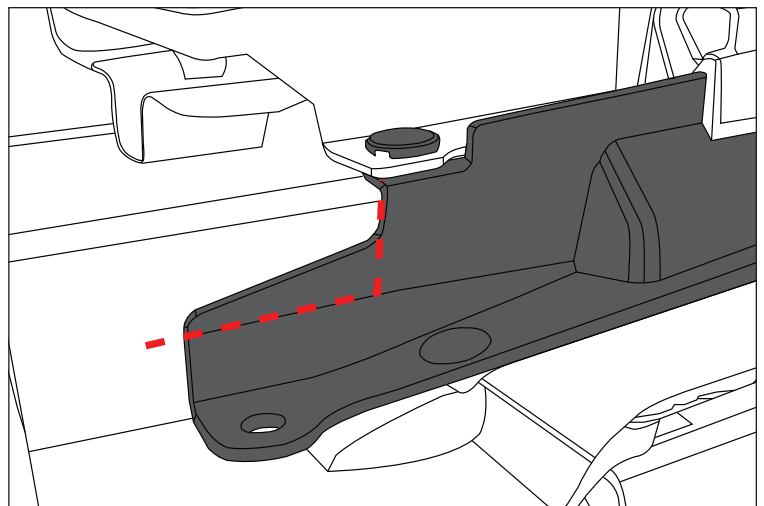

AmFib Snorkel; JL Patent Pending

10. Attach Snorkel Inlet reusing factory hardware.

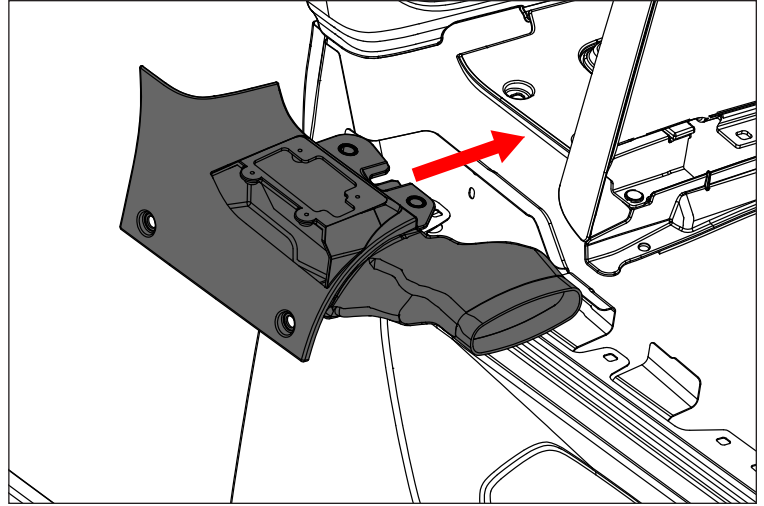

11. Remove bolt securing splash guard to factory air filter box. Using a small flat head screw driver, disengage tabs, and separate splash guard from factory air filter box.

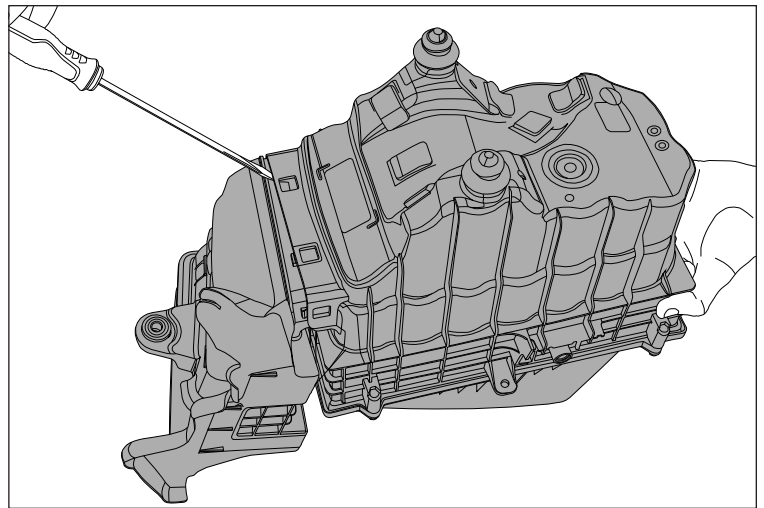

12. Open factory air filter box. Remove engine air filter. Plug holes on the bottom of air filter box using push rivets. Seal holes around push rivets by using silicone.

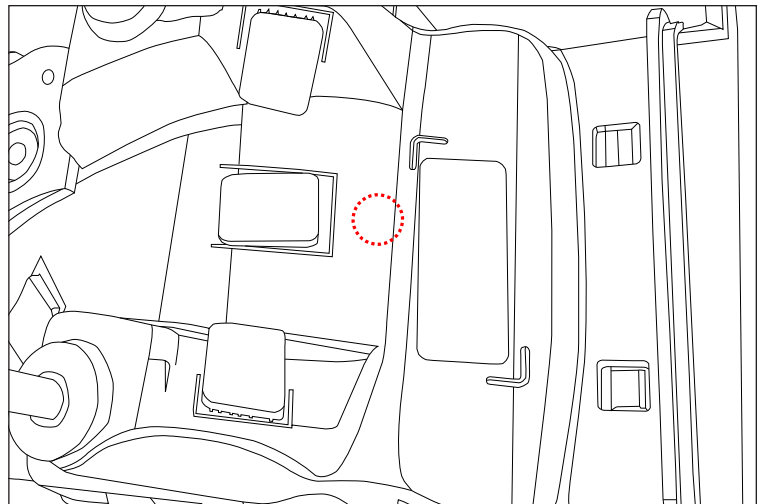

13. Mark and drill hole using a 5/8in (16mm) drill bit for Nylon Fitting on the bottom of factory air filter box.

AmFib Snorkel; JL Patent Pending

14. Attach Nylon Fitting using Fitting Nut. With 1in Clamps, attach Silicone Tube to Nylon Fitting and Drain Valve. Reinstall engine air filter and close factory air filter box.

NOTICE Use silicone to seal any holes around Nylon Fitting.

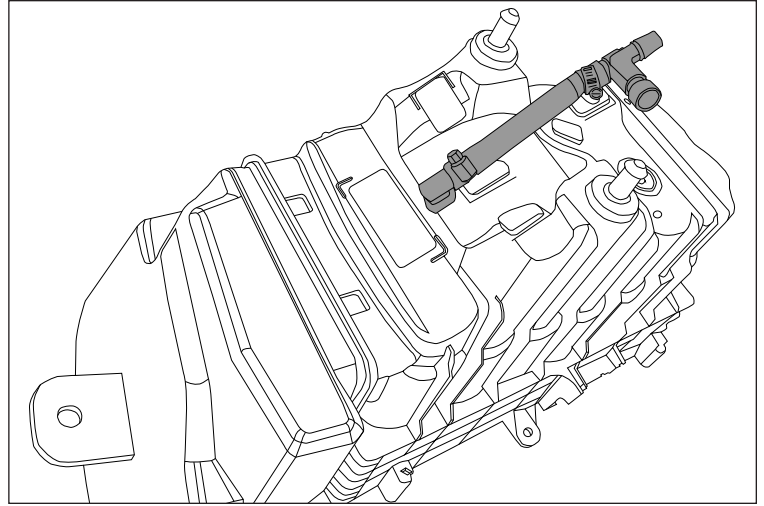

15. Attach Air Box Gasket and Push-in Grommet to Air Box Adaptor.

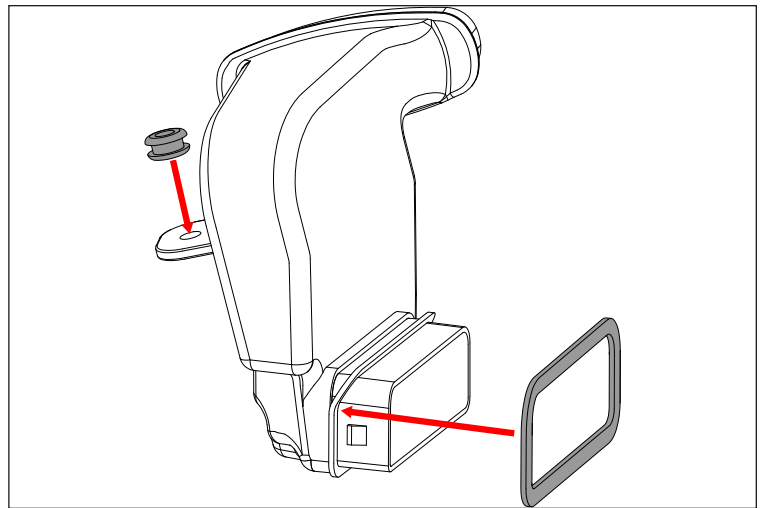

16. Attach Air Box Adaptor to factory air filter box.

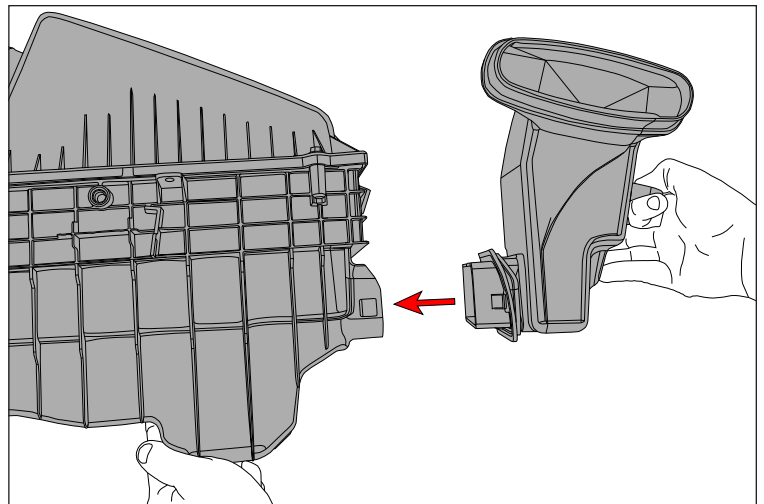

AmFib Snorkel; JL Patent Pending

17. Reusing OE rubber grommets, reattach factory air filter box to vehicle. Loosely attach Air Box Adaptor reusing OE hardware to fender. Reattach air intake tube to engine and factory air filter box using OE hardware. Reconnect all sensors and vacuum tube(s) to air intake tube.

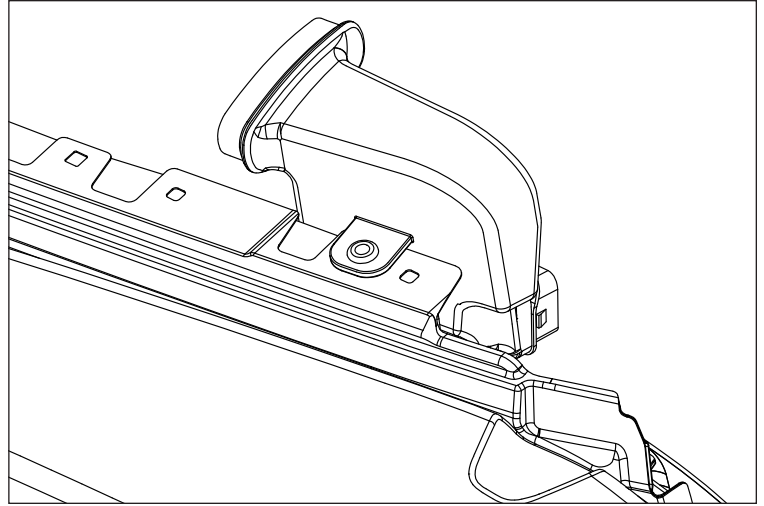

18. Slide Short and Long Couplers on to Air Channel. Using soapy water can make it easier to install Couplers.

NOTICE The indicator marker on the Air Channel points downward when installed on vehicle (circled in image).

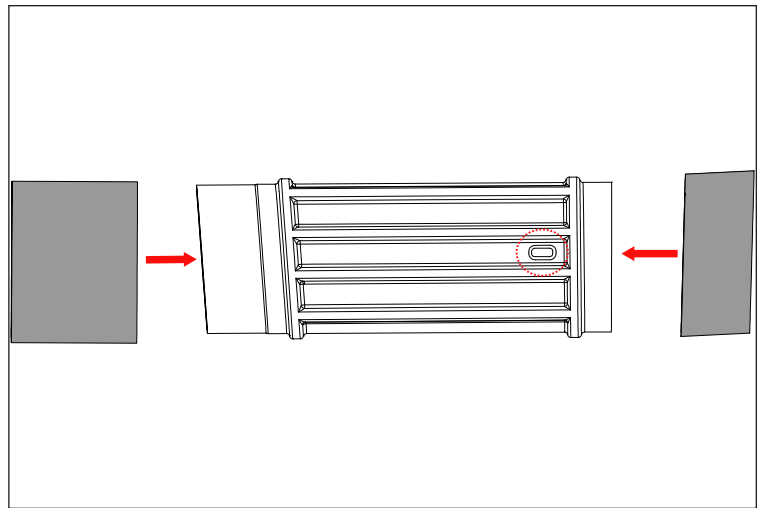

19. Position 5in Clamps on Couplers. Attach Couplers and Air Channel to Snorkel Inlet and Air Box Adaptor.

Short Coupler attaches to Air Box Adaptor and Long Coupler attaches to Snorkel Inlet.

NOTICE

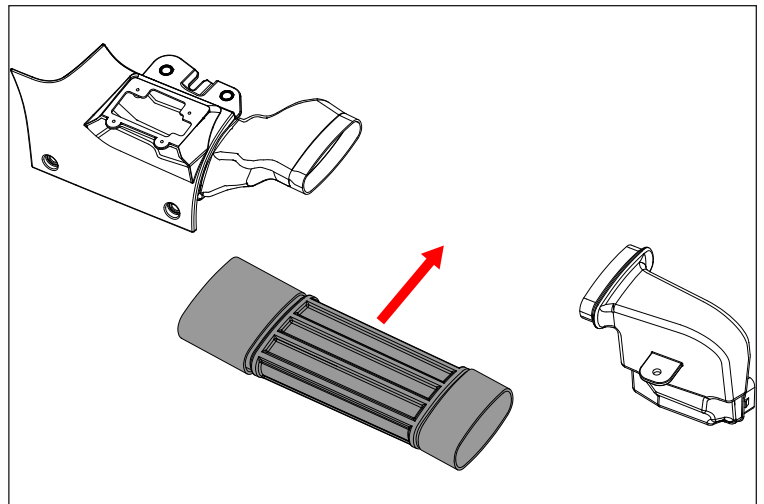

AmFib Snorkel; JL Patent Pending

20. Tighten 5in Clamps. Reattach radiator support bar and grille. Tighten all loose hardware.

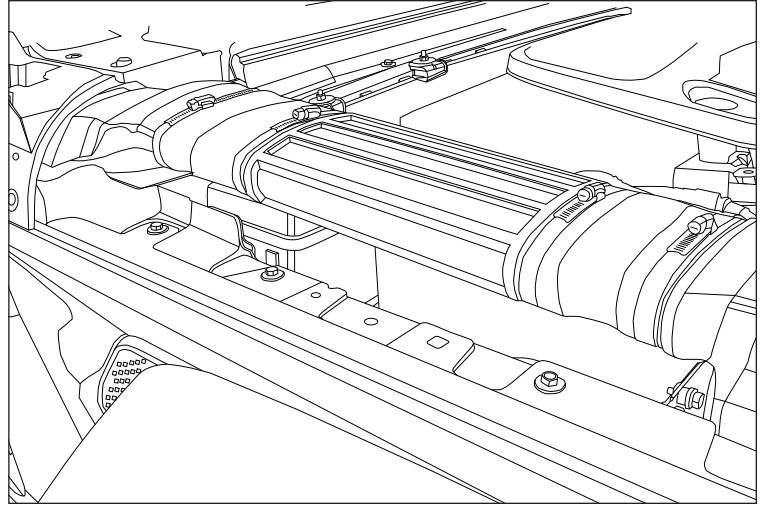

NOTICE If installing High Mount, skip to step 22.

21. Close hood. Using Short M6 Button Head Bolts and Plastic Washers, attach Low Mount Cover.

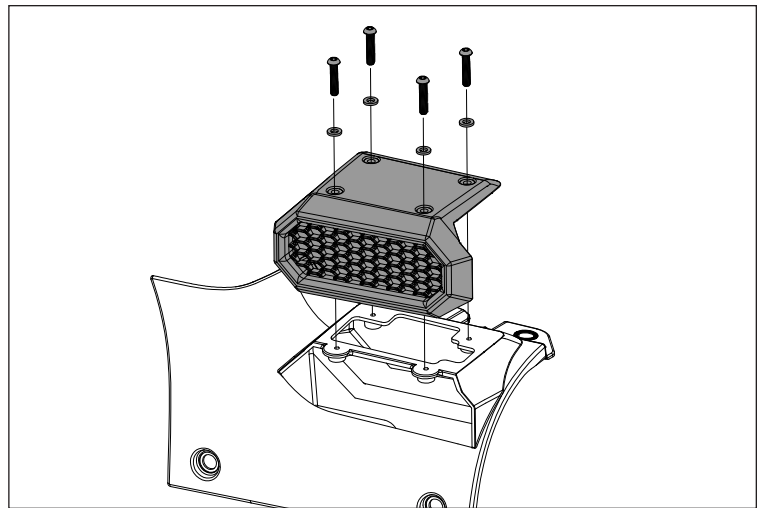

22. Close hood. Remove paper backing from Adhesive Backed Gasket. Align and attach adhesive side to Snorkel Inlet.

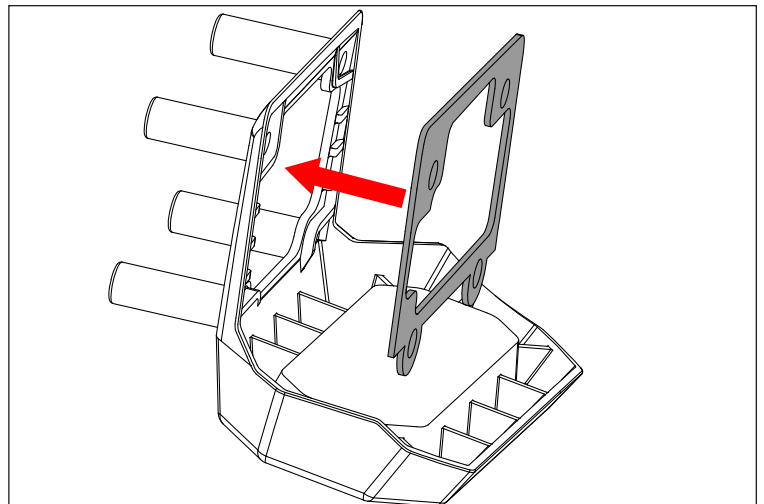

AmFib Snorkel; JL Patent Pending

23. Align Molded Gasket to High Mount Cover. Place Top Gasket on High Mount Cover.

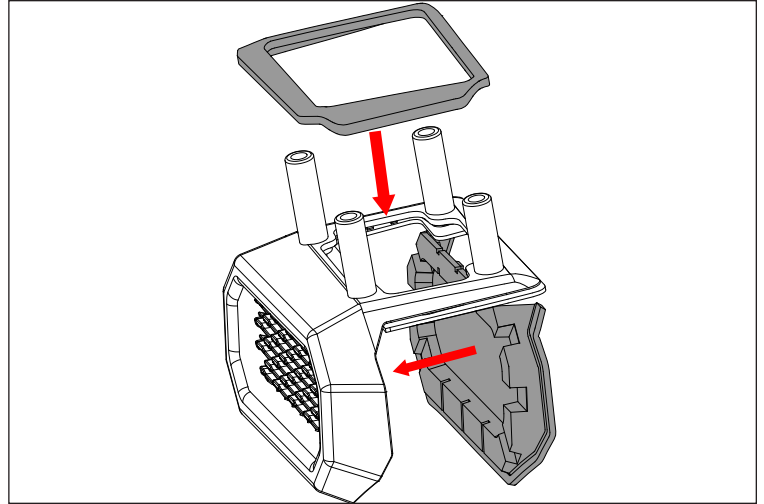

24. Screw Rubber Bumper to High Mount Tube.

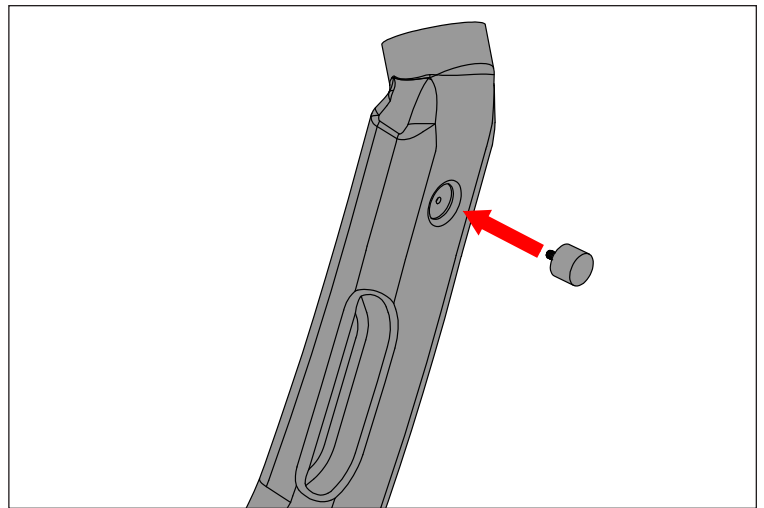

25. Align High Mount Tube to High Mount Cover and Snorkel Inlet. Using Long M6 Button Head Bolts and M6 Plastic Washers, attach High Mount Cover and High Mount Tube to Snorkel Inlet.

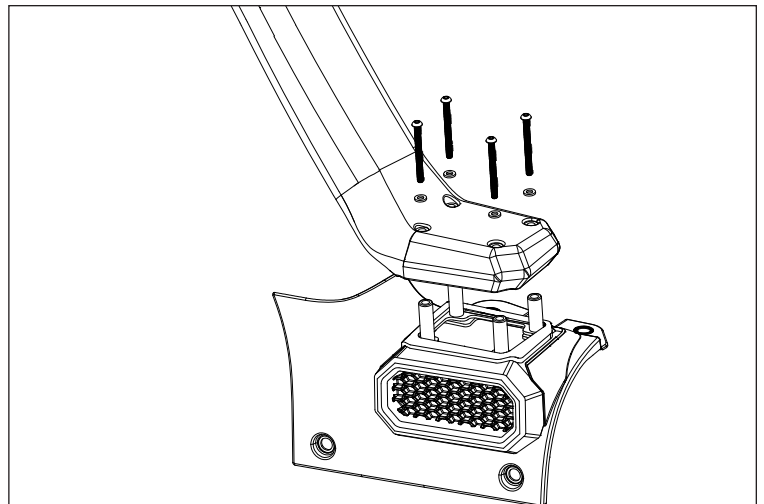

AmFib Snorkel; JL Patent Pending

26. Using 3in Clamp, attach Ram Inlet or Pre-Filter to High Mount Tube.

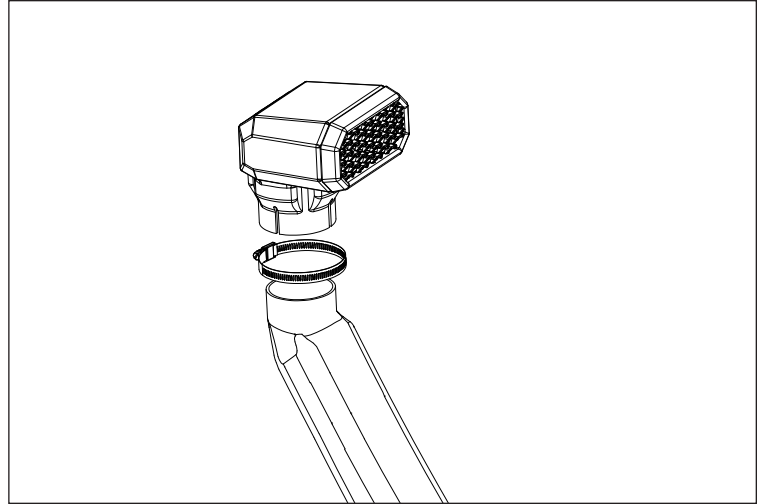

27. Adjust Rubber Bumper so it gently rests against windshield.

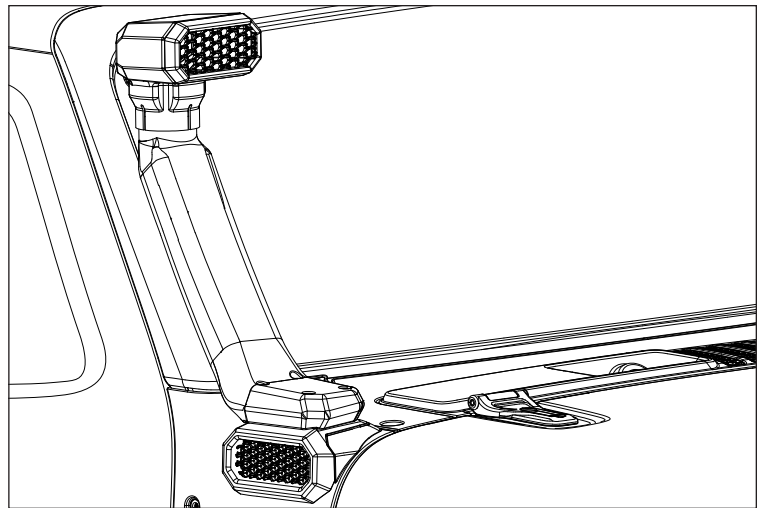

WARNING

The Rugged Ridge snorkel is designed to provide clean, dry air to the engine. There are many considerations to make when increasing a vehicle's fording depths. There are a variety of vehicle systems, beside the engine air intake, that are not intended to exceed the standard vehicle fording depth. It is the vehicle owner's responsibility to read and follow the owner's manual for appropriate water fording depths.