



RHINO-RACK

AERODYNAMIC & HEAVY DUTY ROOF RACK SYSTEMS

MULTI LADDER SLIDE SYSTEM

The following component fitting instructions make up your system

- Multi slide extension ladder rail assembly. (RR74)
- Multi slide stepladder rail assembly. (RR74)
- Conduit with K & C brackets fitment. (RR75)
- Conduit with crossbar clamps RPC4. (RR51)
- Ladder retaining straps RLS5. (RR47)
- Ladder stop. (RR77)
- Ladder cable locks Rail fitment. (RR01)
- Ladder cable locks crossbar fitment. (RR06)
- Load holder. (RR11)

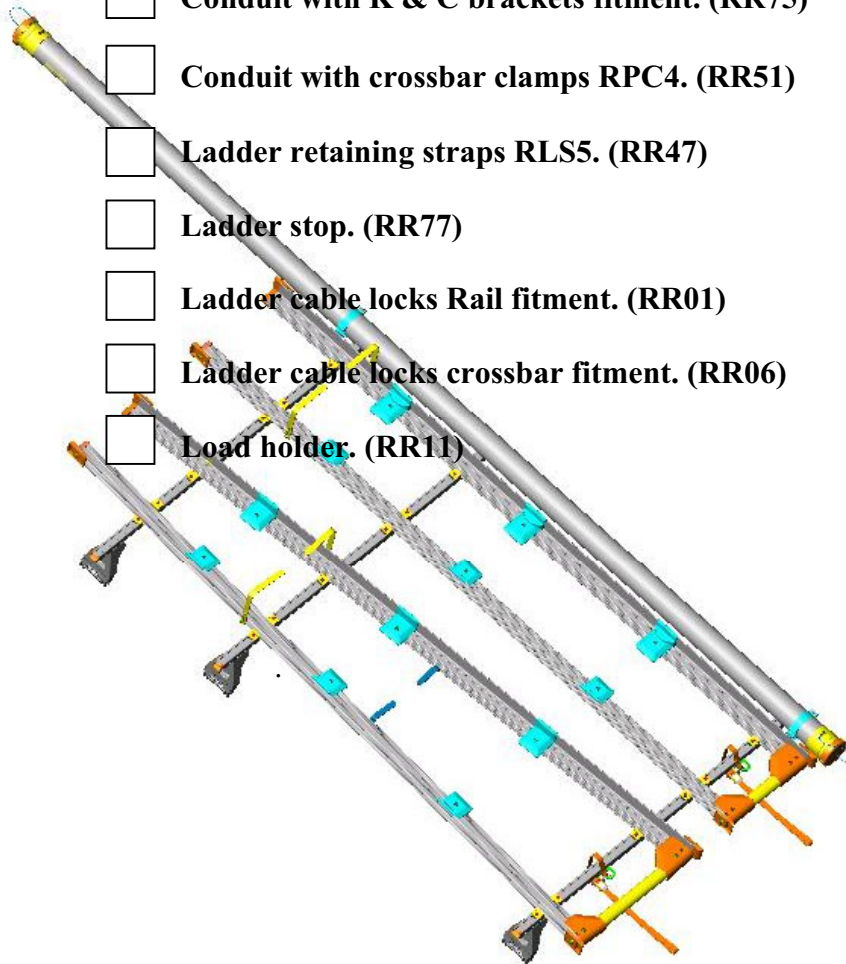



RHINO-RACK

AERODYNAMIC & HEAVY DUTY ROOF RACK SYSTEMS

MULTI SLIDE LADDER RACK FITTING INSTRUCTION.

The multi slide ladder rack system is designed to be fitted to the Rhino commercial crossbar system on either two or three bars.

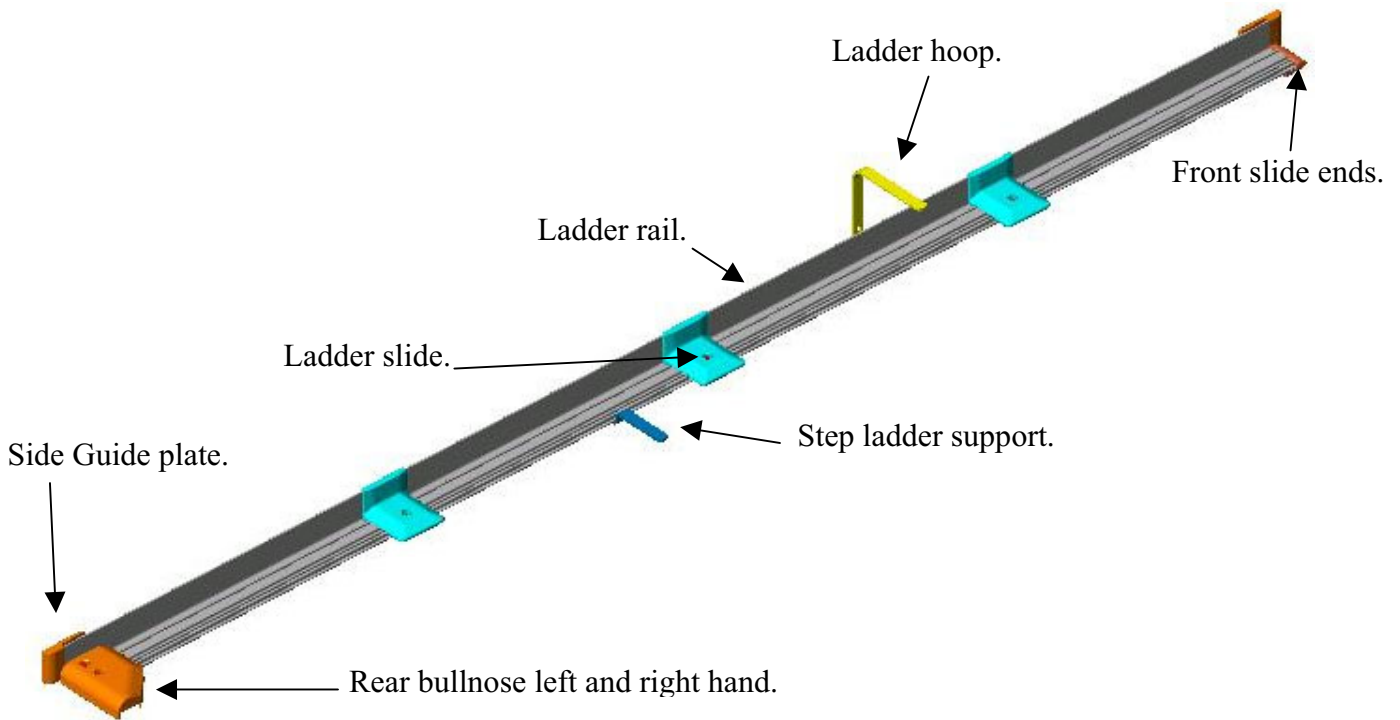

Ladder rail Assembly.

The assembly of the parts onto the ladder rail must be done in sequences so that parts do not have to be removed to fit other parts.

Ladder slide flat and stepped Pads.

Slide three M6 T bolts into the ladder rail outer T slot and assemble the pads, flat washers and nyloc nuts onto the T bolts, the return in the back of the pad hooks over the top edge of the rail, as per the diagram.

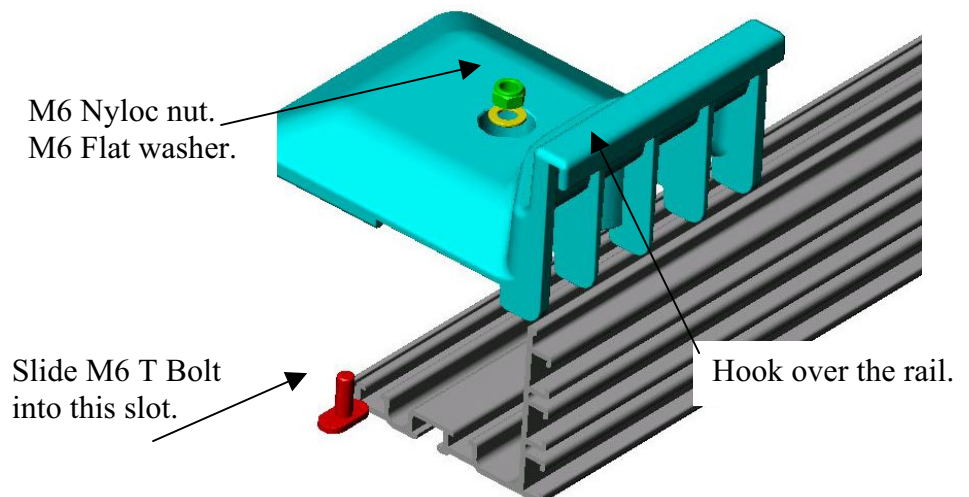

Ladder slide flat and stepped pads cont.

Do not tighten the nyloc nut as the ladder slides can be adjusted to suit your ladder length when the ladder rack is fully assembled on the vehicle.

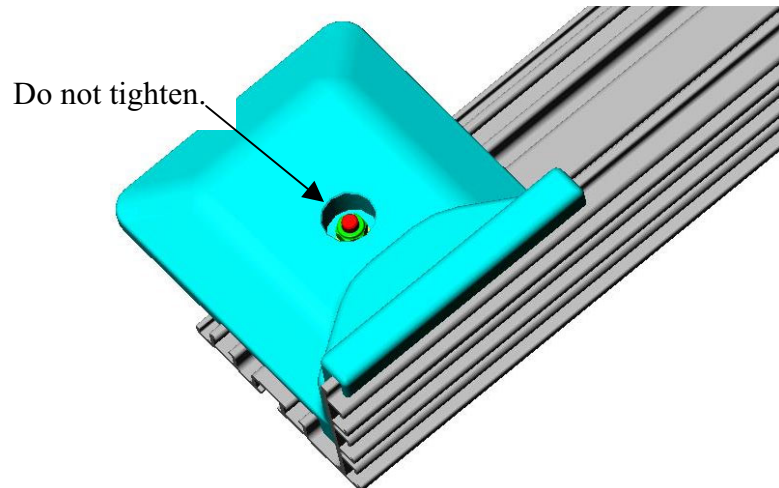

Ladder hoop.

Slide M8 T bolts into the ladder rail vertical section and one M8 T bolt into the ladder rail base section. Assemble the ladder hoop, M8 flat washers and M8 nyloc nuts onto the T bolts, as per the diagram.

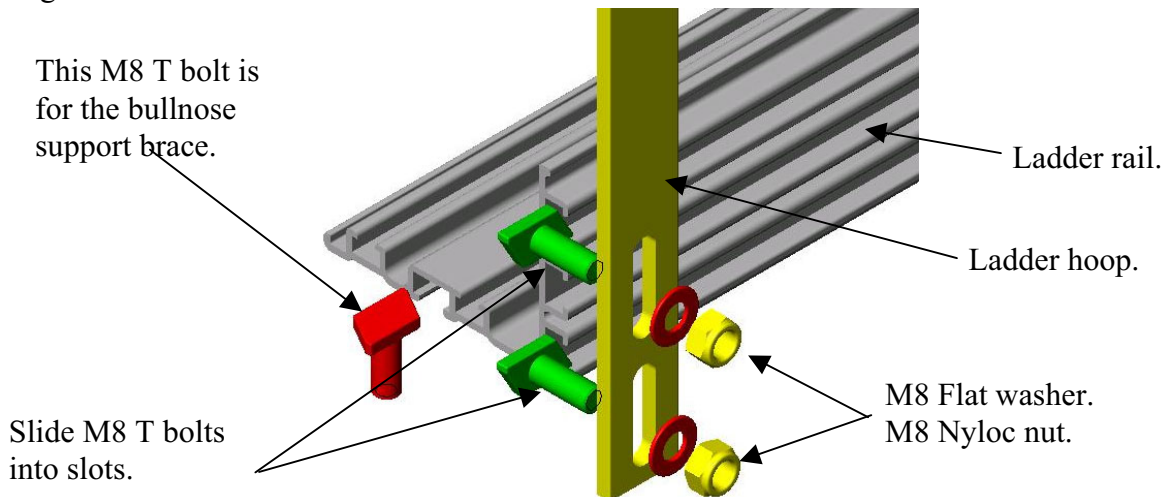

The Ladder hoop can be adjusted on the rail to suit the ladder length and width being carried.

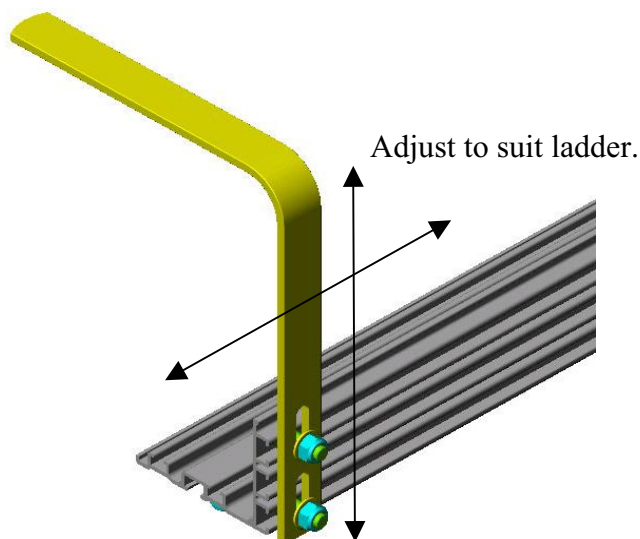

Step ladder support.

Slide one M8 T bolt into the ladder rail base section. Assemble the step ladder support bracket, M8 flat washers and M8 Nyloc nuts onto the T bolts, as per the diagram.

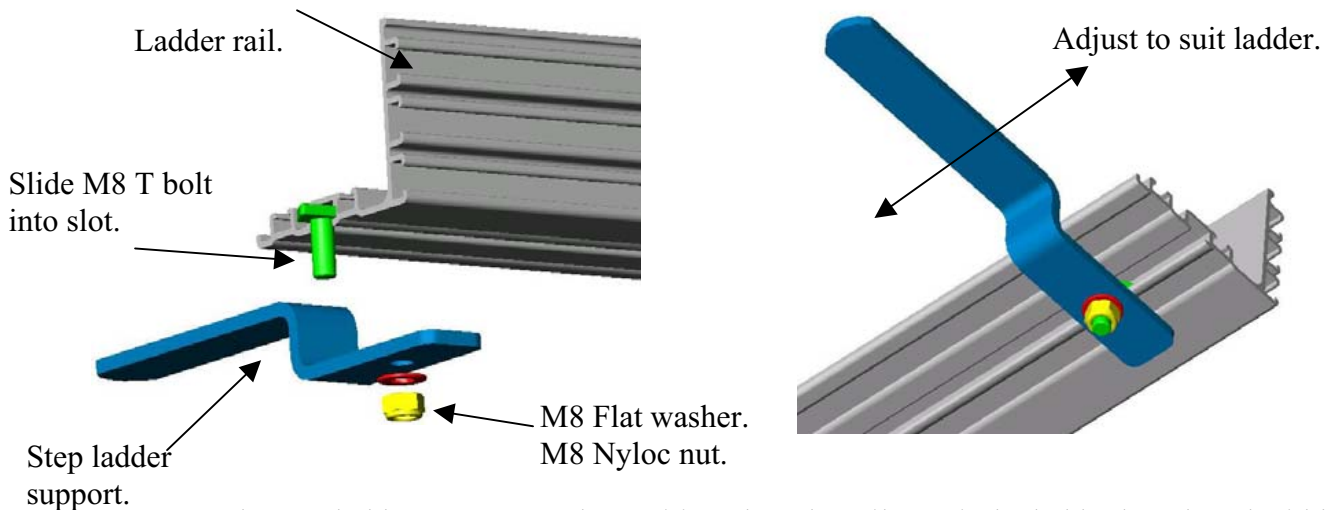

The Stepladder support can be positioned on the rail to suit the ladder length and width being carried.

Side guide plate and front end slide.

Slide M8 T bolts into the vertical section and M8 T bolts into the base section of the rail. Assemble the side guide plate, front-end slide, M8 flat washers and M8 nyloc nuts onto the T bolts as per the diagram. **Ensure that the guide plate and side slide are fully butted up against the ends of the ladder rail prior to tightening the nyloc nuts.**

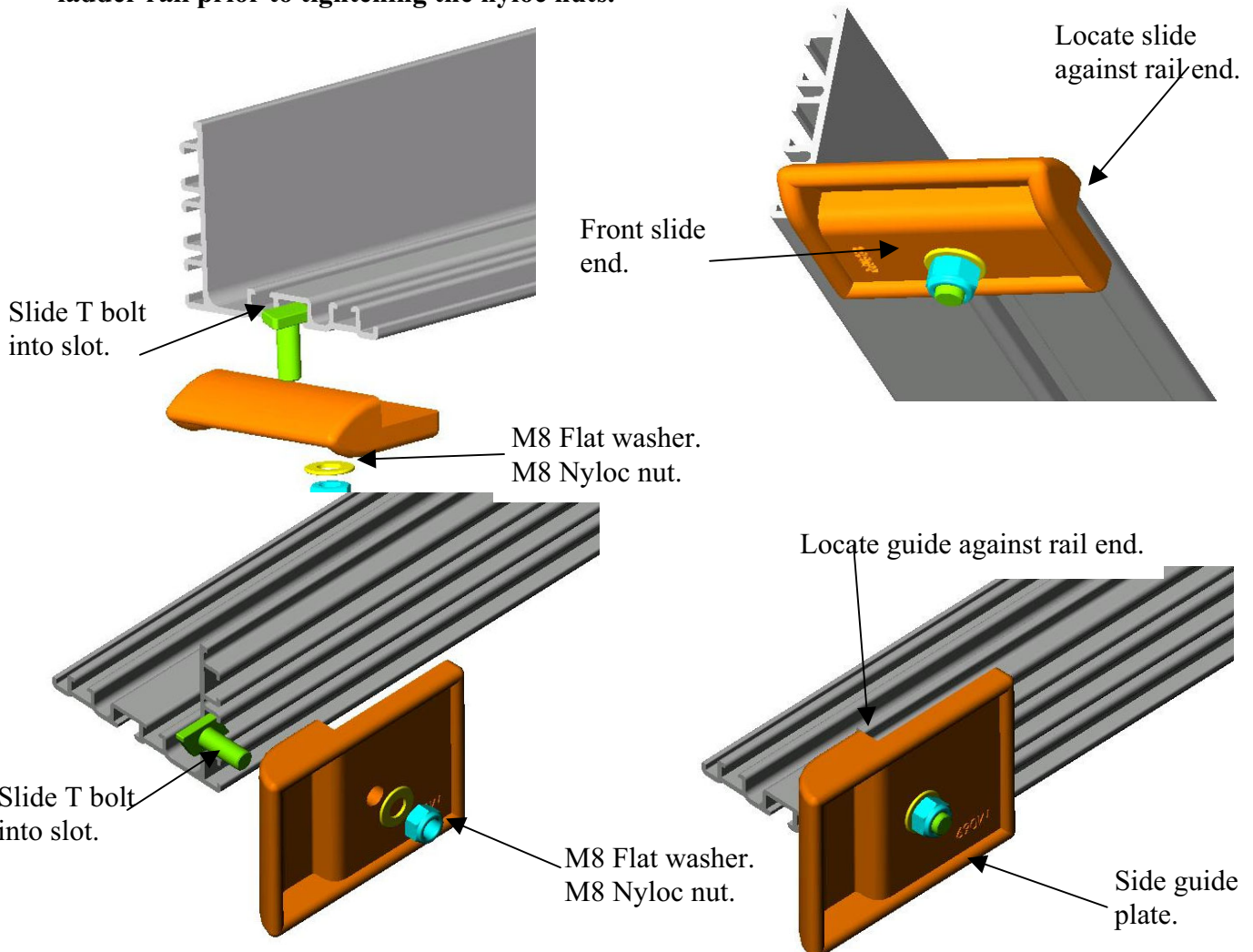

Rear bullnose.

Slide M6 T bolts into the upper surface of the base section of the rail. Assemble the bullnose, M6 flat washer and M6 nyloc nuts onto the T bolts as per the diagram. **Ensure that the bullnose is fully locate up against the end of the ladder rail prior to tightening the nyloc nuts.**

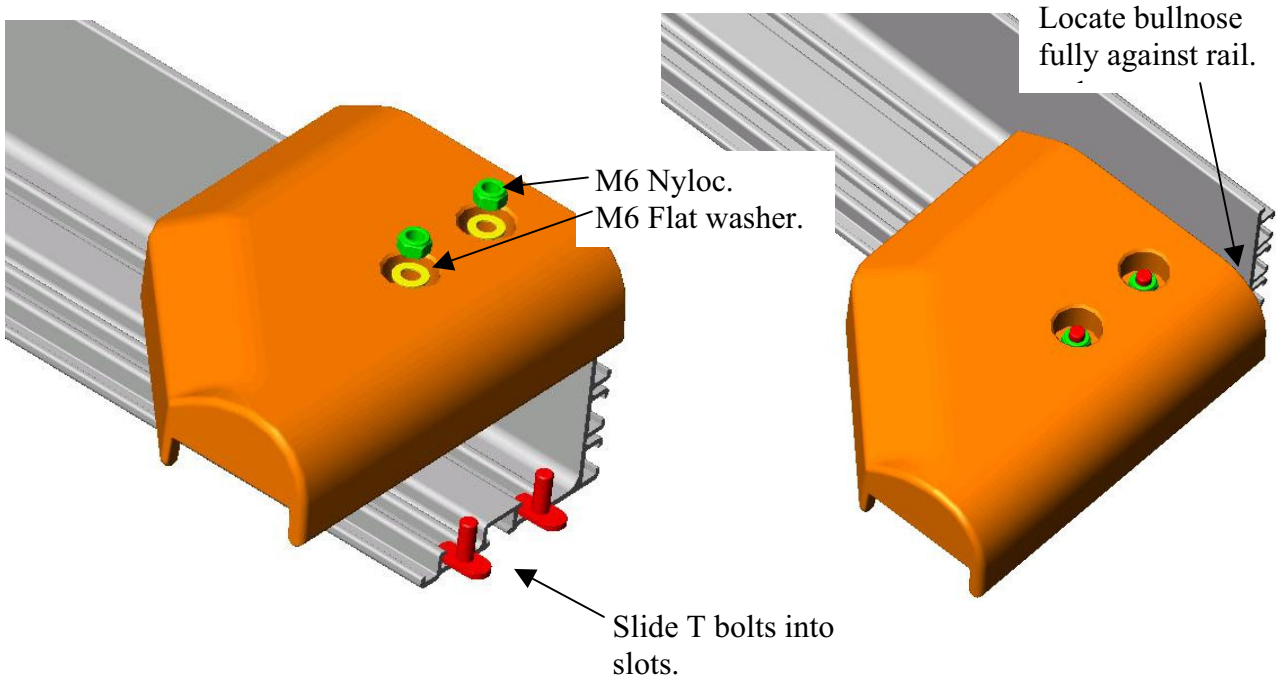

General ladder rail assembly layout.

The ladder rail assemblies are set-up as a left and right, with a left and right rear bullnose. The step ladder rail assembly has the flat ladder slide pads on both rails, the extension ladder rail has flat ladder slide pads on the left side rail and stepped ladder slide pads on the right side rail so that the ladder extension pullies and rigging clear the slide pads and ladder rail when loaded.

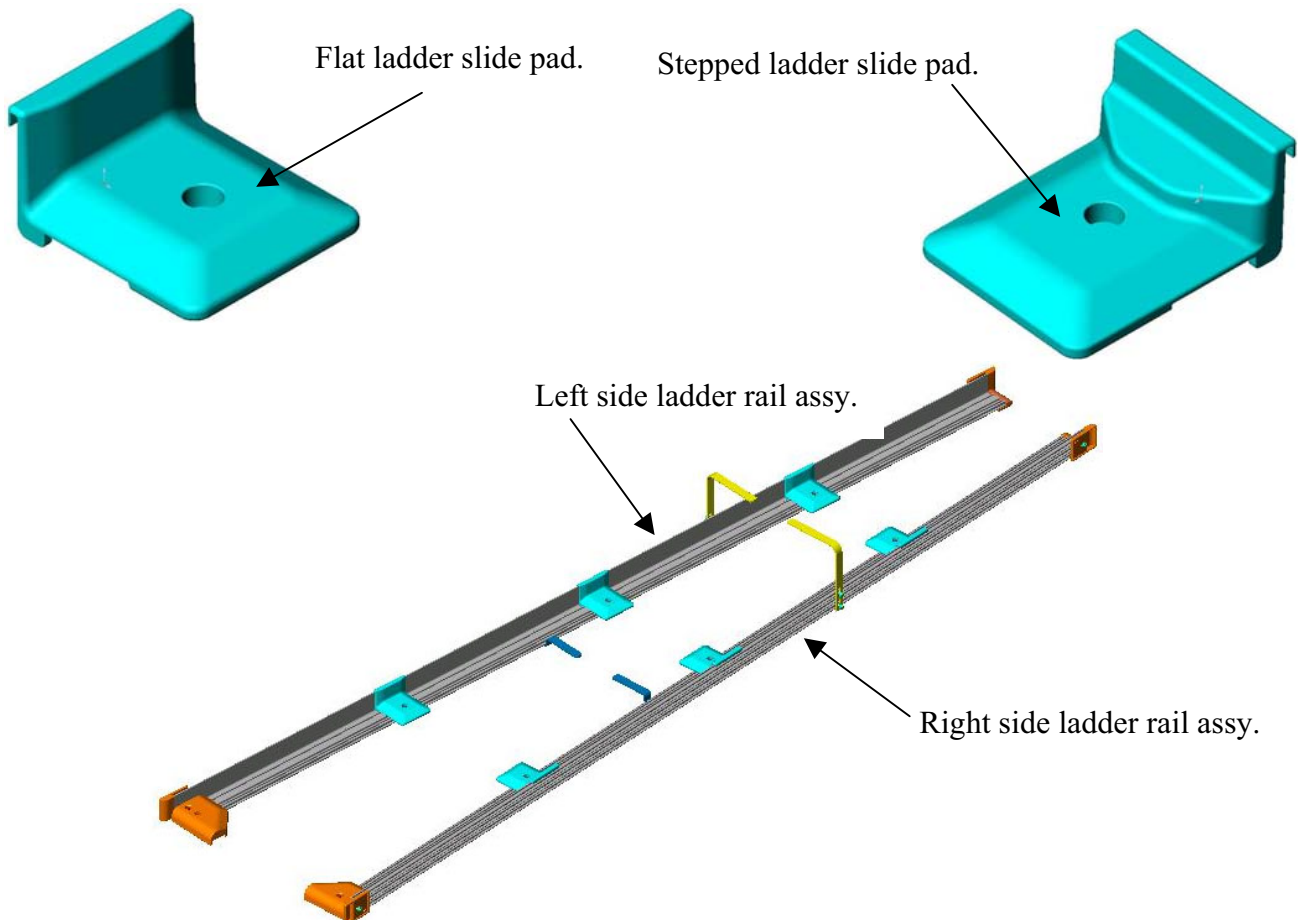

MULTI SLIDE LADDER RACK FITTING INSTRUCTION.

Fitting the ladder rails to the crossbars.

The assembly of the rails onto the crossbars is the same for all ladder rail configurations and placement of the ladder rails is dependent on the customer's specific ladder layout requirements.

Step and extension bullnose support brace to the ladder rail.

Slide the bullnose onto the support brace and centralise the bullnose as per the diagram.

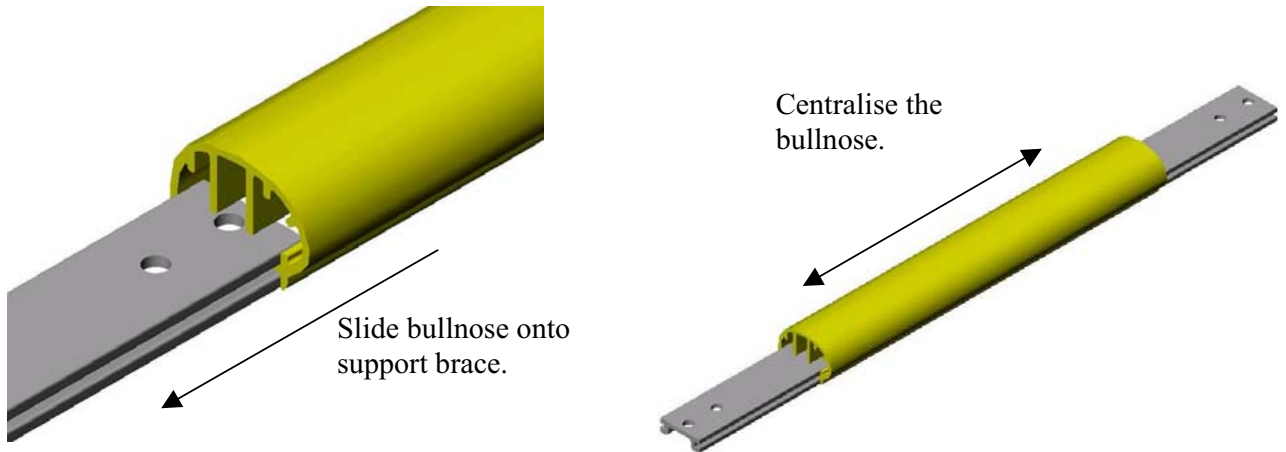

Assemble the bullnose support brace onto the underside of the ladder rails using the M8 T bolts located into the T slot prior to fitting the rear bullnoses. Assemble the M8 flat washers and M8 nyloc nuts, do not fully tighten the nuts as some adjustments may be required when fitting the ladder rails to the crossbars.

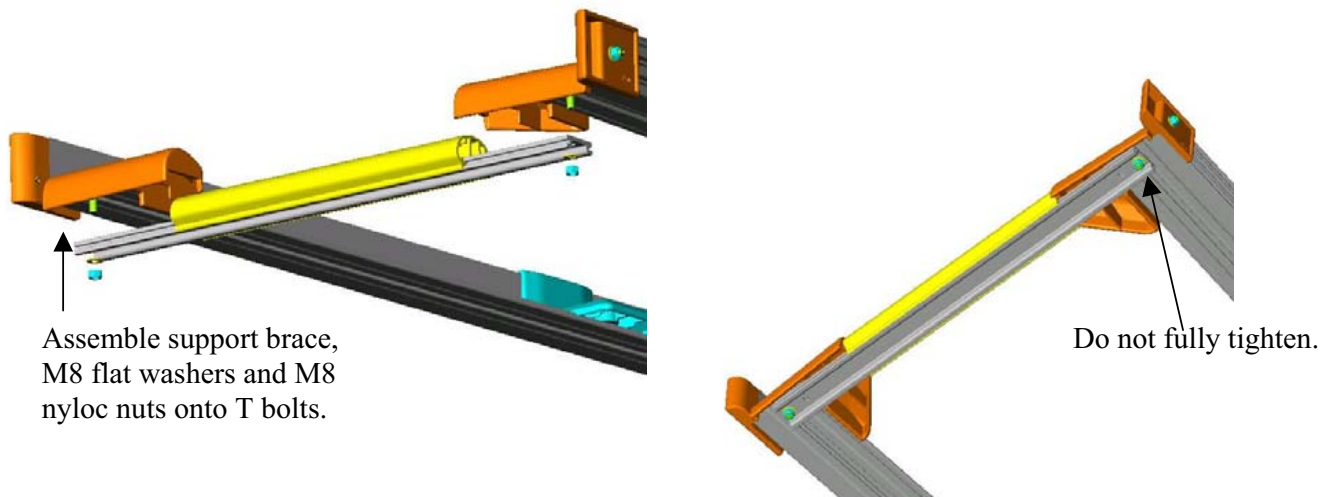

Ladder rails to crossbar fitment.

Position the ladder rail onto the crossbar as per the customers required layout, install the locking tab onto the ladder rail. Check the ladder rail positioning. Tighten the locking tab attachment bolt. Check that the channel nut is fully located across the crossbar as per the diagram.

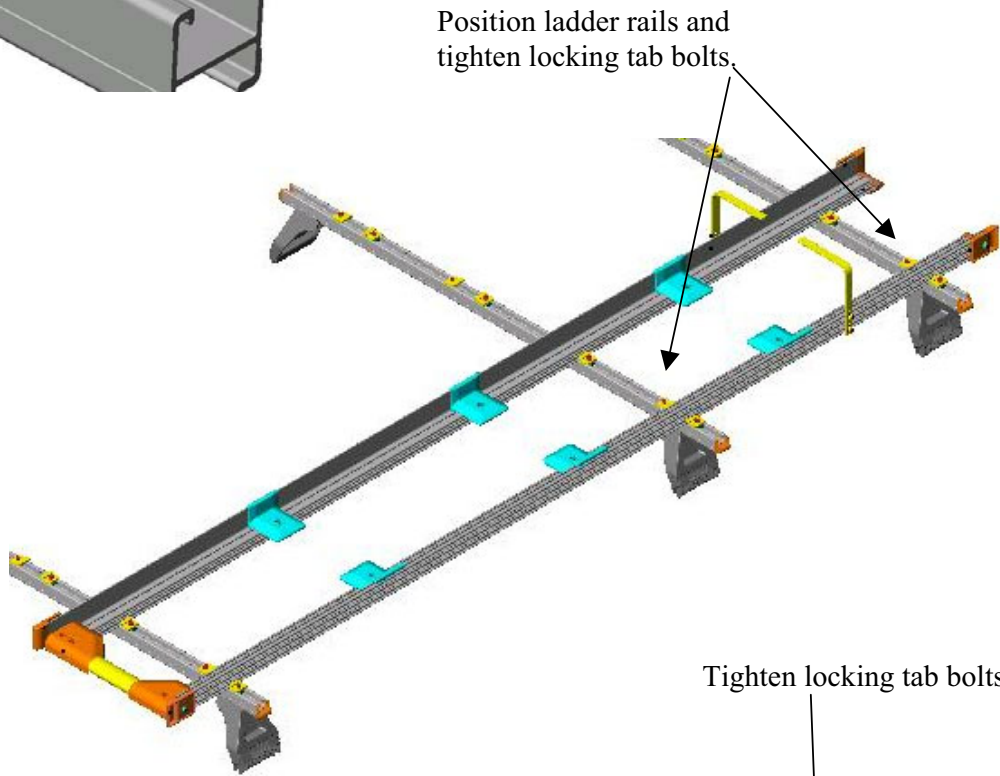
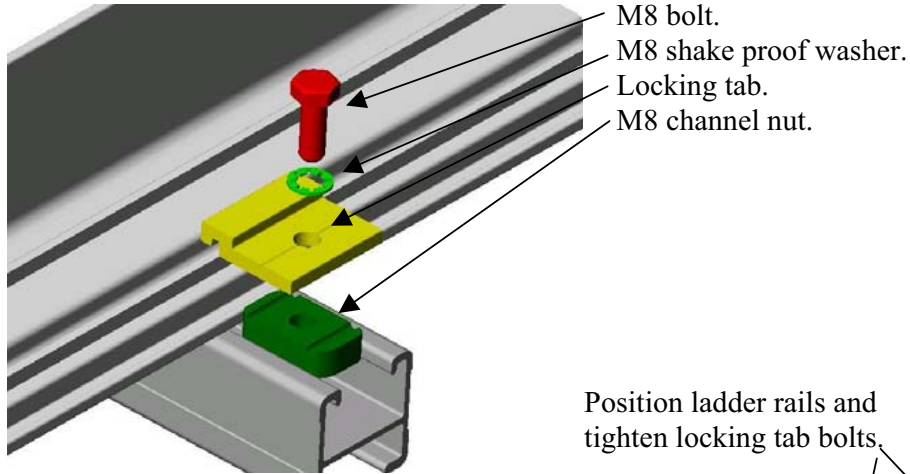

Tighten locking tab bolts.

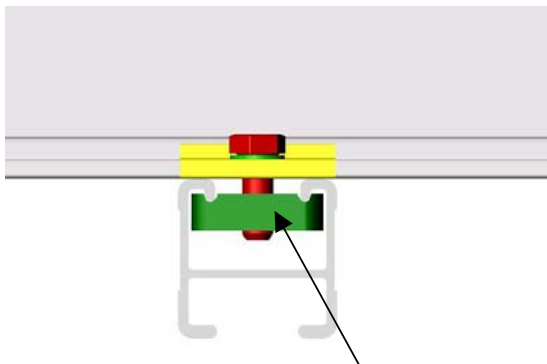

Check that the channel nuts are fully located across the bar after tightening.

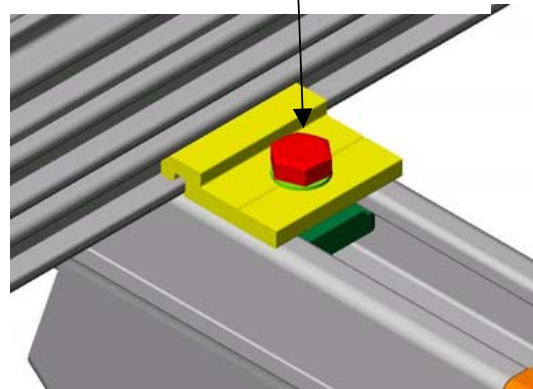

RECOMMENDATIONS

It is essential that all bolt connections be checked after driving a short distance when you first install your Rhino-Rack Multi Slide ladder rack system. Bolt connections should be checked again at regular intervals (probably once a week is enough, depending on road conditions, usage, loads and distances travelled). You should also check the roof bars each time they are refitted. Crossbars and Multi Slide rails should be cleaned and all screw threads should be lubricated at regular intervals. Rhino-Rack offers a 3 Year warranty to the original purchaser of the Rhino-Rack Multi Slide System. Rhino-Rack cannot be held responsible for incorrect mounting of the Rhino-Rack Multi Slide System or for usage that exceeds vehicle and production tolerances.

Make sure to fasten your load securely. Please ensure that all loads are evenly distributed and that the centre of gravity is kept as low as possible. Use only non-stretch fastening ropes or straps.

SENSITIVITY TO CROSSWINDS, BEHAVIOUR IN CURVES AND BRAKING

The handling characteristics of the vehicle changes when you transport a load on the roof. For safety reasons, we recommend you exercise extreme care when transporting wind-resisting loads, special consideration must be taken into account when braking.

PLEASE REMOVE CROSSBARS WHEN PUTTING VEHICLE THROUGH AN AUTOMATIC CAR WASH.

LOAD RATINGS

Maximum permissible load is 100Kg per pair of roof bars (include the weight of the roof bars, 5kg. When roof bars are to be used in extreme off-road conditions please build a safety factor of 1.5 into this load limit (66kg). Note for dealers and fitters. It is your responsibility to ensure instructions are given to the end user or client.

RHINO-RACK	No: RR74
Prepared By: Alan Marshall	Issue: 01
Authorised By: Gary England	Issue Date: 21/12/01