

Fitting instructions

Make: **Kia**

Sorento; 2012->

Type: 5644

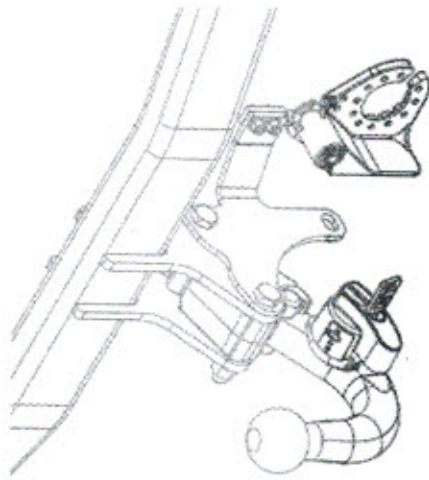

- NL** Montagehandleiding
- GB** Fitting instructions
- D** Montageanleitung
- F** Instructions de montage
- S** Monteringsanvisningar
- DK** Montagevejledning
- E** Instrucciones de montaje
- I** Istruzioni per il montaggio
- PL** Instrukcja montażu
- SF** Asennusohjeet
- CZ** Pokyny k montáži
- H** Szereelési útmutató
- RUS** Руководство для монтажа

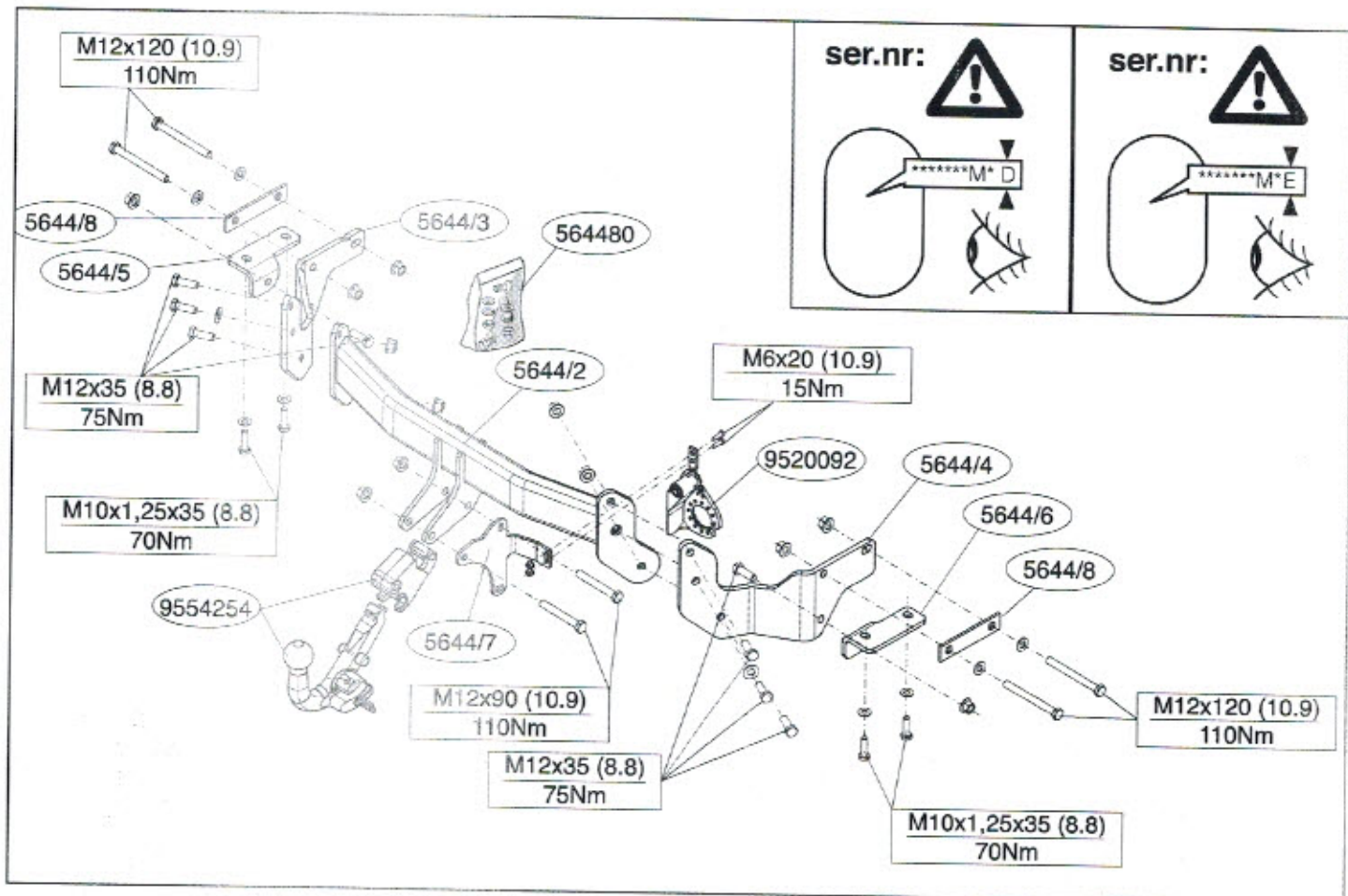



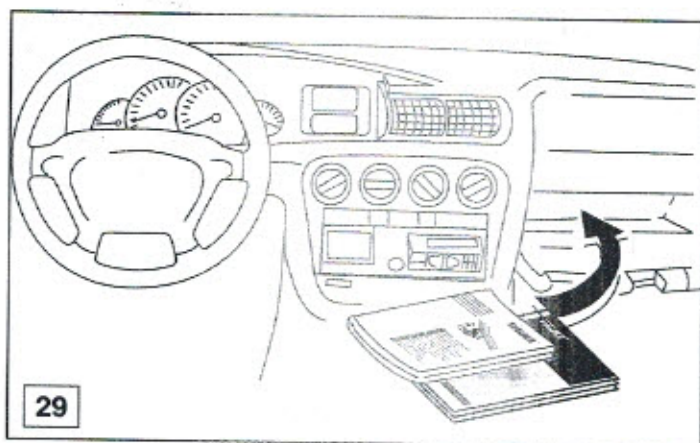

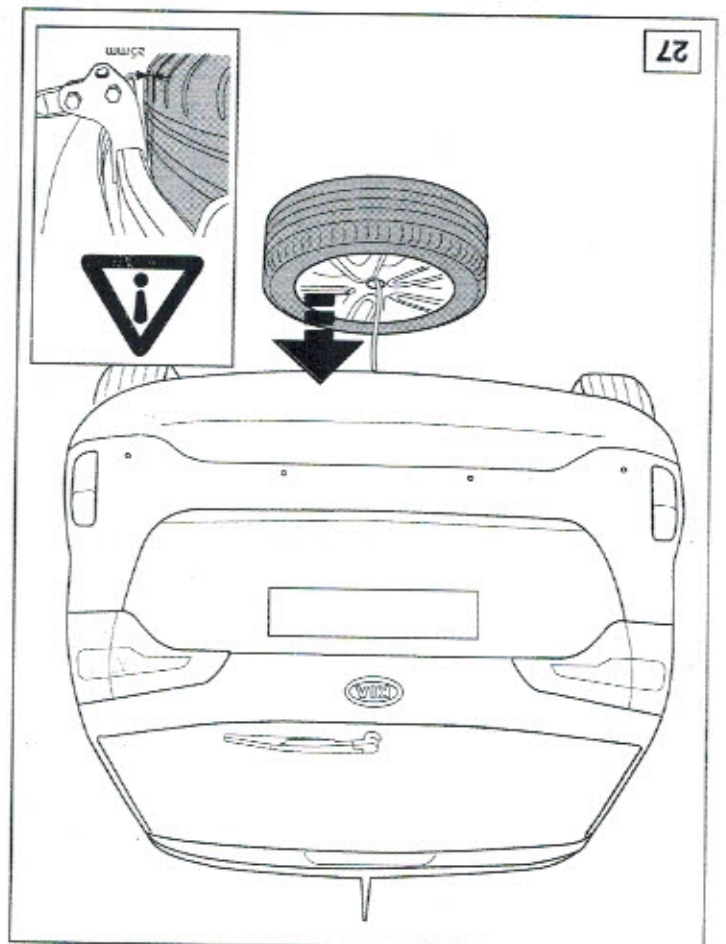
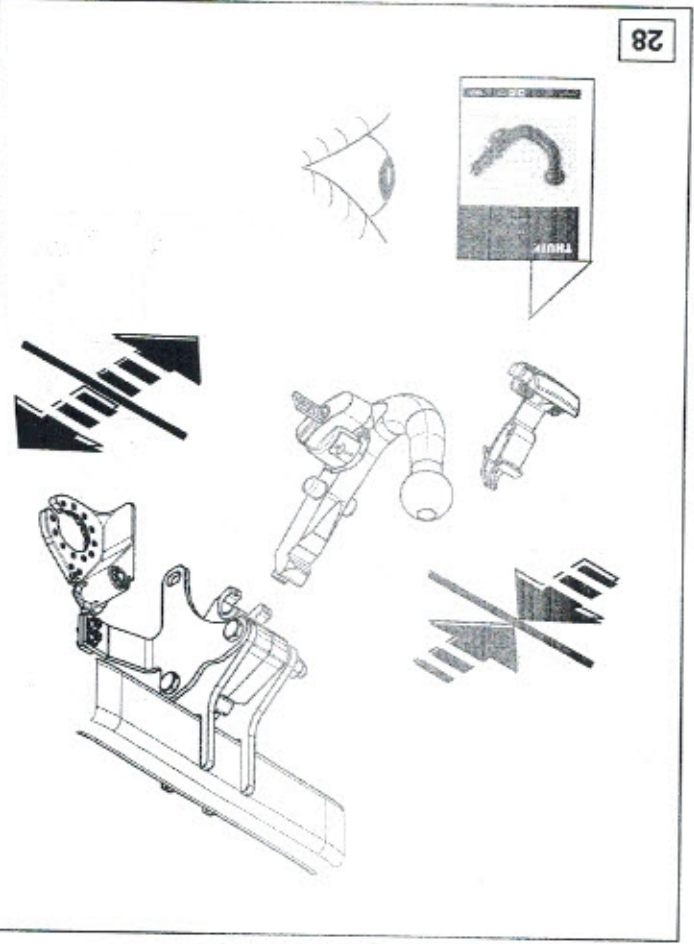
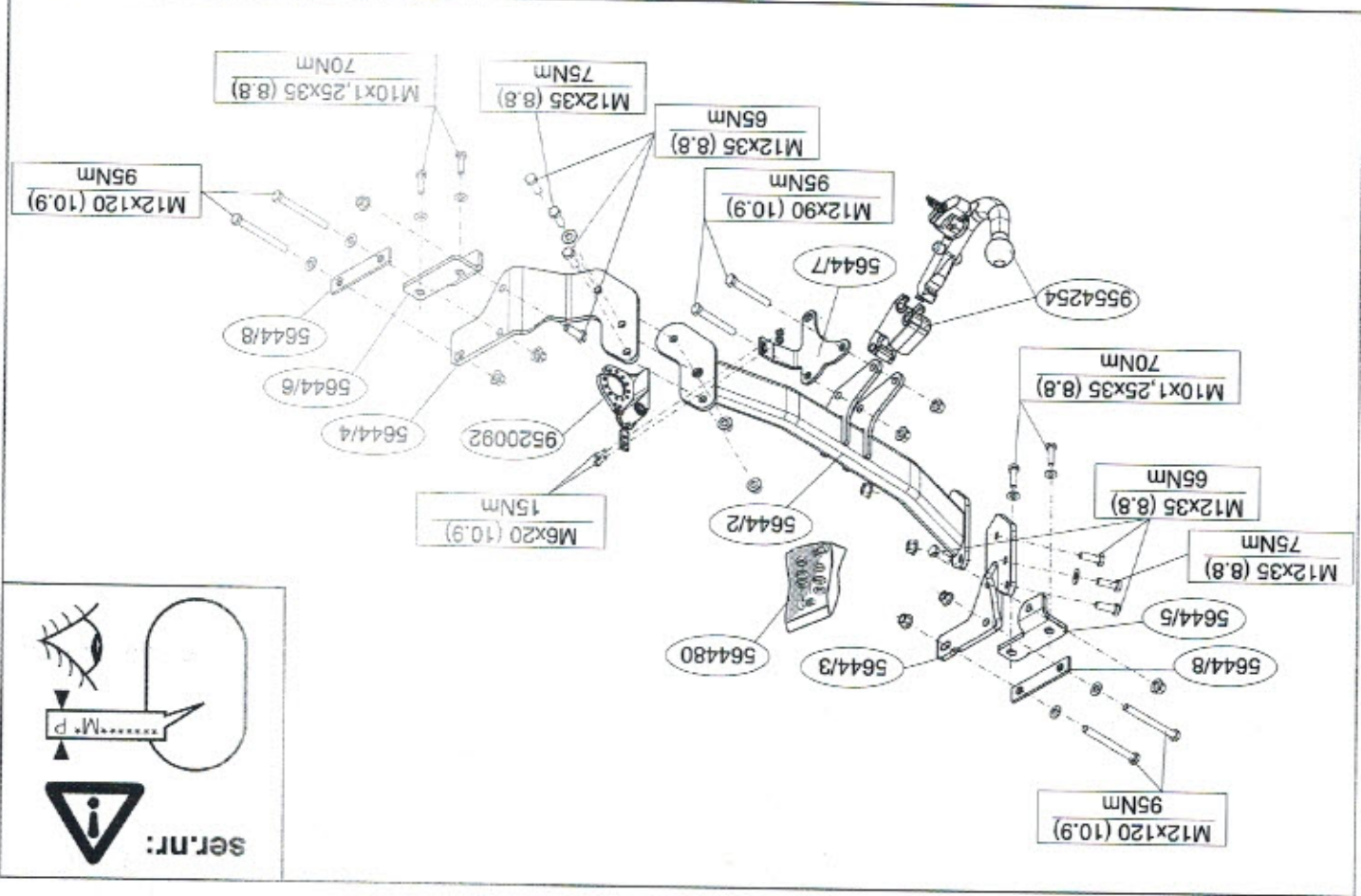

© 564472/01-11-2012/1

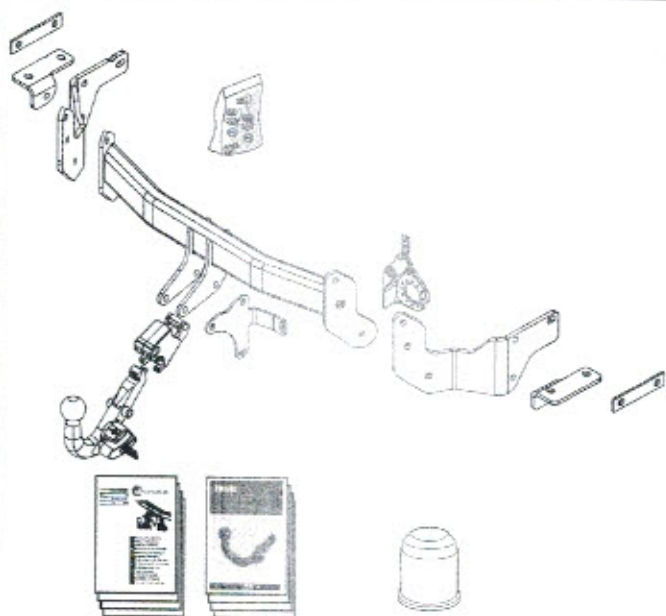
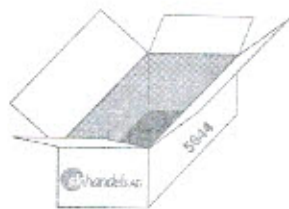

© 564472/01-11-2012/22





- | | | | |
|---|------------------------|---|-----------|
|  | (2x) M6x20 (10.9) |  | (2x) M6 |
|  | (4x) M10x1,25x35 (8.8) |  | (12x) M12 |
|  | (8x) M12x35 (8.8) |  | (4x) M10 |
|  | (2x) M12x120 (10.9) |  | (2x) M12 |
|  | (2x) M12x90 (10.9) |  | (4x) M12 |

© 564472/01-11-2012/3



○ Connect

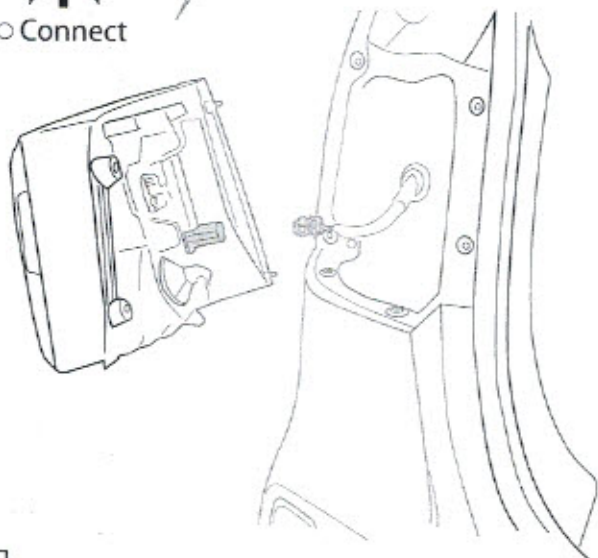

25

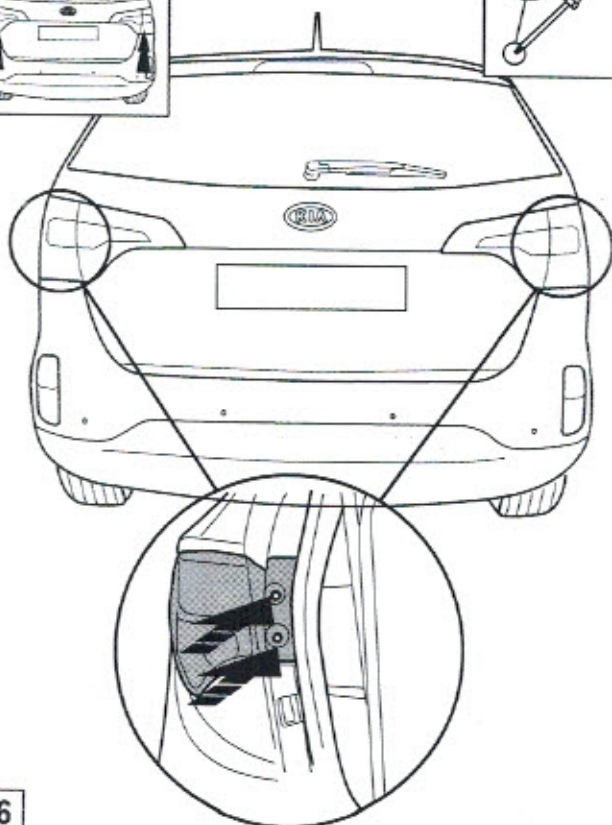
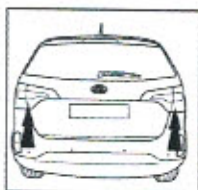

26

© 564472/01-11-2012/20

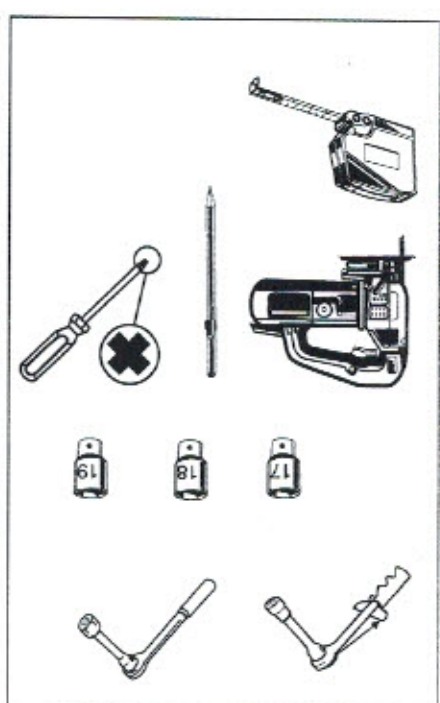
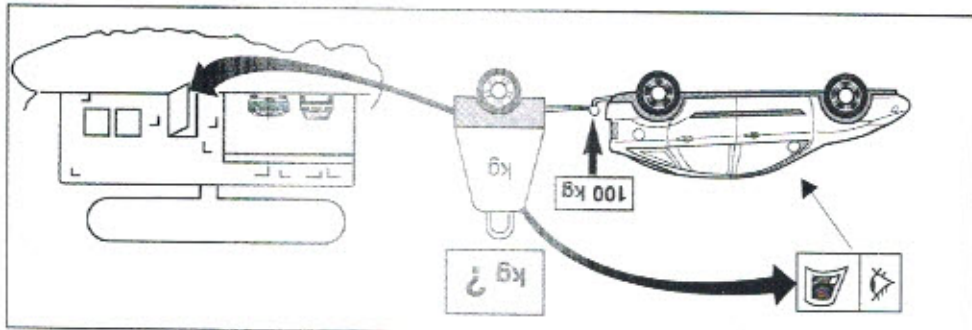
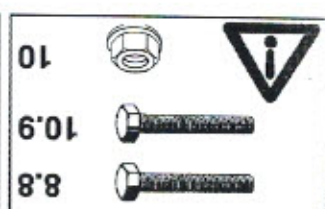
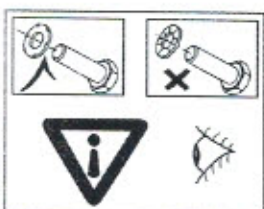
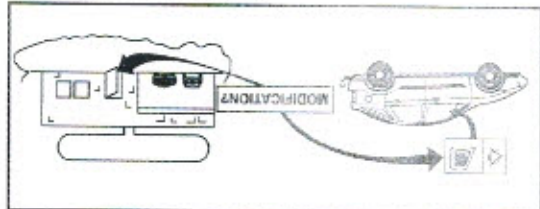

D-Value : 15,5 kN

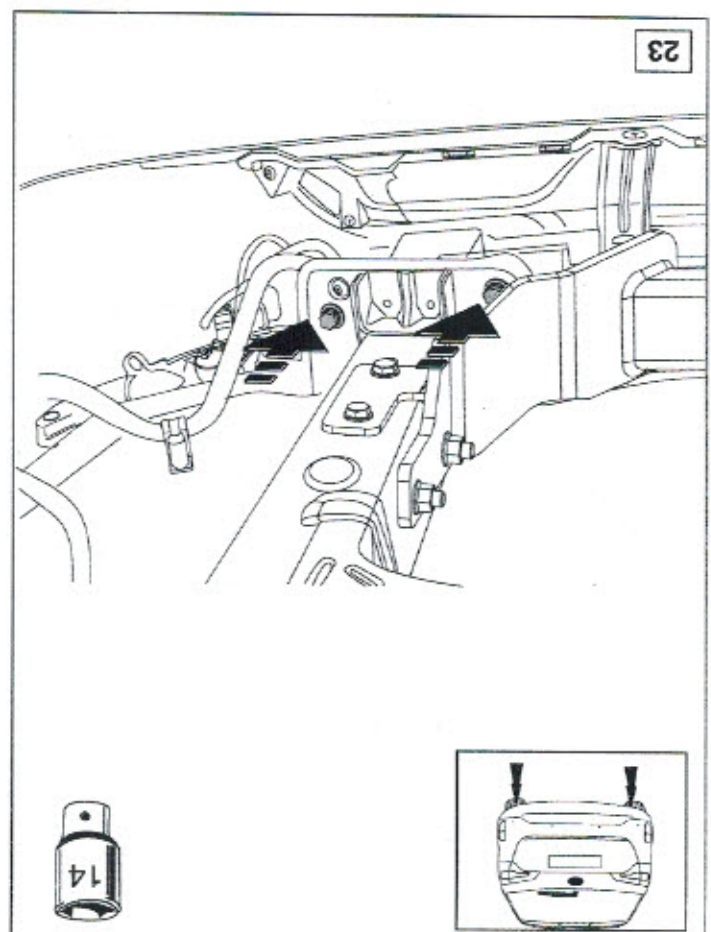
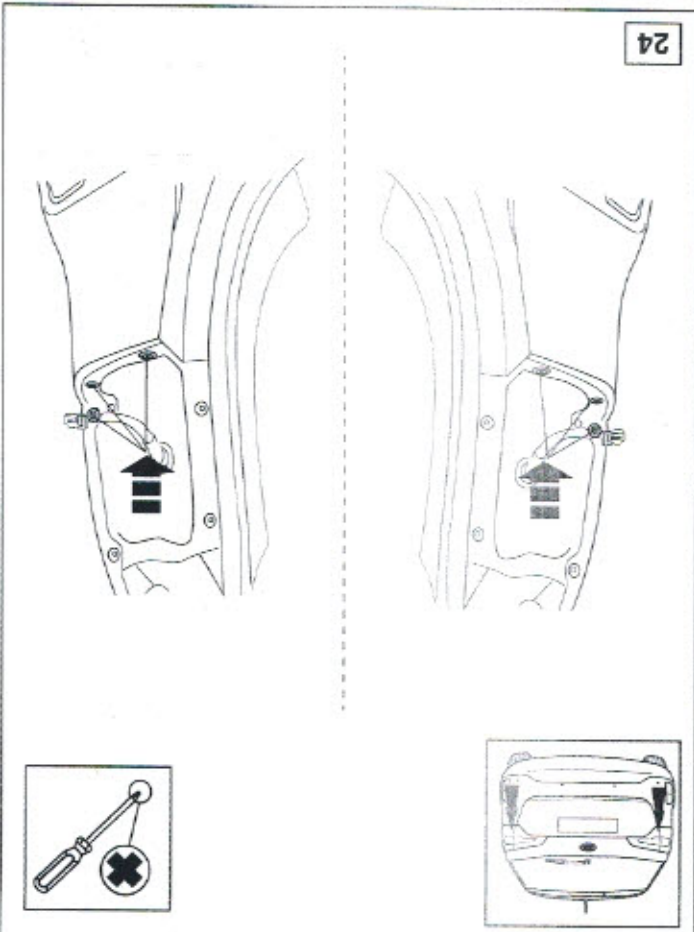
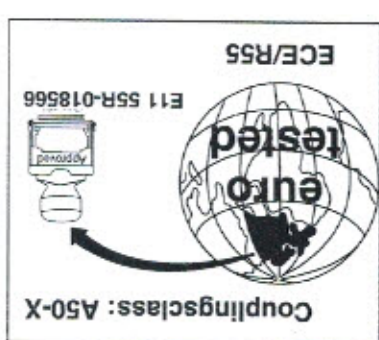



NL.

* **s.k.handels AG** is niet aansprakelijk voor de schade die het direct of indirect gevolg is van onjuiste montage, daaronder begrepen gebruik van niet-geschikte gereedschappen en het gebruik van andere dan de voorgeschreven montagewijze en middelen, dan wel onjuiste interpretatie van dit onderhavig montagevoorschrift.

GB.

NOTE:

* **Should this installation process entail the cutting of the bumper – conformation MUST be obtained by the installation engineer of the customer's acceptance prior to completion. Thule Towing Systems do not accept responsibility for any matters arising as a result of this miscommunication.**

All measurements are in mm!

* **s.k.handels AG** is not liable for damage caused directly or indirectly by incorrect assembly, including the use of unsuitable tools, the use of other assembly methods and means than the ones outlined, and the incorrect interpretation of these assembly instructions.

D.

HINWEISE:

* Die für das Fahrzeug zugelassene Anhängelast ist den Fahrzeug Unterlagen zu entnehmen. Bei Änderungen des Fahrzeuggewichtes muß die höchstzulässige Anhängelast gegebenenfalls aus dem D-Wert nachgerechnet werden.

Auskunft hierüber kann Ihr Fachhändler oder der TÜV geben.

* Elektrische Anlage gemäß SIVZO anbringen.

* **s.k.handels AG** haftet nicht für Schäden, die als direkte oder indirekte Folge einer nicht ordnungsgemäßen Montage auftreten, darunter fallen auch die Benutzung von ungeeigneten Werkzeugen, andere als die vorgeschriebenen Montageverfahren und Montagemittel sowie eine fehlerhafte Interpretation der betreffenden Montageanweisung.

F.

* **s.k.handels AG** décline toute responsabilité pour les dommages qui pourraient directement ou indirectement résulter d'un montage incorrect, y compris l'utilisation d'outils inappropriés et l'utilisation d'un mode d'emploi et de moyens autres que ceux prescrits, ou bien résulter d'une interprétation inexacte des présentes instructions de montage.

S.

* **s.k.handels AG** är inte ansvariga för skada som orsakats direkt eller indirekt av felaktig montering, inklusive användning av olämpliga verktyg, andra monteringsmetoder och processer än de som beskrivs, samt felaktig tolkning av dessa monteringsinstruktioner.

DK.

* **s.k.handels AG** er ikke ansvarlig for skade der direkte eller indirekte er forårsaget af forkert montage, herunder også iberegnet brug af forkert værktøj og anvendelse af anden montage metode og andre montage midler end de foreskrevne samt fejltolkning af den medfølgende montagevejledning.

E.

* **s.k.handels AG** no se responsabiliza por daños causados, directa o indirectamente, por un montaje incorrecto, incluyendo el uso de herramientas inadecuadas, por el uso de métodos de montaje y medios distintos a los indicados y por la interpretación incorrecta de estas instrucciones de montaje.

I.

* **s.k.handels AG** non può essere ritenuta responsabile per eventuali danni direttamente o indirettamente dovuti ad un errato montaggio, intendendo con ciò anche l'uso di attrezzi non idonei e l'uso di metodi e mezzi di montaggio diversi da quelli prescritti, nonché all'errata interpretazione delle seguenti istruzioni di montaggio.

PL.

* Firma **s.k.handels AG** nie ponosi odpowiedzialności za straty poniesione

© 564472/01-11-2012/5

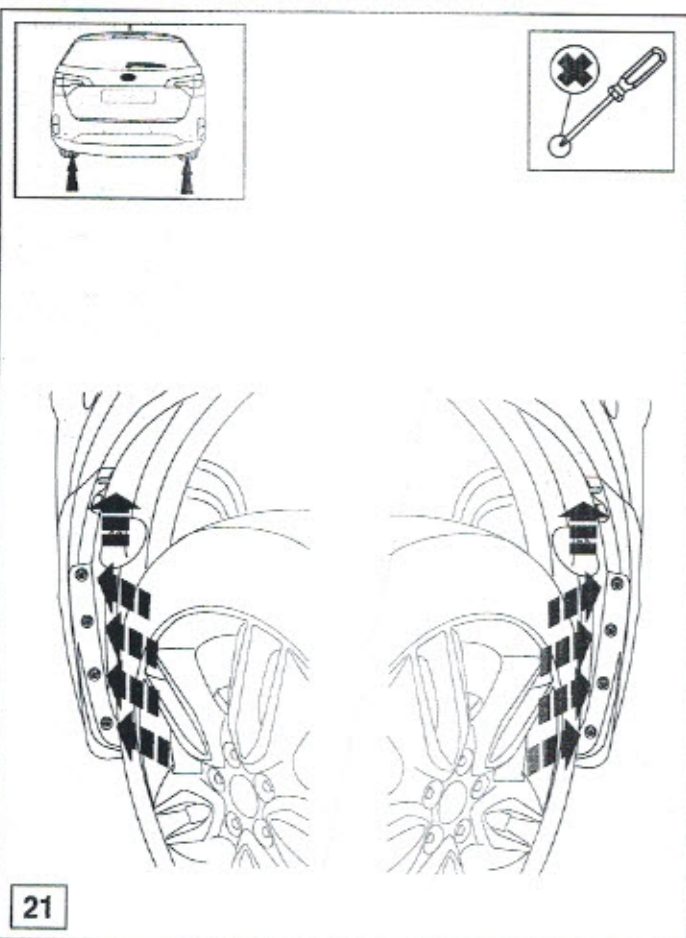

21

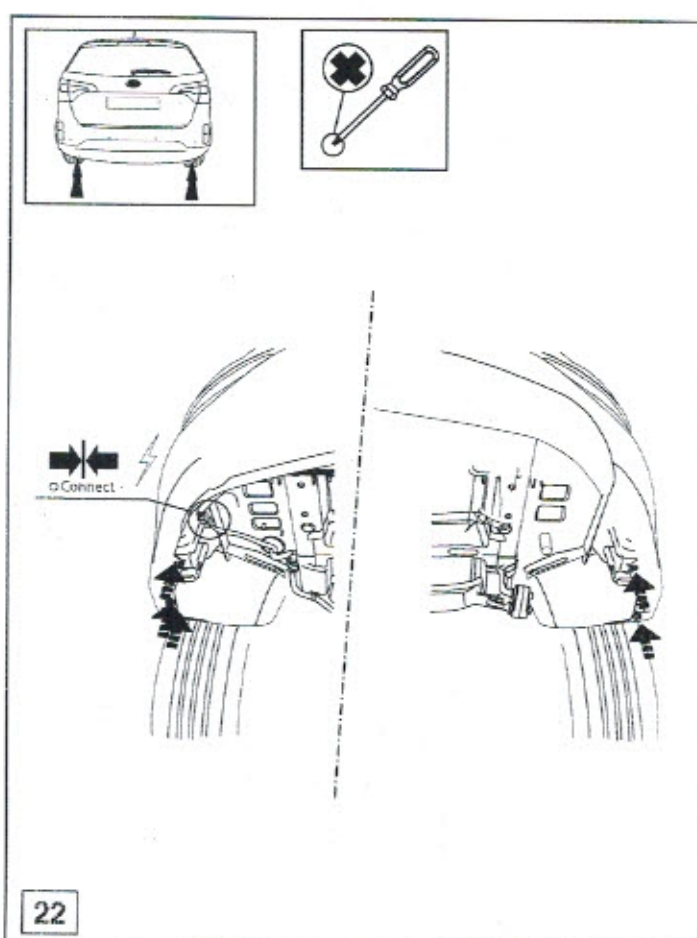

22

© 564472/01-11-2012/18

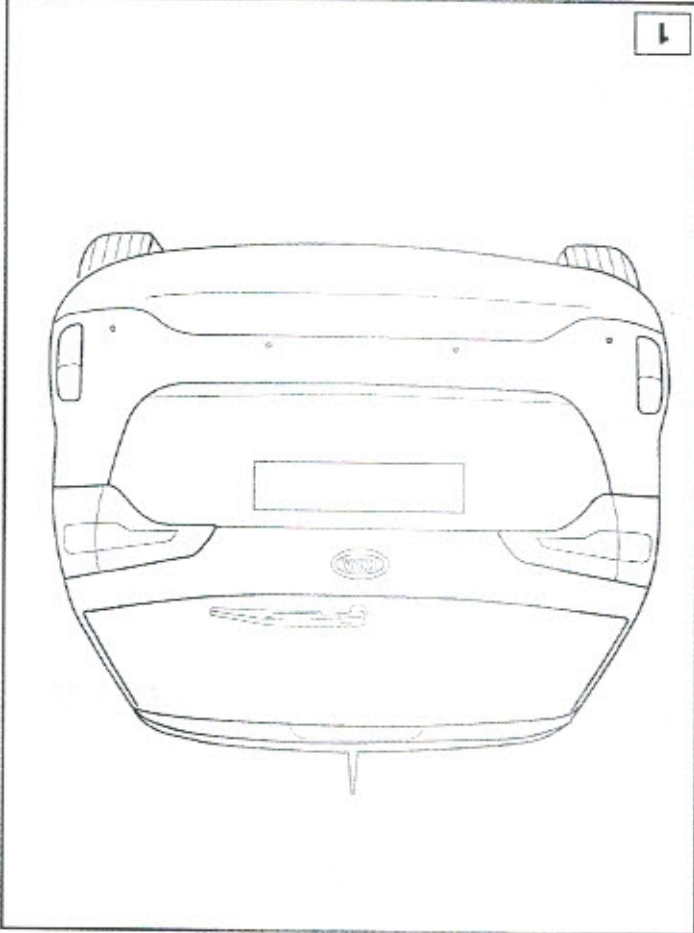

1

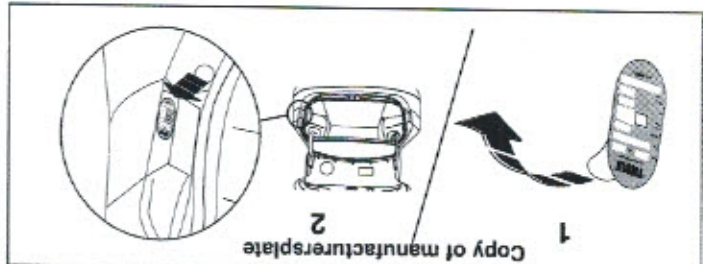

Copy of manufacturer's plate

posřednio lub bezpořednio na skútek niewiásçiwego montażu, w tym użycia niewiásçiwych narzędzi i sposobów montażu niezgodnych z inst-
rukcją, oraz niezastosowanie się do treści instrukcji.

SF.
s.k.handels AG ei ole vastiussa viitumisesta, joka on suoraan tai epä-
suoraan aiheutunut väärästä asennuksesta samoin kuin sopimattomien
työkälien käytöstä, muiden kuin ohjeissa mainittujen asennusmenetel-
mien tai välineiden käytöstä sekä kyseisten asennusohjeiden väärinl-
kinnasta.

CZ.
Společnost s.k.handels AG neodpovídá za přímé ani nepřímé škody
způsobené nesprávnou montáží, včetně použití nevhodných nástrojů,
použití jiných metod montáže a prostředků než uvedených a
nesprávným pochopením těchto pokynů k montáži.

H.
A s.k.handels AG nem vállal felelősséget a nem megfelelő szerelésből
közvetlen vagy közvetett módon következő károkért. Ez vonatkozik a
eszközök alkalmazására, valamint a szerelési útmutató téves értel-
mezésére.

RUS.
Фирма s.k.handels AG не отвечает за ущерб, являющийся прямым или косвен-
ным следствием неправильного монтажа, в том числе использования недопу-
стящих инструментов и применения иного способа монтажа или других средств,
чем предписано в инструкции, либо неправильного истолкования настоящей
инструкции по монтажу.

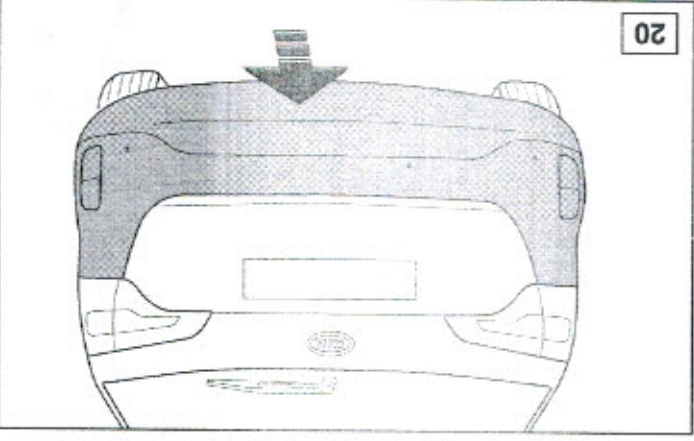

20

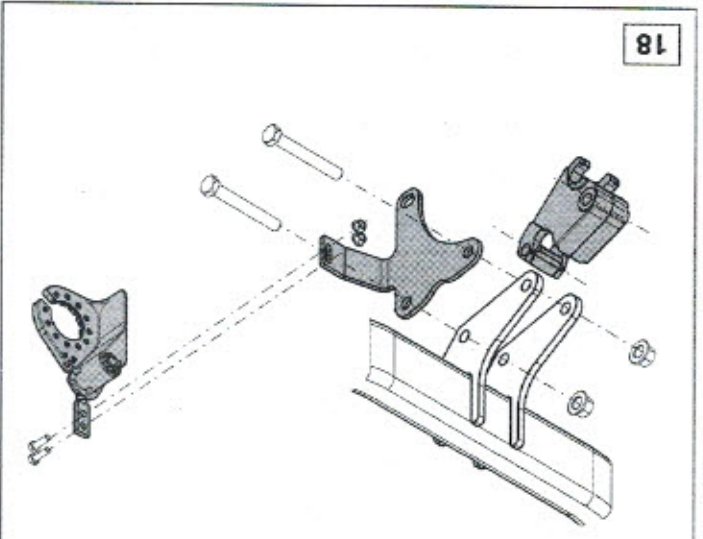

18

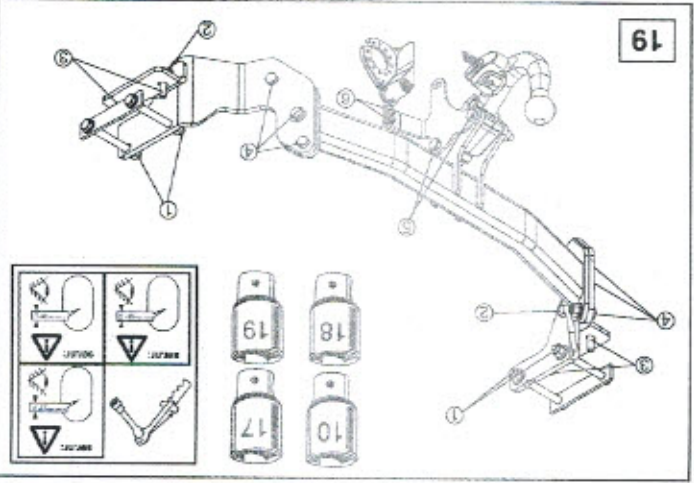

19

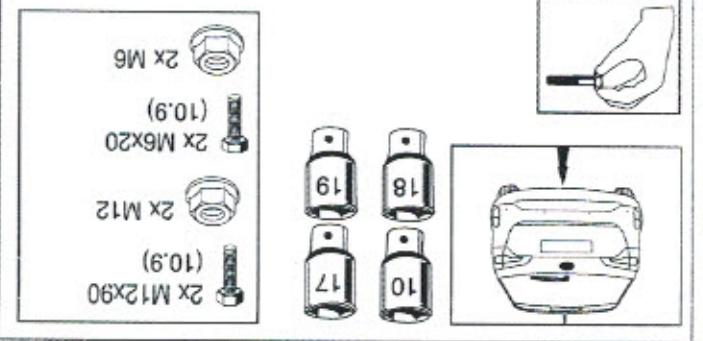

- 2x M12x90 (10.9)
- 2x M12
- 2x M6x20 (10.9)
- 2x M6



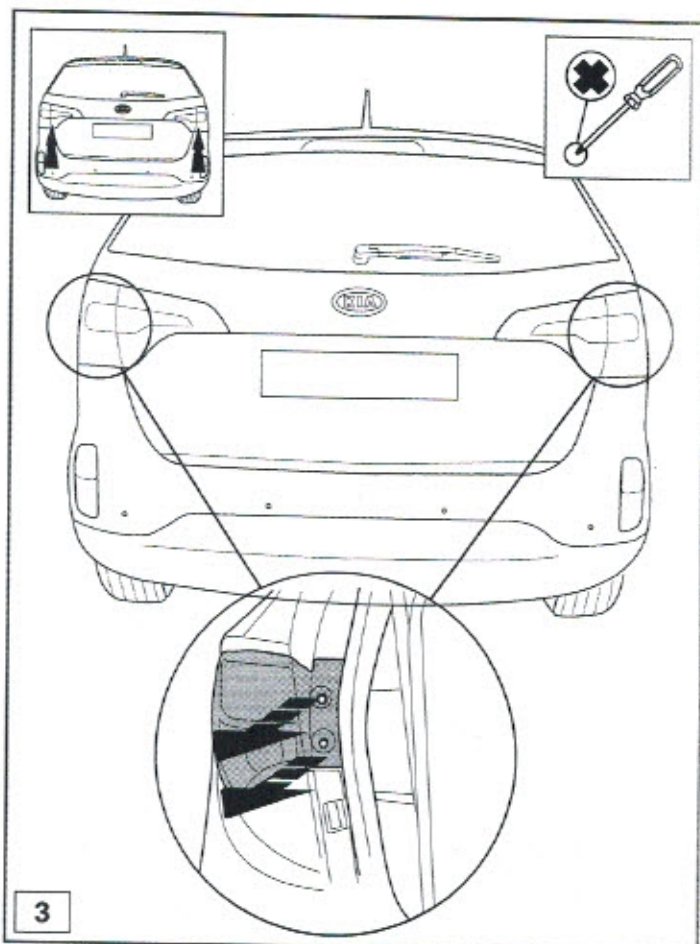
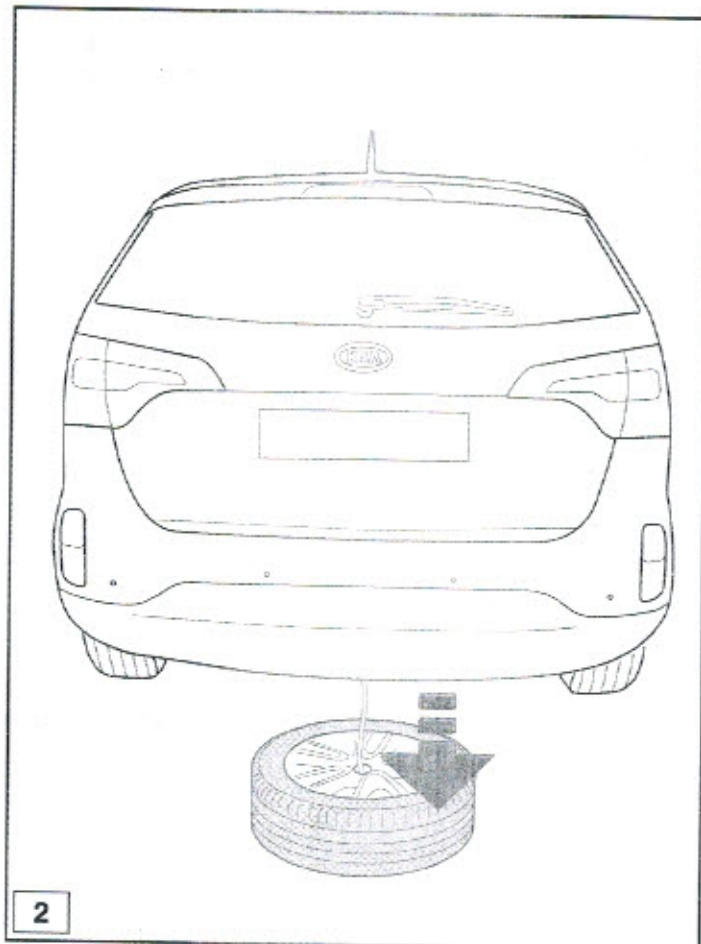

© 564472/01-11-2012/7

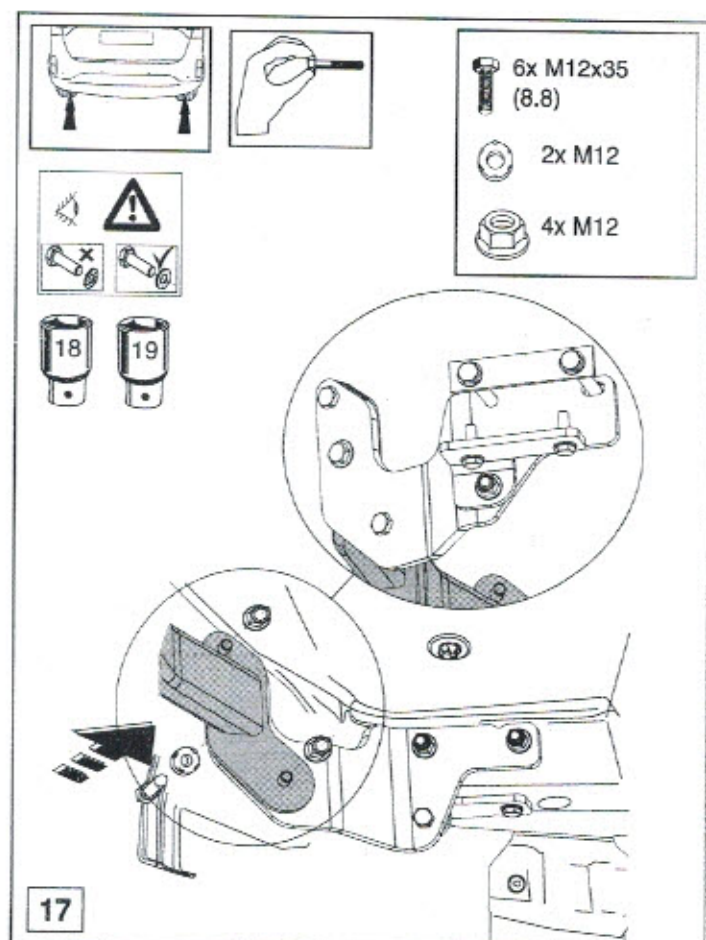
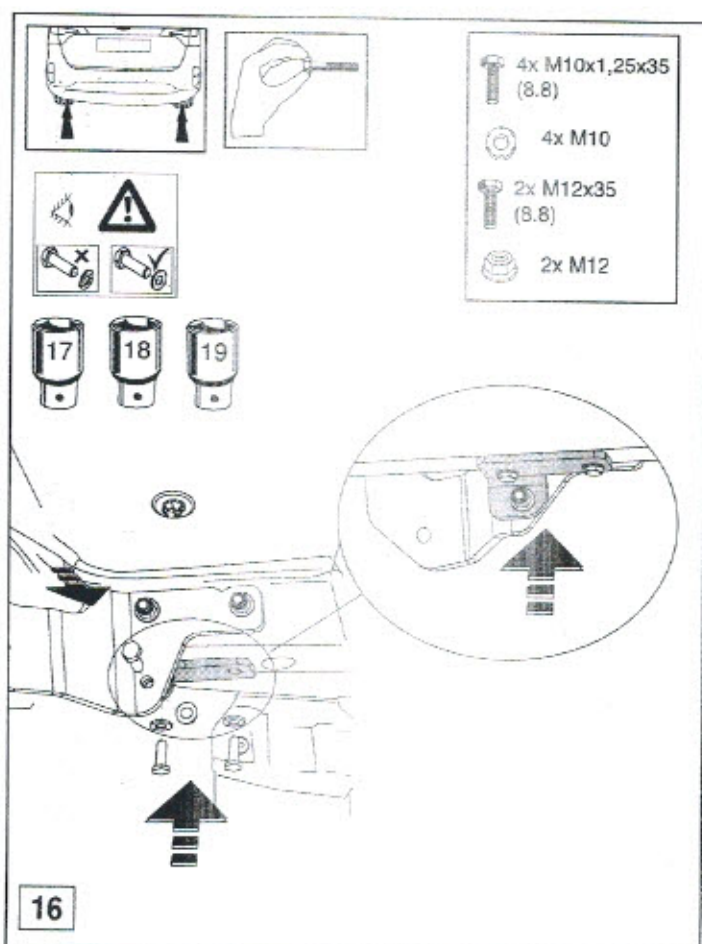

© 564472/01-11-2012/16

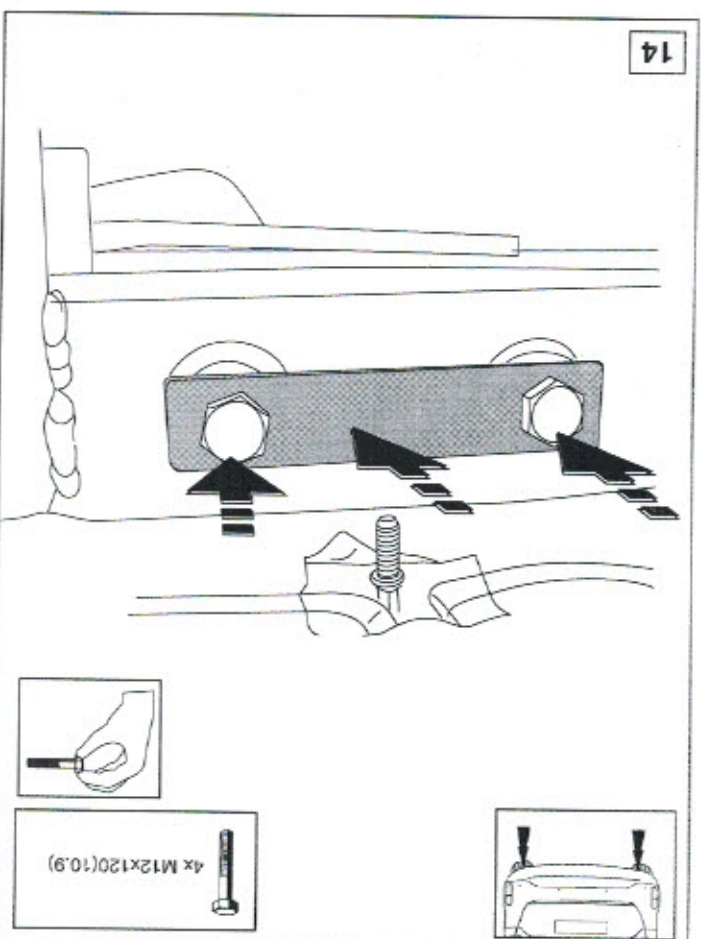
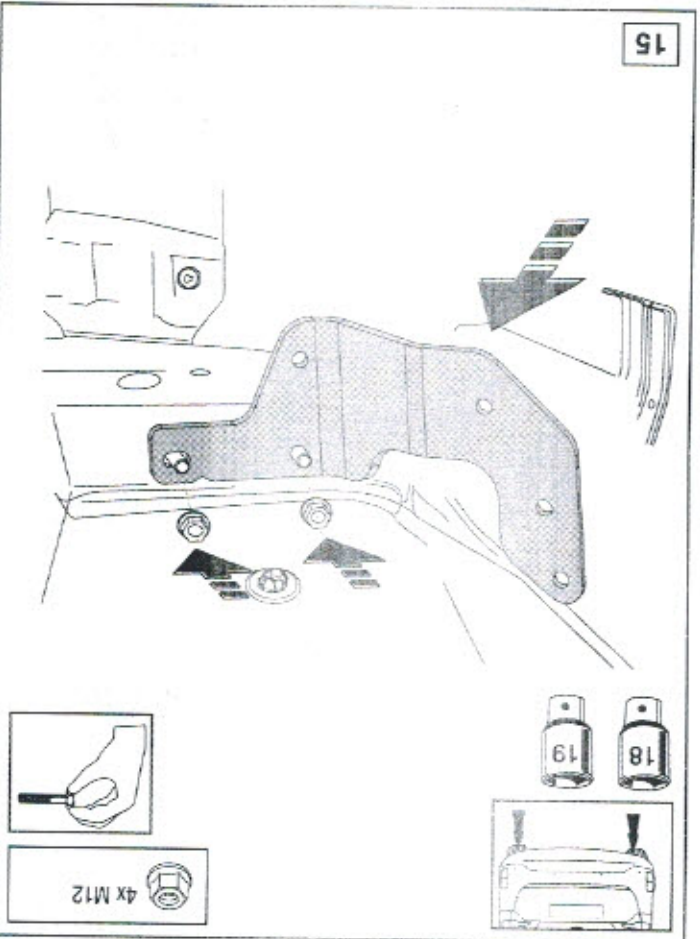
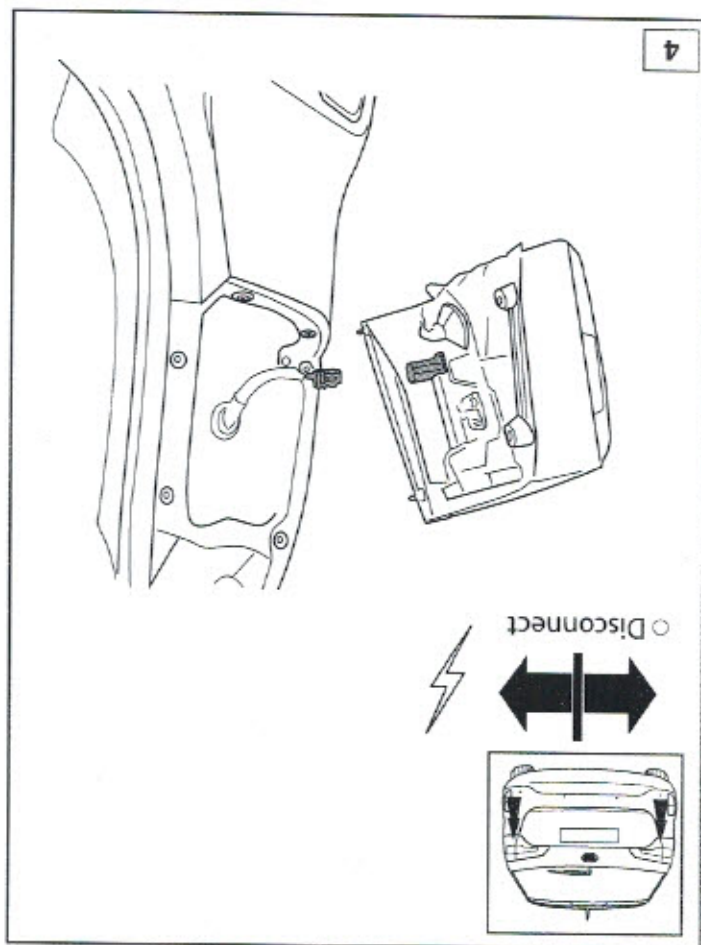
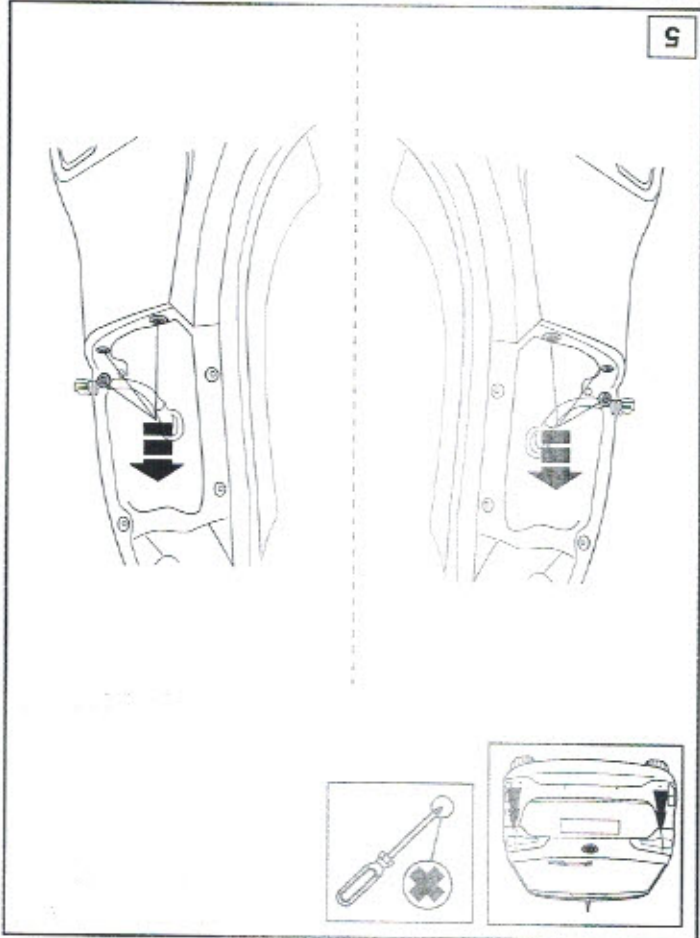

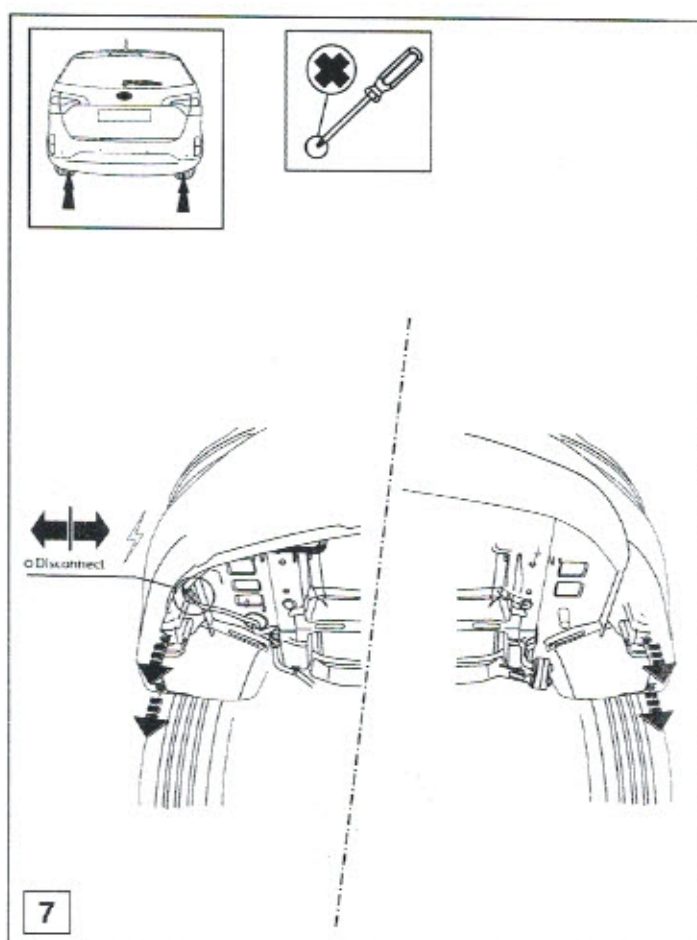
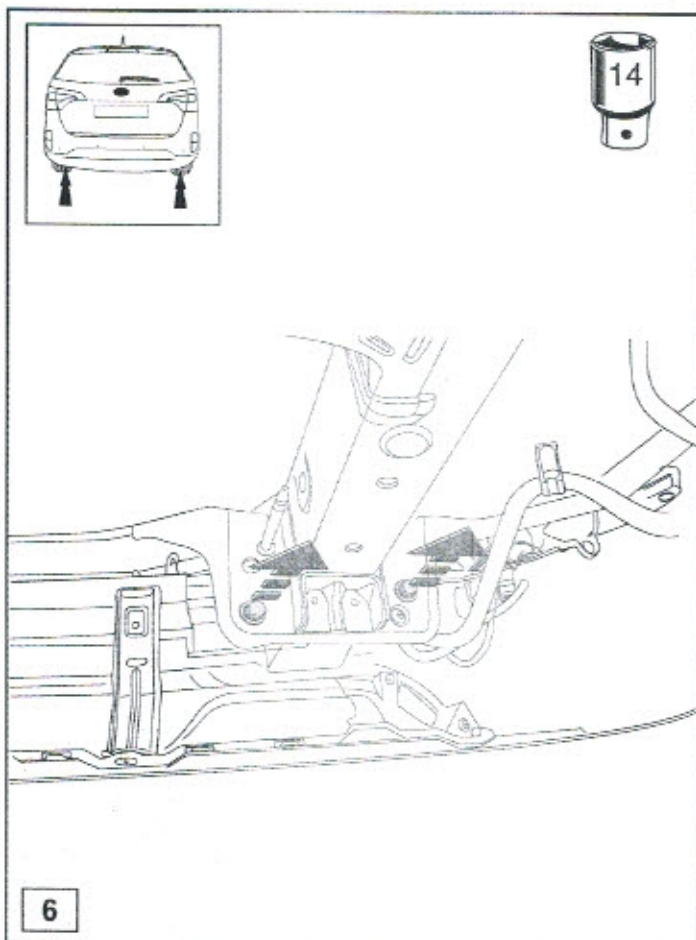

© 564472/01-11-2012/9

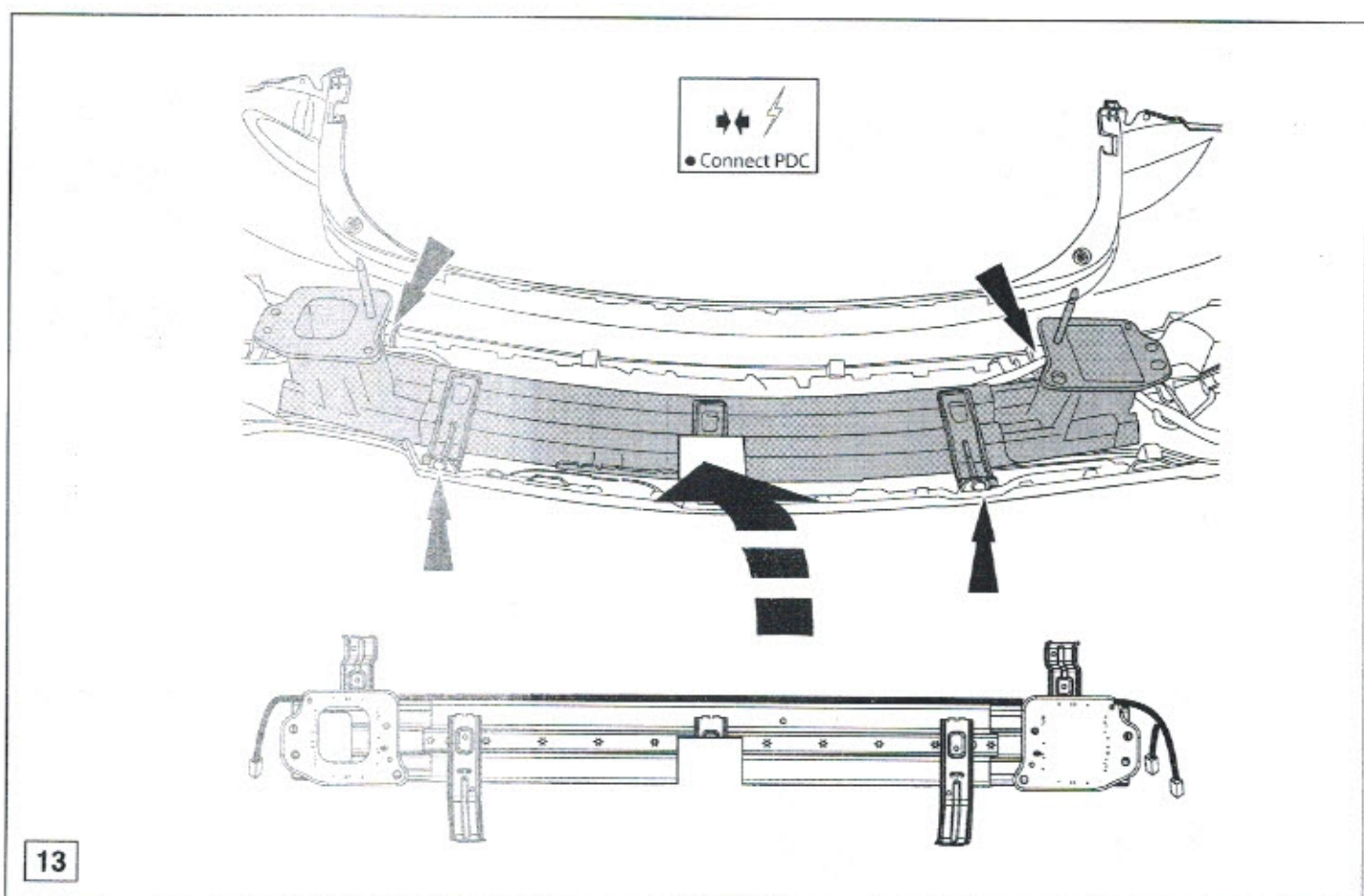

© 564472/01-11-2012/14

6

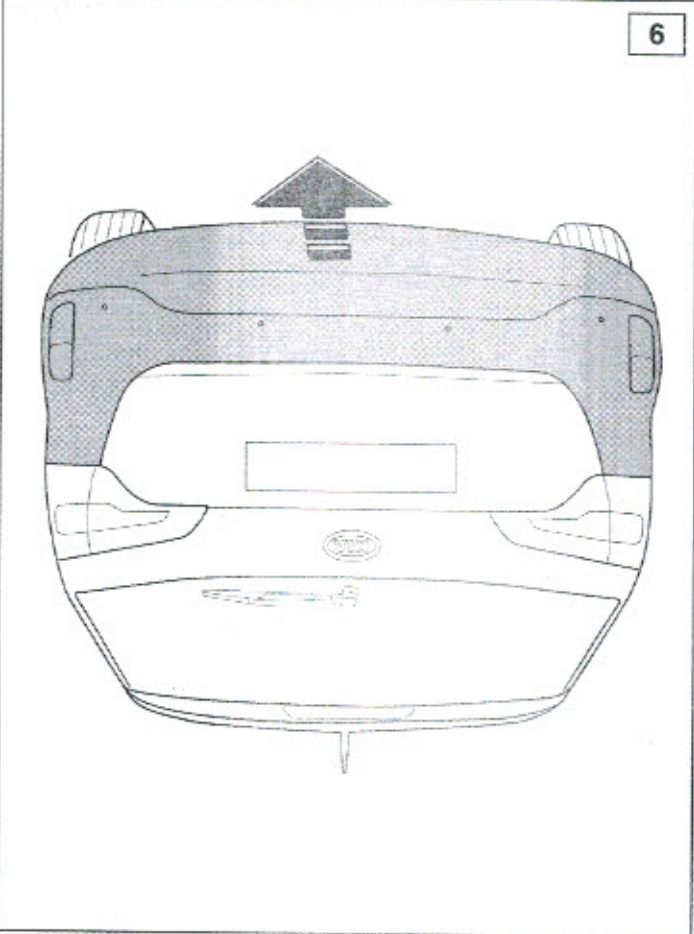

8

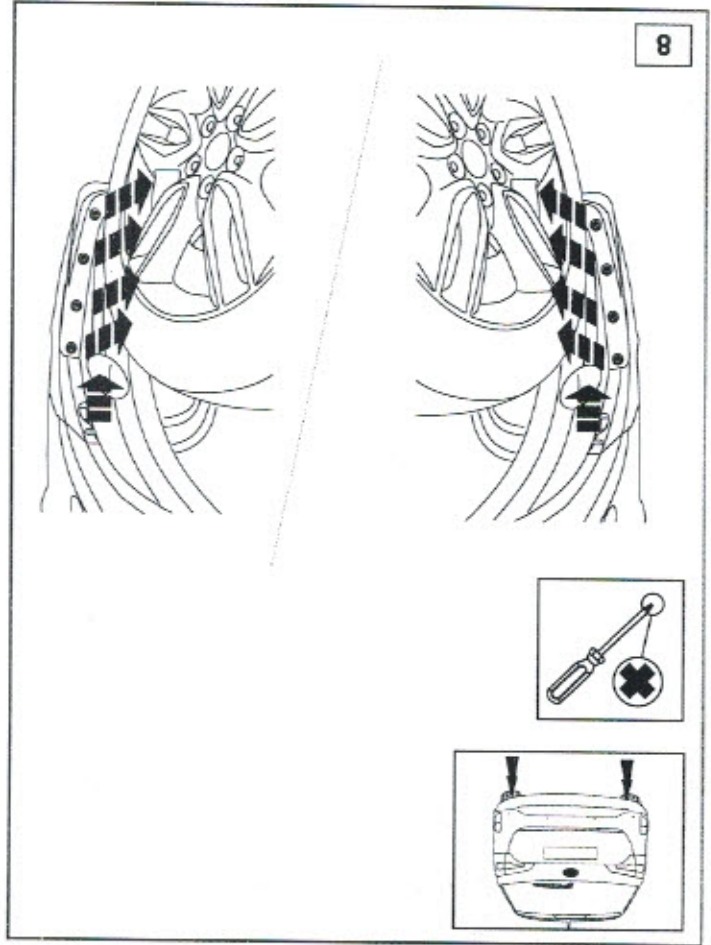

12

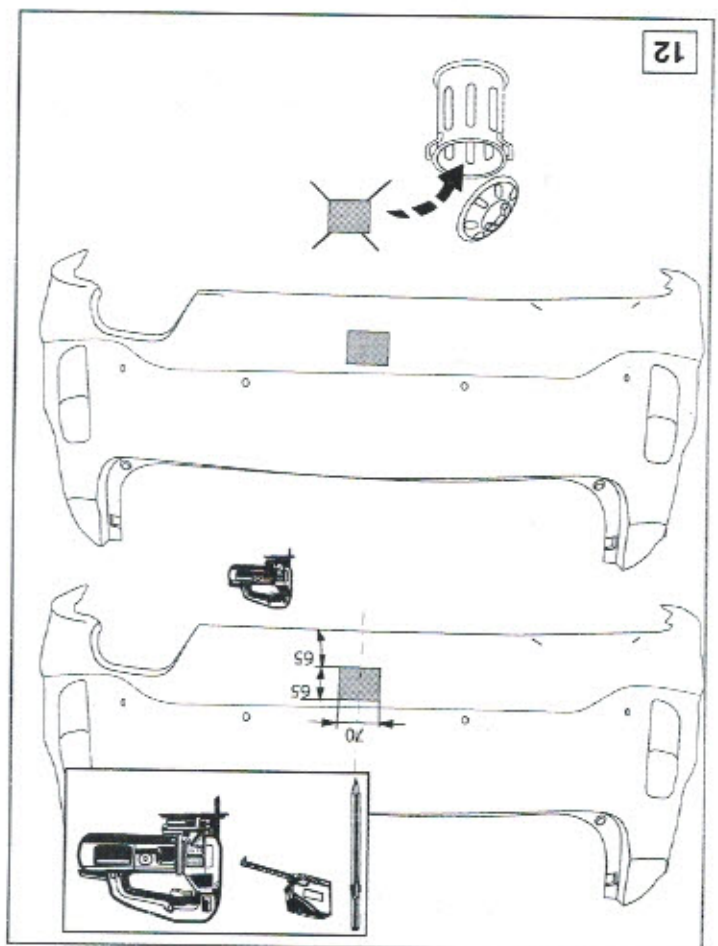

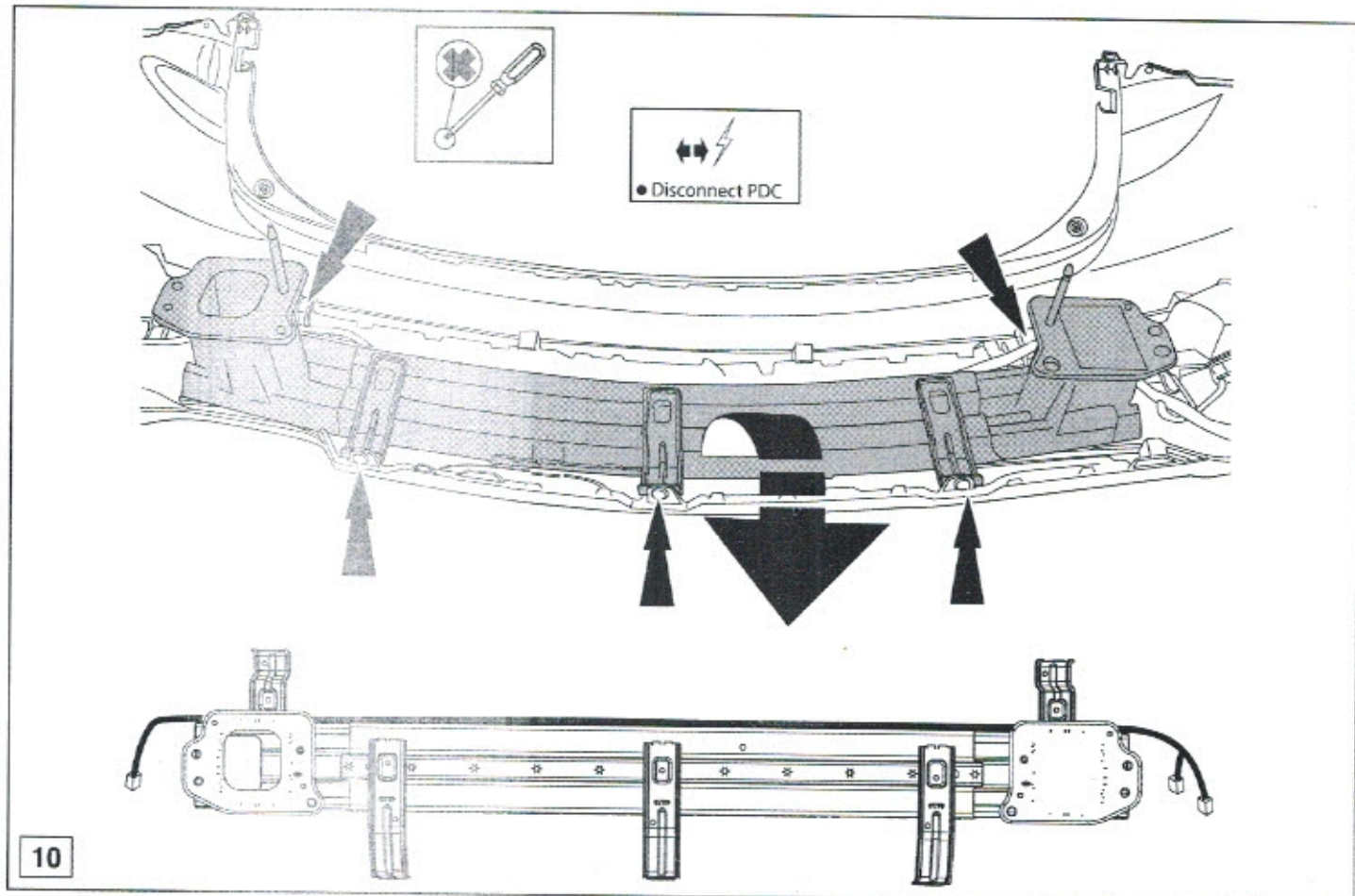

© 564472/01-11-2012/11

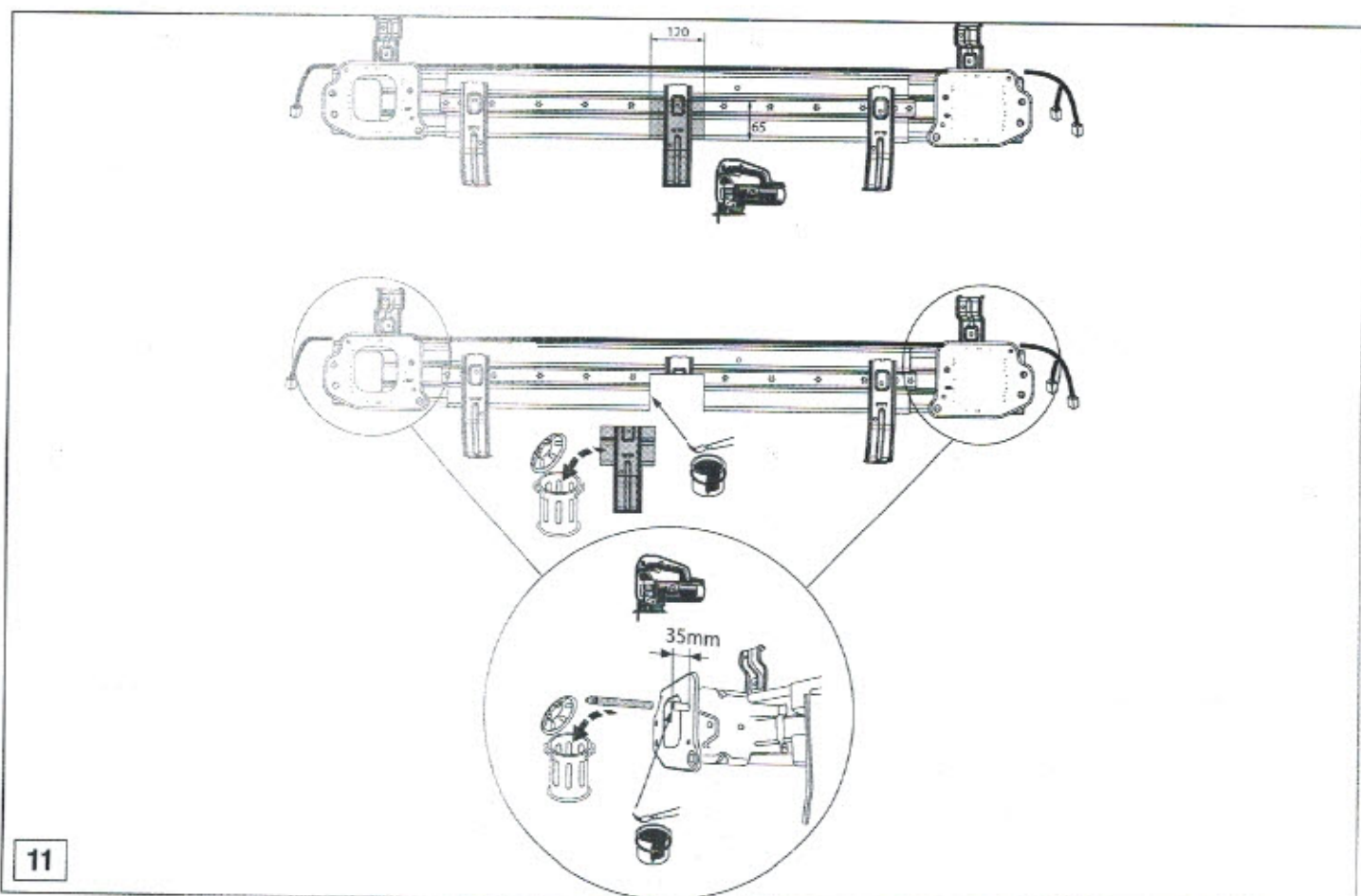

© 564472/01-11-2012/12